

## LAWS OF MOTION

## 5.1 ▽ FORCE

1. Define the term force. State the various effects a force can produce.

**Force.** Force may be defined as an agency (a push or a pull) which changes or tends to change the state of rest or of uniform motion or the direction of motion of a body.

**Effects produced by a force.** A force applied on an object can produce three types of changes :

1. Force can change speed of an object, making it to move slower or faster. For example, a horse by exerting a force on a cart, pulls it from rest and subsequently exerting a larger force, the horse makes the cart move with a larger speed. Similarly, a force exerted by the brakes slows or stops a moving train.

2. Force can change the direction of motion of an object. For example, the force exerted on the steering wheel of a car changes the direction of motion.

3. Force can change the shape of an object. For example, if we hold a rubber ball between our palms and push the two palms against each other, the ball no longer remains round but gets oblong.



## For Your Knowledge

- ▲ Force is a polar vector as it has a point of application.
- ▲ Forces can be classified as positive and negative. A positive force represents repulsion (e.g., between two like charges) and a negative force represents attraction (e.g., between two unlike charges).

## 5.2 ▽ ARISTOTLE'S FALLACY

2. What were the views of Greek philosopher Aristotle as regard to maintain the state of uniform motion of objects ?

**Aristotelian law of motion.** The Greek philosopher Aristotle (384-329 B.C.) asserted that the natural state of a body is the state of rest. Every body in motion tends to slow down and comes to rest. An external force is necessary to maintain its motion. For example, a cart on a road has to be constantly pushed to keep it in motion. A single push will not take it far. From such observations Aristotle concluded the following law :

According to **Aristotelian law of motion**, an external force is necessary to keep a body moving with uniform velocity.

However, Aristotle's views were proved wrong by Galileo Galleio (1564-1642) about two thousand years later on. It was observed that external forces were necessary to counter the opposing forces of friction to keep bodies in uniform motion. If there were no friction, no external force would be needed to maintain the state of uniform motion of a body.

## 5.3 ▽ THE LAW OF INERTIA

3. Describe Galileo's experiments concerning motion of objects on inclined planes. Hence state the law of inertia.

**Galileo's experiments on the motion of objects.** It was Galileo who first asserted that objects move with constant speed when no external forces act on them. He

arrived at this revolutionary conclusion on the basis of following simple experiments :

(a) **Galileo's experiments with single inclined plane.** Galileo first studied the motion of objects on an inclined plane, as shown in Fig. 5.1.

- Galileo observed that when an object moves down an inclined plane, its speed increases.
- When the object is moved up the inclined plane, its speed decreases.
- From the above two observations, Galileo argued that when the plane slopes neither upward nor downwards, there should be neither acceleration nor retardation.

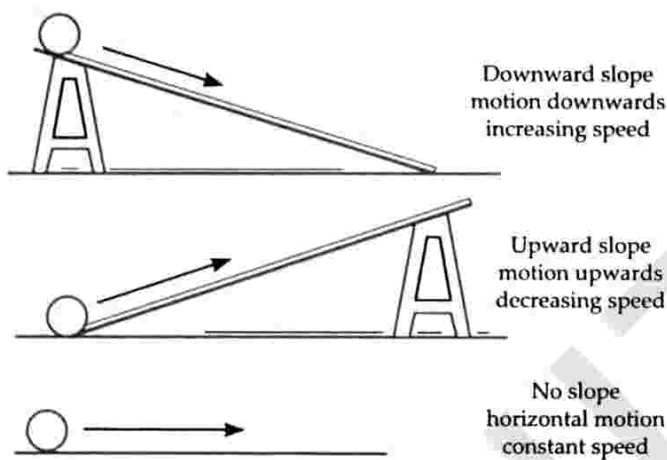
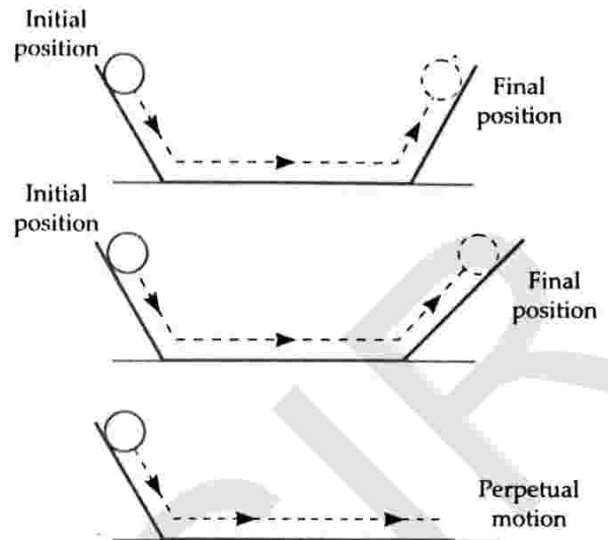

**Fig. 5.1** Galileo's observations of motion on a single inclined plane.

Galileo, therefore, concluded that *on a horizontal plane an object should move with a constant velocity in a straight line path.*

(b) **Galileo's experiments on two inclined planes combined together.** Galileo noted that in the case of an oscillating pendulum, the bob always reaches the same height on either side of the mean position. From this observation, Galileo thought of an imaginary experiment. In this experiment, two inclined planes are arranged facing each other, as shown in Fig. 5.2(a).

- When an object rolls down one of the inclined planes, it climbs up the other. It almost reaches the same height but not completely because of the presence of friction. If the friction were absent, the object must have reached the same height as the initial height, as shown in Fig. 5.2(a).
- When the slope of the upward inclined plane is decreased, the object has to travel a longer distance to reach the maximum height, as shown in Fig. 5.2(b). The more we decrease the slope of the upward inclined plane, the longer would be the distance that the object is needed to travel to reach the same height.



**Fig. 5.2** Galileo's observations of motion on a double inclined plane.

- From the above two observations, Galileo argued that if the second plane is made horizontal [Fig. 5.2(c)], the object will have to travel an infinite distance to reach the same height. This is possible only if the object moves forever with uniform velocity on the horizontal surface.

From the above series of experiments, Galileo formulated the following **law of inertia** :

*A body moving with a certain speed along a straight path will continue to move with same speed along the same straight path in the absence of external forces.*

## 5.4 ▽ INERTIA AND ITS DIFFERENT TYPES

4. Define the term inertia. What are different types of inertia ? Give one example of each type.

**Inertia.** The inherent property of a material body by virtue of which it cannot change, by itself, its state of rest or of uniform motion in a straight line is called inertia.

The term *inertia* means resistance to change. This term was first used by Galileo.

### Different types of inertia :

(i) **Inertia of rest.** The tendency of a body to remain in its position of rest is called inertia of rest.

**Example.** A person standing in a bus falls backward when the bus suddenly starts moving forward. When the bus moves, the lower part of his body begins to move along with the bus while the upper part of his body continues to remain at rest due to inertia. That is why, a person falls backward when the bus starts.

(ii) **Inertia of motion.** The tendency of a body to remain in its state of uniform motion in a straight line is called inertia of motion.

**Example.** When a moving bus suddenly stops, a person sitting in it falls forward. As the bus stops, the lower part of his body comes to rest along with the bus while the upper part of his body continues to remain in motion due to inertia and falls forward.

(iii) **Inertia of direction.** The inability of a body to change by itself its direction of motion is called inertia of direction.

**Example.** When a bus takes a sharp turn, a person sitting in the bus experiences a force acting away from the centre of the curved path due to his tendency to move in the original direction. He has to hold on to a support to prevent himself from swaying away in the turning bus.

**5. How is the inertia of a body measured ?**

**Mass as the measure of inertia.** Mass of a body is the measure of its inertia. If a body has more mass, it has more inertia i.e., it is more difficult to change its state of rest or of uniform motion. For example, if we kick a football, it flies a long way. If we kick a stone of the same size, it hardly moves. The stone opposes the change in its motion better than the football because of its more mass. Thus stone has more inertia than football.

**5.5 LINEAR MOMENTUM**

6. Taking suitable examples, develop the concept of momentum.

**Concept of Momentum.** When a small piece of stone is dropped from a small height on a glass pane placed on a table, it does not break the glass pane. But when a heavy stone is dropped from the same height, the glass pane breaks. Here the small and the heavy stones have the same velocity when they fall on the glass pane.

On the other hand, a greater effort is required to stop a bullet fired from the gun than to stop a bullet of the same mass when just thrown by the hand. In the former case, the bullet has large velocity.

The above examples show that the effect of motion of a body depends both on its mass and velocity. The product of mass and velocity of a body is called its momentum.

7. Define momentum. Is it a scalar or a vector quantity? Give its units and dimensions.

**Momentum.** Momentum of a body is the quantity of motion possessed by the body. It is equal to the product of mass and velocity of the body.

$$\text{Momentum} = \text{Mass} \times \text{velocity}$$

$$\vec{p} = m \vec{v}$$

Momentum is a vector quantity because the velocity  $\vec{v}$  is a vector and mass  $m$  is a scalar. Its direction is same

as the direction of the velocity of the body. Its magnitude is given by

$$p = mv$$

$$\text{SI unit of momentum} = \text{kg ms}^{-1}$$

$$\text{CGS unit of momentum} = \text{g cm s}^{-1}$$

The dimensional formula of momentum is  $[\text{MLT}^{-1}]$ .

8. Discuss the variation of momentum when two bodies of equal/different masses have different/equal momenta. Show the each situation graphically.

**Case 1.** Consider two objects, each of mass  $m$ . Suppose the two objects are moving with velocities  $v_1$  and  $v_2$  with  $v_1 > v_2$ . Then

$$p_1 = mv_1 \quad \text{and} \quad p_2 = mv_2$$

$$\therefore \frac{p_1}{p_2} = \frac{mv_1}{mv_2} = \frac{v_1}{v_2}$$

As  $v_1 > v_2$ , so  $p_1 > p_2$

Thus, the linear momenta of bodies having equal masses are proportional to their velocities. This is shown graphically in Fig. 5.3(a).

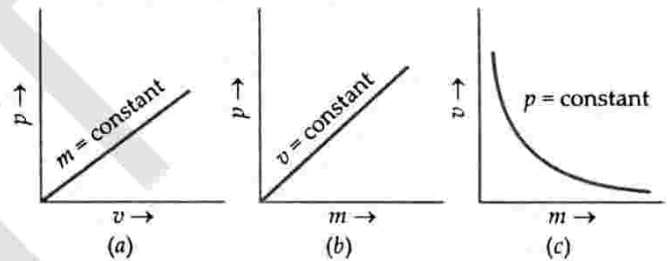

**Fig. 5.3**

**Case 2.** Consider a heavier object of mass  $m_1$ , and a lighter object of mass  $m_2$ . Suppose both the objects are moving with same velocity  $v$ . Then

$$p_1 = m_1v \quad \text{and} \quad p_2 = m_2v$$

$$\therefore \frac{p_1}{p_2} = \frac{m_1}{m_2}$$

As  $m_1 > m_2$ , so  $p_1 > p_2$

Thus, the linear momenta of bodies having equal velocities are proportional to their masses. This is shown graphically in Fig. 5.3(b).

**Case 3.** Consider two objects having equal linear momenta. Thus

$$p_1 = p_2 \quad \text{or} \quad m_1v_1 = m_2v_2$$

$$\text{or} \quad \frac{v_2}{v_1} = \frac{m_1}{m_2}$$

As  $m_1 > m_2$ , so  $v_1 < v_2$ .

Thus, the velocities of bodies having equal linear momenta are inversely proportional to their masses. i.e., when two objects have equal linear momentum, the lighter object will move faster than the heavier one.

## 5.6 NEWTON'S LAWS OF MOTION

### 9. State the three Newton's laws of motion.

**Newton's laws of motion.** Sir Isaac Newton (1642 – 1727) made a systematic study of motion and extended the ideas of Galileo. He arrived at three laws of motion which are called Newton's laws of motion. These laws are as follows :

**First law.** Every body continues in its state of rest or of uniform motion in a straight line unless it is compelled by some external force to change that state.

**Second law.** The rate of change of linear momentum of a body is directly proportional to the applied force and the change takes place in the direction of the applied force.

**Third law.** To every action, there is always an equal and opposite reaction.

## 5.7 DISCUSSION OF THE FIRST LAW OF MOTION

### 10. State and explain Newton's first law of motion.

**Newton's first law of motion.** This law states that every body continues in its state of rest or of uniform motion in a straight line unless it is compelled by some external force to change that state. This law consists of three parts :

(i) **First part** says that a body at rest continues in its state of rest. An external force has to be applied on it to make it move. A chair lying on the floor will continue to remain there unless we displace it.

(ii) **Second part** says that a body in motion continues moving in a straight path with a uniform speed. This part seems to be contrary to our everyday experience. A rolling ball comes to rest on a rough ground. This is because of force of friction. The ball moves through a larger distance on a smooth floor. If the friction were zero, the ball would continue its motion forever. This part also indicates that to increase or decrease the speed of a body moving in a straight line, a force has to be applied on it in the direction of motion or opposite to the direction of motion.

(iii) **Third part** says that a body moving with a uniform speed in a straight line cannot change itself its direction of motion. To change its direction of motion, a force has to be applied normal to this direction of motion. Consider the motion of the moon around the earth. The direction of motion of the moon continuously changes. The force needed to change the direction is provided by the gravitational attraction of the earth on the moon.

### 11. How does Newton's first law of motion lead to the definition of force ?

**Newton's first law defines force.** According to Newton's first law of motion, a body at rest or in uniform motion will remain at rest or in uniform motion unless an external force acts upon it. This

shows that force is an agency which changes the state of rest or uniform motion. But sometimes a force applied on a body is not able to change its state of rest or of uniform motion. So it is better to define *force as an external agency which changes or tends to the state of rest or of uniform motion in a straight line.* Hence first law of motion gives a qualitative definition of force.

### 12. Why is Newton's first law of motion also called law of inertia ?

**Newton's first law defines inertia.** According to Newton's first law of motion, every body continues in its state of rest or uniform motion unless an external force acts upon it. This shows that a body, by itself, cannot change its state of rest or uniform motion. This inability of a body to change its state of rest or of uniform motion along a straight line is called *inertia of the body.* Thus first law defines inertia and hence it is rightly called the law of inertia.

### 13. Give some examples from daily life that illustrate the law of inertia.

#### Illustrations of Newton's first law of motion :

##### A. Based on inertia of rest.

(i) **When a horse suddenly starts running, the rider falls backward.** This is because the lower part of the rider, which is in contact with the horse, comes into motion while his upper part tends to remain at rest due to inertia.

(ii) **Dust is removed from a hanging carpet by beating it with a stick.** As the carpet is beaten, it suddenly moves forward while the dust particles tend to remain at rest due to inertia of rest and so fall off.

(iii) **When we shake the branch of a tree, its fruits and dry leaves fall down.** On shaking, the branch comes into motion while the dry fruits and leaves tend to remain at rest (inertia of rest) and so get separated.

(iv) **Coin falls into the tumbler when the card is given a sudden jerk.** Place a five rupees coin on a playing card covering a glass tumbler. Give a sudden jerk to the card, the card flies off and the coin drops into the tumbler. This is because the coin tends to remain at rest due to inertia.

(v) As shown in Fig. 5.4, suspend a body *M* of mass about 2 kg from a rigid support by means of thread *A* and pull it down by another thread *B*. When the force *F* is applied as a

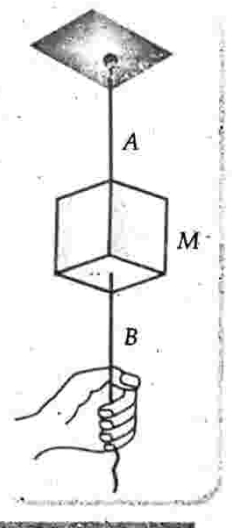

Fig. 5.4

steady pull, the thread breaks at  $A$  but when it is applied as a sudden jerk, the thread breaks at  $B$ . In the first case the force gets sufficient time to reach the position  $A$ . In the second case, the upper portion of the system is not able to share the force in short time and the block tends to remain at rest.

### B. Based on inertia of motion.

(i) *When a horse running fast suddenly stops, the rider is thrown forward* if he is not firmly seated. This is because the lower part of the rider's body, which is in contact with the horse, comes to rest while the upper part of his body tends to keep moving due to inertia.

(ii) *A person getting out of a moving bus or train falls in the forward direction.* As the man jumps out of a moving bus, his feet suddenly come to rest on touching the ground while the upper part of his body continues to move forward. That is why he falls with his head forward. In order to save himself from falling down, he should run in the forward direction through some distance.

(iii) *An athlete runs for a certain distance before taking a long jump.* The inertia of motion gained by him at the time of jumping adds to his muscular effort and helps him in taking a longer jump.

(iv) A fireman in a railway engine quickly moves his coal shovel near the furnace and then suddenly stops it. The shovel comes to rest but the coal continues moving due to inertia and falls into the furnace.

(v) *A ball thrown upward in a moving train comes back into the thrower's hands.* The ball acquires the horizontal velocity of the train and maintains it (inertia of motion) during its upward and downward motion. In this period the ball covers the same horizontal distance as the train, so it comes back into the thrower's hands.

### C. Based on inertia of direction.

(i) Consider a stone being rotated in a circle at the end of a string. The velocity of the stone at any instant is along the tangent to the circle. When the string is released, the centripetal force whirling the stone vanishes. Due to directional inertia, the stone flies off tangentially.

(ii) During the sharpening of a knife, *the sparks coming from the grind stone fly off tangentially* to the rim of the rotating stone. This is due to the inertia of direction.

(iii) *When a vehicle moves, the mud sticking to its wheels flies off tangentially.* This is due to inertia of direction. In order that the flying mud does not spoil the clothes of the passerby, the wheels are provided with mudguards.

(iv) *When a dog chases a hare, the hare runs along a zig-zag path.* It becomes difficult for the dog to catch the hare. This is because the dog has more mass and hence has more inertia of direction than that of hare.

## 5.8 DISCUSSION OF NEWTON'S SECOND LAW OF MOTION

14. Describe the important observation which led Newton to postulate his second law of motion.

**Clue to the second law of motion.** Suppose a fixed force is applied on two bodies of different masses for the same duration. The lighter body gains a higher speed than the heavier one. However, the change in momentum in both cases is found to be the same. This shows that the *same force for the same time causes the same change in momentum for bodies of different masses.* This fact was first recognised by Newton who expressed it as his second law of motion.

15. State and explain Newton's second law of motion.

**Newton's second law of motion.** It states that the rate of change of momentum of a body is directly proportional to the external force applied on the body and the change takes place in the direction of the applied force. This law can be divided into two parts :

(i) *The rate of change of momentum is directly proportional to the applied force.* The larger the force acting on a body, greater is the change in its momentum. Since change in momentum is equal to the product of mass and the change in velocity and the mass of the body remains constant, so the rate of change of momentum is directly proportional to the rate of change of velocity i.e., acceleration. Hence force  $F$  is proportional to both mass ( $m$ ) and acceleration ( $a$ ).

$$F \propto ma$$

(ii) *The change of momentum occurs in the direction of the force.* If a body is at rest, a force will set it in motion. If a body is moving with a certain velocity, a force will increase or decrease this velocity accordingly as the force acts in its same or opposite direction.

16. Explain how does Newton's second law of motion give a quantitative definition of force:

**Measurement of force from Newton's second law of motion.** If a body of mass  $m$  is moving with velocity  $\vec{v}$ , then its linear momentum is

$$\vec{p} = m\vec{v}$$

Differentiating both sides w.r.t. time  $t$ , we get

$$\frac{d\vec{p}}{dt} = \frac{d}{dt}(m\vec{v}) = m \frac{d\vec{v}}{dt} = m\vec{a}$$

where  $\vec{a}$  is the acceleration produced in the body.

According to Newton's second law,

Applied force  $\propto$  Rate of change of momentum

$$\text{or } \vec{F} \propto \frac{d\vec{p}}{dt}$$

$$\text{or } F \propto m\vec{a}$$

$$\therefore \vec{F} = km\vec{a}$$

The units of  $m$ ,  $a$  and  $F$  are so chosen that the proportionality constant  $k = 1$ . Suppose  $m = 1$ ,  $a = 1$  and  $F = 1$ , then

$$1 = k \times 1 \times 1 \quad \text{or} \quad k = 1$$

$$\therefore \vec{F} = m\vec{a}$$

The above equation can be used to measure force.

In scalar form, Newton's second law can be expressed as

$$F = ma$$

$\therefore$  1 unit force = 1 unit mass  $\times$  1 unit acceleration

Hence a unit force may be defined as the force which produces unit acceleration in a body of unit mass.

**17.** Is force a scalar or vector quantity? Write its dimensional formula.

As force is the product of mass  $m$  (scalar) and acceleration  $\vec{a}$  (vector), so it is a vector quantity. The direction of force  $\vec{F}$  is same as that of acceleration  $\vec{a}$ .

Dimensional formula of force is  $[MLT^{-2}]$ .

**18.** Name and define the various absolute and gravitational units of force.

**Absolute units of force.** An absolute unit of force is that force which produces a unit acceleration in a body of unit mass.

(i) In SI, the absolute unit of force is **newton (N)**. One newton is defined as that much force which produces an acceleration of  $1 \text{ ms}^{-2}$  in a body of mass 1 kg.

$$1 \text{ N} = 1 \text{ kg} \times 1 \text{ ms}^{-2} = 1 \text{ kg ms}^{-2}$$

(ii) In CGS system, the absolute unit of force is **dyne (dyn)**. One dyne is that much force which produces an acceleration of  $1 \text{ cm s}^{-2}$  in a body of mass 1 gram.

$$1 \text{ dyne} = 1 \text{ g} \times 1 \text{ cm s}^{-2} = 1 \text{ g cm s}^{-2}$$

**Gravitational units of force.** A gravitational unit of force is that force which produces an acceleration equal to 'g' (acceleration due to gravity) in a body of unit mass. It may also be defined as the weight of a body of unit mass.

(i) In SI, the gravitational unit of force is **kilogram weight (kg wt) or kilogram force (kg f)**. It is defined as that much force which produces an acceleration of  $9.80 \text{ ms}^{-2}$  in a body of mass 1 kg.

$$1 \text{ kg wt} = 1 \text{ kg f} = 9.8 \text{ N}$$

(ii) In CGS system, the gravitational unit of force is **gram weight (g wt) or gram force (g f)**. It is defined as that force which produces an acceleration of  $980 \text{ cm s}^{-2}$  in a body of mass 1 gram,

$$1 \text{ g wt} = 1 \text{ g f} = 980 \text{ dyne}$$

**19.** Find the number of dynes in one newton.

**Relation between newton and dyne.**

$$1 \text{ N} = 1 \text{ kg} \times 1 \text{ ms}^{-2} = 1000 \text{ g} \times 100 \text{ cm s}^{-2} \\ = 10^5 \text{ g cm s}^{-2}$$

$$\text{or } 1 \text{ N} = 10^5 \text{ dyne}$$

**20.** How do the gravitational units of force differ from the absolute units of force?

The absolute units of force remain the same throughout the universe. But the gravitational units of force vary from place to place because they depend on the value of  $g$  which takes different values at different places.

#### For Your Knowledge

- ▲ A gravitational unit is 'g' times the corresponding absolute unit.
- ▲ A gravitational unit of force is used to express the weight of a body. For example, the weight of a body of mass 10 kg is 10 kg wt or 10 kg f. For this reason, the gravitational units are also called *practical units*.

**21.** Express Newton's second law of motion in component form. Give its significance.

**Newton's second law in component form.** In terms of their rectangular components, the force, momentum and acceleration vectors can be expressed as

$$\vec{F} = F_x \hat{i} + F_y \hat{j} + F_z \hat{k}$$

$$\vec{p} = p_x \hat{i} + p_y \hat{j} + p_z \hat{k}$$

$$\text{and } \vec{a} = a_x \hat{i} + a_y \hat{j} + a_z \hat{k}$$

The vector form of Newton's second law is

$$\vec{F} = \frac{d\vec{p}}{dt} = m\vec{a}$$

$$\therefore F_x \hat{i} + F_y \hat{j} + F_z \hat{k} = \frac{d}{dt} (p_x \hat{i} + p_y \hat{j} + p_z \hat{k}) \\ = m(a_x \hat{i} + a_y \hat{j} + a_z \hat{k})$$

Equating the components along the three coordinate axes, we get

$$F_x = \frac{dp_x}{dt} = ma_x$$

$$F_y = \frac{dp_y}{dt} = ma_y$$

$$F_z = \frac{dp_z}{dt} = ma_z$$

The above three equations express Newton's second law in component form.

**Significance of component form.** The component form of Newton's second law indicates that if the applied force makes some angle with the velocity of the body, it changes the component of velocity along the direction of the force. The component of velocity normal to the force remains unchanged. For example, in the motion of a projectile under the vertical gravitational force, the horizontal component of velocity remains unchanged.

**22. Give four important implications of Newton's second law of motion.**

**Some important implications of Newton's second law :**

(i) The second of motion is a vector law expressed as

$$\vec{F} = m\vec{a}$$

(ii) In the second law, if  $\vec{F} = 0$ , then  $\vec{a} = 0$ . This indicates that a body moves with a uniform velocity in the absence of any external force. Thus second law is consistent with the first law.

(iii) The second law is strictly applicable to a point particle, but is also applicable to a body or a system of particles, provided  $\vec{F}$  is the total external force on the system and  $\vec{a}$  is the acceleration of the system as a whole.

(iv) Second law of motion is a local relation. This means  $\vec{F}$  at a space point at a certain instant determines  $\vec{a}$  at the same point and the same instant.

**23. What does it mean that Newton's second law is a local relation? Explain it with an example.**

**Second law of motion is a local relation.** The acceleration  $\vec{a}$  at any point (location of the particle) at any instant is determined by the force  $\vec{F}$  at the same point at the same instant. That is, acceleration is determined here and now by the force here and now, not by the earlier history of motion of the particle. For example, the moment a stone is released out of an accelerated train, there is no horizontal force or

acceleration on the stone, if air resistance is neglected. The stone has only the vertical force of gravity. It carries no memory of its acceleration with the train a moment ago.

### 5.9 CONSEQUENCES OF NEWTON'S SECOND LAW

**24. How does Newton's second law of motion lead to the concept of inertial mass?**

**Concept of inertial mass.** Suppose a force  $F$  acting independently on two masses  $m_1$  and  $m_2$  produces accelerations  $a_1$  and  $a_2$  in them. By using Newton's second law, we get

$$F = m_1 a_1 = m_2 a_2 \quad \text{or} \quad \frac{a_1}{a_2} = \frac{m_2}{m_1}$$

If  $m_2 < m_1$ , then  $a_2 > a_1$ , i.e., a given force produces a larger acceleration in a lighter mass than that in a heavier mass. Thus *the mass of a body gives a measure of the resistance or the opposition to a given force that tends to change its velocity.* That is why,  $m = F/a$  is called the **inertial mass** of the body.

**25. State the three different ways in which accelerated motion of a body can occur under an external force.**

**The accelerated motion of a body is always due to an external force.** It can occur in the following ways :

- (i) *Due to the change in the speed.* This happens when the force acts on the body along the direction of motion or opposite to the direction of motion.
- (ii) *Due to the change in the direction of motion.* This happens when the force acts perpendicular to the direction of motion. Such a force produces circular motion.
- (iii) *Due to the change in both speed and direction of motion.* This happens when the force is inclined at some angle with the direction of motion. The tangential component changes speed while the transverse component changes direction.

**26. Briefly explain how an unknown force can be measured with the help of a coiled spring.**

**Measurement of unknown force.** When a spring is stretched by a constant force, the increase in the length of the spring is proportional to the applied force. This fact can be used to measure an unknown force. As shown in Fig. 5.5, consider a spring attached to a block resting on a frictionless surface. When the spring is

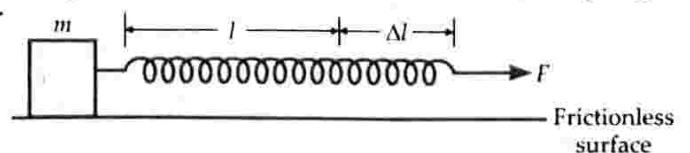

**Fig. 5.5** Force due to a spring.

pulled with a force  $F$ , the block acquires acceleration  $a$ . If the spring stretches by an amount  $\Delta l$ , then

$$F \propto \Delta l$$

If the mass of the block is 1 kg and the acceleration produced is  $1 \text{ ms}^{-2}$ , then the applied force would be 1 N. Suppose the extension in the spring is  $\Delta l_0$  in this case. Then

$$1 \text{ N} \propto \Delta l_0 \quad \therefore \frac{F}{1 \text{ N}} = \frac{\Delta l}{\Delta l_0} \quad \text{or} \quad F = \frac{\Delta l}{\Delta l_0} \text{ N}$$



### For Your Knowledge

- ▲ Force is not always in the direction of motion. It may be along  $\vec{v}$ , opposite to  $\vec{v}$ , normal to  $\vec{v}$  or may make some angle with  $\vec{v}$ .
- ▲ In every motion, force  $\vec{F}$  is parallel to acceleration  $\vec{a}$ .
- ▲ No force is required to move a body with a uniform velocity. In that case,  $a = 0$ , so  $F = ma = 0$ .
- ▲ Force can be measured from Newton's second law of motion.

$$F = ma = m \frac{\Delta v}{\Delta t}$$

By knowing mass  $m$  and change in velocity  $\Delta v$  in time  $\Delta t$ , the force  $F$  can be determined.

- ▲ The cause of every accelerated motion is an external force. Internal forces have no role to play.
- ▲ If  $\vec{v} = 0$  at an instant, i.e., if a body is momentarily at rest, it does not mean that force or acceleration are necessarily zero at that instant. For example, when a ball thrown up reaches its maximum height,  $\vec{v} = 0$  but the force continues to be its weight  $mg$  and acceleration equal to  $g$ .
- ▲ The straight line along which a force acts is called the line of action of the force.

### Examples based on Linear Momentum and Newton's Second Law of Motion

#### FORMULAE USED

1. Linear momentum,  $p = mv$
2. According to Newton's second law,  
Applied force = Rate of change of linear momentum  
or  $F = \frac{dp}{dt} = ma = m \left( \frac{v-u}{t} \right)$

#### UNITS USED

Velocities  $u$  and  $v$  are in  $\text{ms}^{-1}$ , time  $t$  in second, momentum  $p$  in  $\text{kgms}^{-1}$ , acceleration  $a$  in  $\text{ms}^{-2}$  and force  $F$  in newton (N).

#### CONVERSIONS USED

$1 \text{ N} = 10^5 \text{ dyne}$ ,  $1 \text{ kg wt} = 9.8 \text{ N}$ ,  $1 \text{ g wt} = 980 \text{ dyne}$

**EXAMPLE 1.** A car of mass 1000 kg is moving with a velocity of  $10 \text{ ms}^{-1}$  and is acted upon by a forward force of 1000 N due to engine and retarding force of 500 N due to friction. What will be its velocity after 10 seconds?

**Solution.** Here  $m = 1000 \text{ kg}$ ,  $u = 10 \text{ ms}^{-1}$ ,  $t = 10 \text{ s}$ ,  
 $u = ?$

Net forward force,

$$F = \text{Forward force} - \text{Retarding force} \\ = 1000 - 500 = 500 \text{ N}$$

Acceleration,

$$a = \frac{F}{m} = \frac{500}{1000} = \frac{1}{2} \text{ ms}^{-2}$$

$$\therefore v = u + at = 10 + \frac{1}{2} \times 10 = 15 \text{ ms}^{-1}$$

**EXAMPLE 2.** A bullet of mass 0.04 kg moving with a speed of  $90 \text{ ms}^{-1}$  enters a heavy wooden block and is stopped after a distance of 60 cm. What is the average resistive force exerted by the block on the bullet? [NCERT]

**Solution.** Here  $m = 0.04 \text{ kg}$ ,  $u = 90 \text{ ms}^{-1}$ ,  
 $v = 0$ ,  $s = 60 \text{ cm} = 0.60 \text{ m}$

$$\text{As } v^2 - u^2 = 2as$$

$$\therefore 0 - (90)^2 = 2a \times 0.60 \quad \text{or} \quad a = -6750 \text{ ms}^{-2}$$

i.e. Retardation =  $6750 \text{ ms}^{-2}$

$$\therefore \text{Retarding force} = \text{Mass} \times \text{retardation} \\ = 0.04 \times 6750 = 270 \text{ N}$$

**EXAMPLE 3.** A force of 72 dyne is inclined to the horizontal at an angle of  $60^\circ$ . Find the acceleration in a mass of 9 g, which moves in a horizontal direction.

**Solution.** Here  $m = 9 \text{ g}$ ,  $F = 72 \text{ dyne}$ ,  $\theta = 60^\circ$

The horizontal component of the force is

$$F_x = F \cos \theta = 72 \times \cos 60^\circ \\ = 72 \times 0.5 = 36 \text{ dyne}$$

Acceleration,

$$a = \frac{F_x}{m} = \frac{36}{9} = 4 \text{ cm s}^{-2}$$

**EXAMPLE 4.** A scooterist moving with a speed of  $36 \text{ kmh}^{-1}$  sees a child standing in the middle of the road. He applies the brakes and brings the scooter to rest in 5 s just in time to save child. Calculate the average retarding force on the vehicle, if mass of the vehicle and driver is 300 kg.

**Solution.** Here  $u = 36 \text{ kmh}^{-1} = 10 \text{ ms}^{-1}$ ,  $v = 0$ ,  $t = 5 \text{ s}$

$$a = \frac{v-u}{t} = \frac{0-10}{5} = -2 \text{ ms}^{-2}$$

$\therefore$  Retardation =  $2 \text{ ms}^{-2}$

$$\text{Average retarding force} = \text{Mass} \times \text{retardation} \\ = 300 \times 2 = 600 \text{ N}$$



**EXAMPLE 5.** A bus starts from rest accelerating uniformly with  $4 \text{ ms}^{-2}$ . At  $t = 10 \text{ s}$ , a stone is dropped out of a window of the bus  $2 \text{ m}$  high. What are the (i) magnitude of velocity and (ii) acceleration of the stone at  $10.2 \text{ s}$ ? Take  $g = 10 \text{ ms}^{-2}$ .

**Solution.** (i) Horizontal velocity of the bus or the stone at  $t = 10 \text{ s}$  is

$$v_x = u + at = 0 + 4 \times 10 = 40 \text{ ms}^{-1}$$

For vertical motion of the stone,

$$u = 0, a = g = 10 \text{ ms}^{-2}, t = 10.2 - 10 = 0.2 \text{ s}$$

$$\therefore v_y = 0 + 10 \times 0.2 = 2 \text{ ms}^{-1}$$

Magnitude of the resultant velocity of the stone is

$$v = \sqrt{v_x^2 + v_y^2} = \sqrt{40^2 + 2^2} = \sqrt{1604} = 40.04 \text{ ms}^{-1}.$$

(ii) After the stone is dropped, its acceleration along horizontal is zero. It has only a vertical acceleration of  $10 \text{ ms}^{-2}$ .

**EXAMPLE 6.** Forces of  $5\sqrt{2} \text{ N}$  and  $6\sqrt{2} \text{ N}$  are acting on a body of mass  $1000 \text{ kg}$  at an angle to  $60^\circ$  to each other. Find the acceleration, distance covered and the velocity of the mass after  $10 \text{ s}$ .

**Solution.**

$$\begin{aligned} F &= \sqrt{F_1^2 + F_2^2 + 2F_1 F_2 \cos \theta} \\ &= \sqrt{(5\sqrt{2})^2 + (6\sqrt{2})^2 + 2 \times 5\sqrt{2} \times 6\sqrt{2} \cos 60^\circ} \\ &= \sqrt{50 + 72 + 60} = \sqrt{182} = 13.49 \text{ N} \end{aligned}$$

$$a = \frac{F}{m} = \frac{13.49}{1000} = 0.01349 \text{ ms}^{-2}$$

$$v = u + at = 0 + 0.01349 \times 10 = 0.1349 \text{ ms}^{-1}$$

$$s = 0 + \frac{1}{2} \times 0.01349 \times (10)^2 = 0.6745 \text{ m}.$$

**EXAMPLE 7.** A block of metal weighing  $2 \text{ kg}$  is resting on a frictionless plane. It is struck by a jet releasing water at the rate of  $1 \text{ kg s}^{-1}$  and at a speed of  $5 \text{ ms}^{-1}$ . Calculate the initial acceleration of the block.

**Solution.** Force exerted by the jet of water on the block is

$$F = \frac{dp}{dt} = \frac{d}{dt}(mv) = v \frac{dm}{dt} = 5 \text{ ms}^{-1} \times 1 \text{ kgs}^{-1} = 5 \text{ N}$$

Mass of block,

$$m = 2 \text{ kg}$$

$\therefore$  Acceleration of the block,

$$a = \frac{F}{m} = \frac{5}{2} = 2.5 \text{ ms}^{-2}.$$

**EXAMPLE 8.** A body of mass  $m$  moves along X-axis such that its position co-ordinate at any instant  $t$  is

$$x = at^4 - bt^3 + ct,$$

where  $a$ ,  $b$  and  $c$  are constants. What is the force acting on the particle at any instant  $t$ ?

**Solution.** Position co-ordinate,  $x = at^4 - bt^3 + ct$

$$\text{Velocity} = \frac{dx}{dt} = 4at^3 - 3bt^2 + c$$

$$\begin{aligned} \text{Acceleration} &= \frac{d^2x}{dt^2} = \frac{d}{dt}(4at^3 - 3bt^2 + c) \\ &= 12at^2 - 6bt \end{aligned}$$

$$\begin{aligned} \text{Force} &= \text{Mass} \times \text{acceleration} \\ &= m(12at^2 - 6bt). \end{aligned}$$

### ✖ PROBLEMS FOR PRACTICE

- A force acts for  $10 \text{ s}$  on a body of mass  $10 \text{ kg}$  after which the force ceases and the body describes  $50 \text{ m}$  in the next  $5 \text{ s}$ . Find the magnitude of the force.  
(Ans.  $10 \text{ N}$ )
- A truck starts from rest and rolls down a hill with constant acceleration. It travels a distance of  $400 \text{ m}$  in  $20 \text{ s}$ . Calculate the acceleration and the force acting on it if its mass is  $7 \text{ metric tonnes}$ .  
(Ans.  $2 \text{ ms}^{-2}$ ,  $14,000 \text{ N}$ )
- A force of  $5 \text{ N}$  gives a mass  $m_1$  an acceleration of  $8 \text{ ms}^{-2}$  and a mass  $m_2$  an acceleration of  $24 \text{ ms}^{-2}$ . What acceleration would it give if both the masses are tied together?  
(Ans.  $6 \text{ ms}^{-2}$ )
- In an X-ray machine, an electron is subjected to a force of  $10^{-23} \text{ N}$ . In how much time the electron will cover a distance of  $0.1 \text{ m}$ ? Take mass of the electron =  $10^{-30} \text{ kg}$ .  
(Ans.  $1.4 \times 10^{-4} \text{ s}$ )
- A stone of mass  $5 \text{ kg}$  falls from top of a cliff  $50 \text{ m}$  high and buries  $1 \text{ m}$  in sand. Find the average resistance offered by the sand and the time it takes to penetrate.  
(Ans.  $2450 \text{ N}$ ,  $0.064 \text{ s}$ )
- A bullet of mass  $100 \text{ g}$  moving with  $20 \text{ m/s}$  strikes a wooden plank and penetrates upto  $20 \text{ cm}$ . Calculate the resistance offered by the wooden plank.  
[Delhi 96] (Ans.  $100 \text{ N}$ )
- A motor car running at the rate of  $7 \text{ ms}^{-1}$  can be stopped by applying brakes in  $10 \text{ m}$ . Show that total resistance to the motion, when brakes are on, is one fourth of the weight of the car.
- A force of  $50 \text{ N}$  is inclined to the vertical at an angle of  $30^\circ$ . Find the acceleration it produces in a body of mass  $2 \text{ kg}$  which moves in the horizontal direction.  
(Ans.  $12.5 \text{ ms}^{-2}$ )
- A ship of mass  $3 \times 10^7 \text{ kg}$  and initially at rest can be pulled through a distance of  $3 \text{ m}$  by means of a force of  $5 \times 10^4 \text{ N}$ . The water resistance is negligible. Find the speed attained by the ship. [IIT 80]  
(Ans.  $0.1 \text{ ms}^{-1}$ )

10. A balloon has a mass of 5 g in air. The air escapes from the balloon at a uniform rate with a velocity of  $5 \text{ cms}^{-1}$ . If the balloon shrinks completely in 2.5 s, find the average force acting on the balloon.

(Ans. 10 dyne)

### X HINTS

1. After the force ceases, the body covers 50 m in 5 s, so final velocity of the body is

$$v = \frac{\text{Distance}}{\text{Time}} = \frac{50 \text{ m}}{5 \text{ s}} = 10 \text{ ms}^{-1}$$

But  $v = u + at$

$$\therefore 10 = 0 + a \times 10 \quad \text{or} \quad a = 1 \text{ ms}^{-2}$$

$$\therefore F = ma = 10 \text{ kg} \times 1 \text{ ms}^{-2} = 10 \text{ N.}$$

2. As  $s = ut + \frac{1}{2}at^2$

$$\therefore 400 = 0 + \frac{1}{2}a(20)^2$$

$$\text{or} \quad a = 2 \text{ ms}^{-2}$$

$$\text{and} \quad F = ma = 7000 \times 2 = 14,000 \text{ N.}$$

3. Here  $m_1 = \frac{F}{a_1} = \frac{5}{8} \text{ kg}$

$$\text{and} \quad m_2 = \frac{F}{a_2} = \frac{5}{24} \text{ kg}$$

$$\therefore m_1 + m_2 = \frac{5}{8} + \frac{5}{24} = \frac{5}{6} \text{ kg}$$

Acceleration of the tied masses

$$= \frac{F}{m_1 + m_2} = \frac{5}{5/6} = 6 \text{ ms}^{-2}.$$

4. Here  $a = \frac{F}{m} = \frac{10^{-23}}{10^{-30}} = 10^7 \text{ ms}^{-2}$

$$\text{As} \quad s = ut + \frac{1}{2}at^2$$

$$\therefore 0.1 = 0 + \frac{1}{2} \times 10^7 \times t^2$$

$$\text{or} \quad t^2 = 2 \times 10^{-8} \text{ s}^2$$

$$\text{or} \quad t = 1.4 \times 10^{-4} \text{ s.}$$

5. Velocity attained by the stone as it falls through a height of 50 m is given by

$$v^2 - u^2 = 2as$$

$$\text{or} \quad v^2 - 0^2 = 2 \times 9.8 \times 50$$

$$\text{or} \quad v = \sqrt{980} \text{ ms}^{-1}$$

Now the stone starts burying into sand with a velocity of  $\sqrt{980} \text{ ms}^{-1}$  and finally comes to rest after travelling a distance,  $s = 1 \text{ m}$ .

$$\therefore 0^2 - 980 = 2a \times 1$$

$$\text{or} \quad a = -490 \text{ ms}^{-2}$$

Average resistance offered by sand,

$$F = ma = 5 \times 490 = 2450 \text{ N.}$$

Time taken by stone to penetrate sand,

$$t = \frac{v - u}{a} = \frac{0 - \sqrt{980}}{-490} = 0.064 \text{ s.}$$

6. As  $v^2 - u^2 = 2as$

$$\therefore 0 - (20)^2 = 2a \times 0.20$$

$$\text{or} \quad a = -1000 \text{ ms}^{-2}$$

Retarding force = Mass  $\times$  retardation

$$= 0.100 \times 1000 = 100 \text{ N.}$$

7. Here  $u = 7 \text{ ms}^{-1}$ ,  $v = 0$ ,  $s = 10 \text{ m}$ ,  $a = ?$

$$\text{As} \quad v^2 - u^2 = 2as \quad \therefore 0 - 7^2 = 2a \times 10$$

$$\text{or} \quad a = -2.45 \text{ ms}^{-2} = -\frac{9.8 \text{ ms}^{-1}}{4} = -\frac{g}{4}$$

Total resistance to motion

$$= -ma = \frac{mg}{4} = \frac{1}{4} \times \text{Weight of car.}$$

8. Horizontal component of force

$$= F \cos(90^\circ - \theta) = F \sin \theta$$

$$\therefore a = \frac{F \sin \theta}{m} = \frac{50 \sin 30^\circ}{2} = \frac{50 \times 1}{2 \times 2} = 12.5 \text{ ms}^{-2}.$$

9. Acceleration,  $a = \frac{F}{m} = \frac{5 \times 10^4}{3 \times 10^7} = \frac{5}{3} \times 10^{-3} \text{ ms}^{-2}$

Also  $u = 0$ ,  $s = 3 \text{ m}$

$$\text{As} \quad v^2 - u^2 = 2as$$

$$\therefore v^2 - 0 = 2 \times \frac{5}{3} \times 10^{-3} \times 3$$

$$\text{or} \quad v = 10^{-1} \text{ ms}^{-1} = 0.1 \text{ ms}^{-1}.$$

10. Force,  $F = \frac{dp}{dt} = \frac{d}{dt}(mv) = v \frac{dm}{dt}$  [ $\because v$  is constant]

$$\text{But} \quad \frac{dm}{dt} = \frac{5 \text{ g}}{2.5 \text{ s}} = 2 \text{ gs}^{-1} \text{ and } v = 5 \text{ cms}^{-1}$$

$$\therefore F = 5 \times 2 = 10 \text{ dyne.}$$

### 5.10 IMPULSE

27. What are impulsive forces? Give examples.

**Impulsive force.** A large force acting for a short time to produce a finite change in momentum is called an impulsive force.

**Examples :**

- Force exerted by a bat while hitting a ball.
- Blow of a hammer on a nail.
- Force experienced by a person when he falls from a certain height on a marble floor.

Impulsive forces usually vary in an abrupt and complicated manner. It is difficult to measure force and time duration separately in such situations. But the product of force and time, which is equal to the change in momentum of the body, is a measurable quantity. This product is given the name *impulse*.

**28.** What do you mean by impulse of a force? Show that impulse is equal to the product of average force and the time interval for which the force acts. Give the units and dimensions of impulse.

**Impulse of a force.** Impulse is the total effect of a large force which acts for a short time to produce a finite change in momentum. Impulse is defined as the product of the force and the time for which it acts and is equal to the total change in momentum.

$$\begin{aligned} \text{Impulse} &= \text{Force} \times \text{time duration} \\ &= \text{Total change in momentum} \end{aligned}$$

Impulse is a vector quantity denoted by  $\vec{J}$ . Its direction is same as that of force or the change in momentum. The impulse of a force is positive, negative or zero depending on the momentum of the body increases, decreases or remains unchanged.

**Impulse as the product of force and time.** Suppose a force  $\vec{F}$  acts for a small time  $dt$ . The impulse of the force is given by

$$d\vec{J} = \vec{F} dt$$

If we consider a finite interval of time from  $t_1$  to  $t_2$ , then the impulse will be

$$\vec{J} = \int d\vec{J} = \int_{t_1}^{t_2} \vec{F} dt$$

If  $\vec{F}_{av}$  is the average force, then

$$\begin{aligned} \vec{J} &= \int_{t_1}^{t_2} \vec{F}_{av} dt = \vec{F}_{av} \int_{t_1}^{t_2} dt \\ &= \vec{F}_{av} [t]_{t_1}^{t_2} = \vec{F}_{av} (t_2 - t_1) \end{aligned}$$

or 
$$\vec{J} = \vec{F}_{av} \times \Delta t, \quad \text{where } \Delta t = t_2 - t_1$$

Thus, the impulse of a force is equal to the product of the average force and the time interval for which it acts.

- Dimensions of impulse =  $[MLT^{-1}]$
- SI unit of impulse =  $kg \text{ ms}^{-1}$
- CGS unit of impulse =  $g \text{ cm s}^{-1}$ .

**29.** Show that the impulse of a force is equal to the change in momentum produced by the force.

**Impulse-momentum theorem.** According to Newton's second law of motion,

Applied force = Rate of change of momentum

$$\vec{F} = \frac{d\vec{p}}{dt} \quad \text{or} \quad \vec{F} dt = d\vec{p}$$

If in time 0 to  $t$ , the momentum of the body changes from  $\vec{p}_1$  to  $\vec{p}_2$ , then integrating the above equation within these limits, we get

$$\int_0^t \vec{F} dt = \int_{\vec{p}_1}^{\vec{p}_2} d\vec{p} = [\vec{p}]_{\vec{p}_1}^{\vec{p}_2} = \vec{p}_2 - \vec{p}_1$$

But 
$$\int_0^t \vec{F} dt = \text{Impulse, } \vec{J} \quad \therefore \vec{J} = \vec{p}_2 - \vec{p}_1$$

Thus, the impulse of a force is equal to the total change in momentum produced by the force. This relationship between impulse and momentum is known as **impulse-momentum theorem**.

**30.** Briefly explain how the impulse of a force can be measured graphically.

**Measurement of impulse by graphical method.**

**A. When a constant force acts on a body.** Suppose a constant force  $F$  acts on a body from time  $t_1$  to  $t_2$ . The force-time graph is a straight line  $AB$  parallel to the time-axis, as shown in Fig. 5.6.

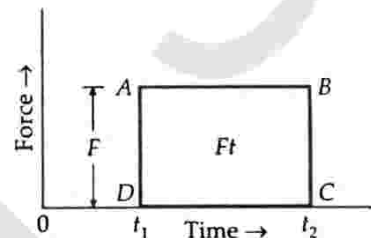

**Fig. 5.6** Impulse of a constant force.

Area of rectangle  $ABCD$

$$= AD \times AB = F (t_2 - t_1) = F \times t$$

= Magnitude of impulse of force  $F$  in time interval  $t$

**B. When a variable force acts on the body.** Suppose a force varying in magnitude acts on a body for time  $t_2 - t_1 = t$ . The force-time graph is a curve  $ABC$  as shown in Fig. 5.7.

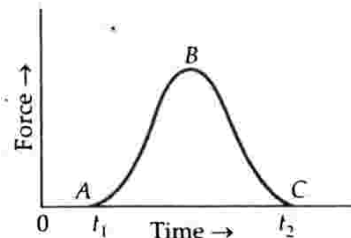

**Fig. 5.7** Impulse of a variable force.

Impulse of force  $F$  in time interval  $t$ ,

$$J = \int_0^t F dt = \text{Area under the force-time curve } ABC.$$

Thus, the area under the force-time graph gives the magnitude of the impulse of the given force in the given time interval.

### 5.11 APPLICATIONS OF THE CONCEPT OF IMPULSE

31. Give some practical examples from daily life which make use of the concept of impulse.

**Practical applications of impulse.** We know that

$$\begin{aligned} \text{Impulse of a force} &= \text{Force} \times \text{time} \\ &= \text{Change in momentum} \end{aligned}$$

If two forces  $\vec{F}_1$  and  $\vec{F}_2$  act on a body to produce the same impulse (or change in momentum), then their time durations  $t_1$  and  $t_2$  should be such that

$$\vec{F}_1 t_1 = \vec{F}_2 t_2$$

Clearly, if the time duration of an impulse is large, the force exerted will be small. The following examples will make clear this concept.

(i) **A cricket player lowers his hands while catching a ball.** When the ball is caught, the impulse received by the hands is equal to the product of the force exerted by the ball and the time taken to complete the catch. By moving the hands backwards, the cricketer increases the time of catch. The force exerted on his hands becomes much smaller and it does not hurt him.

(ii) **A person falling from a certain height receives more injuries when he falls on a cemented floor than when he falls on a heap of sand.** In both cases, the impulse or the total change in momentum is same. On the cemented floor, the person is stopped abruptly. So the cemented floor exerts a large force of reaction causing him severe injuries. When the person falls on a heap of sand, the sand yields (gets depressed) under his weight. The person takes longer time to stop. This decreases the force exerted by the floor on the person.

(iii) **Automobiles (cars, buses, etc) are provided with shockers.** When a vehicle moves on an uneven road, it receives a jerk. The shocker increases the time of jerk and hence reduces its force. This makes journey comfortable and saves the automobile from damage due to bumps.

(iv) **Buffers are provided between the boggies of a train.** Buffers increase the time of jerk during shunting. This decreases the force of impact between the bogies. The bogies are thus prevented from receiving severe jerks.

(v) **Chinawares are packed in straw paper before packing.** The straw paper between the chinawares increases the time of experiencing the jerk during transportation. Hence, they strike against each other with a lesser force and are less likely to be damaged.

### Examples based on Impulse of a Force

#### FORMULAE USED

- Impulse = Force  $\times$  time = Change in momentum  
or  $J = F \times t = m(v - u)$
- $\vec{J} = \int_{t_1}^{t_2} \vec{F} \cdot dt = \text{Area under force-time (F-t) graph}$

#### UNITS USED

Velocities  $u$  and  $v$  are in  $\text{ms}^{-1}$ , mass  $m$  in kg, time  $t$  in second, force  $F$  in newton and impulse  $J$  in Ns or  $\text{kg ms}^{-1}$ .

**EXAMPLE 9.** A batsman hits back a ball straight in the direction of the bowler without changing its initial speed of  $12 \text{ ms}^{-1}$ . If the mass of the ball is  $0.15 \text{ kg}$ , determine the impulse imparted to the ball. (Assume linear motion of the ball.)

[NCERT]

**Solution.** Here

$$m = 0.15 \text{ kg}, u = 12 \text{ ms}^{-1}, v = -12 \text{ ms}^{-1}$$

$$\text{Impulse} = m(v - u) = 0.15(-12 - 12) = -3.6 \text{ Ns}$$

The negative sign indicates that the direction of the impulse is from the batsman to the bowler.

**EXAMPLE 10.** A cricket ball of mass  $150 \text{ g}$  moving with a velocity of  $15 \text{ ms}^{-1}$  is brought to rest by a player in  $0.05 \text{ s}$ . Calculate the impulse and the average force exerted by the player.

**Solution.** Here  $m = 150 \text{ g} = 0.15 \text{ kg}$ ,  $u = 15 \text{ ms}^{-1}$ ,  $v = 0$ ,  $t = 0.05 \text{ s}$

$$\text{Impulse} = m(v - u) = 0.15(0 - 15) = -2.25 \text{ Ns}$$

$$\text{Average force} = \frac{\text{Impulse}}{\text{Time}} = \frac{-2.25}{0.05} = -45 \text{ N}$$

The negative sign indicates the retarding nature of the force.

**EXAMPLE 11.** A rubber ball of mass  $50 \text{ g}$  falls from a height of  $1 \text{ m}$  and rebounds to a height of  $0.5 \text{ m}$ . Find the impulse and the average force between the ball and the ground if the time for which they are in contact was  $0.1 \text{ s}$ .

**Solution.** Refer to Fig. 5.8. Initial velocity of ball at  $A = 0$ .

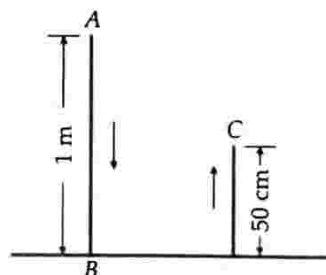

Fig. 5.8

Final velocity of ball at  $B = v$

$$s = 1 \text{ m}$$

As  $v^2 - u^2 = 2as$

$$v^2 - 0^2 = 2 \times 9.8 \times 1 \text{ or } v = \sqrt{19.6} \text{ ms}^{-1}$$

Let  $u'$  be the velocity of rebound of the ball.

$$s' = 50 \text{ cm} = 0.5 \text{ m}, g = -9.8 \text{ ms}^{-2}$$

Final velocity at  $C = v' = 0$

As  $v'^2 - u'^2 = 2as$

$$\therefore 0^2 - (u')^2 = 2 \times (-9.8) \times 0.5$$

or  $u' = \sqrt{9.8} \text{ ms}^{-1}$

Now, Impulse = Change in momentum

$$= mv - (-mu') = mv + mu' = m(v + u')$$

$$= \frac{50}{1000} (\sqrt{19.6} + \sqrt{9.8})$$

$$= \frac{1}{20} (4.427 + 3.130) = 0.378 \text{ N s}$$

$$\text{Average force} = \frac{\text{Impulse}}{\text{Time}} = \frac{0.378}{0.1} = 3.78 \text{ N.}$$

**EXAMPLE 12.** While launching a rocket of mass  $2 \times 10^4 \text{ kg}$ , a force of  $5 \times 10^5 \text{ N}$  is applied for 20 s. Calculate the velocity attained by the rocket at the end of 20 s.

**Solution.** Here  $m = 2 \times 10^4 \text{ kg}$ ,  $F = 5 \times 10^5 \text{ N}$ ,

$$t = 20 \text{ s}, u = 0, v = ?$$

$$\text{Impulse of force} = F \times t = m(v - u)$$

$$\therefore 5 \times 10^5 \times 20 = 2 \times 10^4 (v - 0)$$

or  $v = \frac{5 \times 10^5 \times 20}{2 \times 10^4} = 500 \text{ ms}^{-1}$ .

**EXAMPLE 13.** A machine gun fires a bullet of mass 40 g with a speed of  $1200 \text{ ms}^{-1}$ . The person holding the gun can exert a maximum force of 144 N on it. What is the number of bullets that can be fired from the gun per second? [AIEEE 04]

**Solution.** Let maximum number of bullets that can be fired per second =  $n$

$\therefore$  Change in momentum of  $n$  bullets

$$= nm(v - u)$$

$$= n \times \frac{40}{1000} (1200 - 0) = 48n \text{ kg ms}^{-1}$$

As impulse = Change in momentum

$$\therefore Ft = 48n$$

or  $n = \frac{Ft}{48} = \frac{144 \times 1}{48} = 3 \text{ bullets/s.}$

**EXAMPLE 14.** A ball moving with a momentum of  $5 \text{ kg ms}^{-1}$  strikes against a wall at an angle of  $45^\circ$  and is reflected at the same angle. Calculate the change in momentum. [Chandigarh 09]

**Solution.** Initial momentum is along  $AO$ . It has two rectangular components :

$$p \cos 45^\circ \text{ along } CO \text{ and } p \sin 45^\circ \text{ along } DO$$

Final momentum  $p$  is along  $OB$ . It has two rectangular components :

$$p \cos 45^\circ \text{ along } OC \text{ and } p \sin 45^\circ \text{ along } OE$$

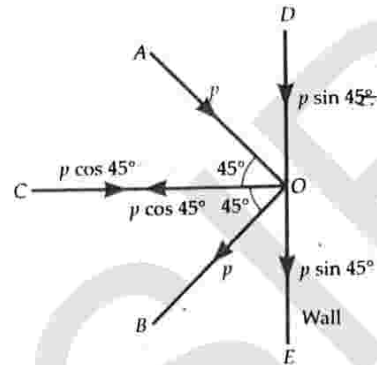

**Fig. 5.9**

Change in momentum along vertical direction

$$= \text{Final momentum} - \text{Initial momentum}$$

$$= p \sin 45^\circ - p \sin 45^\circ = 0$$

Change in momentum along horizontal direction

$$= -p \cos 45^\circ - p \cos 45^\circ = -2p \cos 45^\circ$$

$$= -2 \times 5 \times \frac{1}{\sqrt{2}} = -2 \times 5 \times 0.707$$

$$= -7.07 \text{ kg ms}^{-1}$$

Negative sign indicates that the direction of change in momentum is away from the wall.

**EXAMPLE 15.** The initial speed of a body of mass  $2.0 \text{ kg}$  is  $5.0 \text{ ms}^{-1}$ . A force acts for 4 s in the direction of motion of the body. The force-time graph is shown in Fig. 5.10. Calculate the impulse of the force and the final speed of the body.

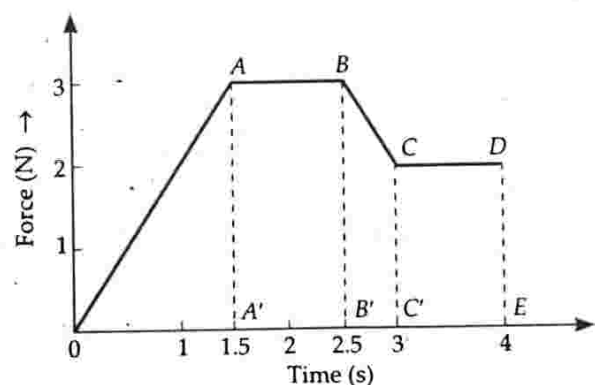

**Fig. 5.10**

**Solution.** Impulse of a force

$$= \text{Area between the force-time graph and the time-axis}$$

$$\begin{aligned}
 &= \text{Area of triangle } OA'A \\
 &\quad + \text{Area of rectangle } AA'B'B \\
 &\quad + \text{Area of trapezium } BB'C'C \\
 &\quad + \text{Area of rectangle } CC'ED \\
 &= \frac{1}{2} \times 1.5 \times 3 + 1 \times 3 + \frac{1}{2} (3 + 2)(3 - 2.5) + 2 \times 1 \\
 &= 2.25 + 3 + 1.25 + 2 = 8.50 \text{ Ns.}
 \end{aligned}$$

As impulse = Change in momentum =  $m\Delta v$

$\therefore$  Change in velocity,

$$\Delta v = \frac{\text{Impulse}}{m} = \frac{8.50}{2} = 4.25 \text{ ms}^{-1}$$

Final speed of the body

$$= \text{Initial speed} + \Delta v = 5.0 + 4.25 = 9.25 \text{ ms}^{-1}.$$

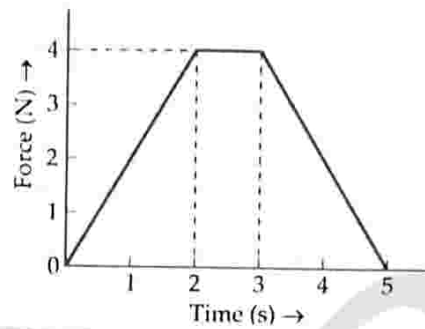

Fig. 5.11

8. Fig. 5.12 shows an estimated force-time graph for a base ball struck by a bat.

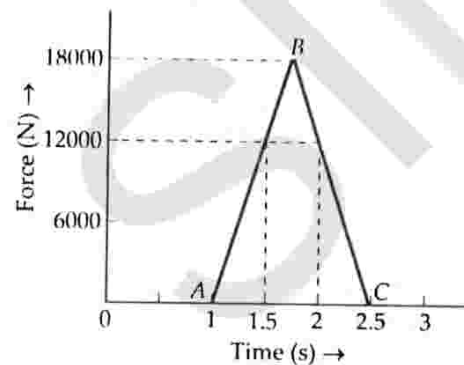

Fig. 5.12

From this curve, determine (i) impulse delivered to the ball (ii) force exerted on the ball (iii) the maximum force on the ball.

$$[\text{Ans. (i) } 1.35 \times 10^4 \text{ kg ms}^{-1}$$

$$(ii) 9000 \text{ N (iii) } 18000 \text{ N}]$$

### ❖ PROBLEMS FOR PRACTICE

- A cricket ball of mass 150 g is moving with a velocity of  $12 \text{ ms}^{-1}$ , and is hit by a bat, so that the ball is turned back with a velocity of  $20 \text{ ms}^{-1}$ . The force of the blow acts for 0.01 second on the ball. Find the average force exerted by the bat on the ball. [Central Schools 04, 05, 07] (Ans.  $4800 \text{ N}$ )
- A hammer weighing 1 kg moving with the speed of  $10 \text{ ms}^{-1}$  strikes the head of a nail driving it 10 cm into a wall. Neglecting the mass of the nail, calculate (i) the acceleration during impact (ii) the time interval of the impact and (iii) the impulse. [Ans. (i)  $-500 \text{ ms}^{-2}$  (ii) 0.02 s (iii)  $-10 \text{ Ns}$ ]
- Two billiard balls of mass 50 g moving in opposite directions with speed of  $16 \text{ ms}^{-1}$  collide and rebound with the same speed. What is the impulse imparted by each ball to the other? (Ans.  $-1.6 \text{ kg ms}^{-1}$ ,  $+1.6 \text{ kg ms}^{-1}$ )
- A machine gun has a mass of 20 kg. It fires 30 g bullets at the rate of 400 bullets per second with a speed of  $400 \text{ ms}^{-1}$ . What force must be applied to the gun to keep it in position? (Ans. 4800 N)
- A ball of mass 20 g hits a wall at an angle of  $45^\circ$  with a velocity of  $15 \text{ ms}^{-1}$ . If the ball rebounds at  $90^\circ$  to the direction of incidence, calculate the impulse received by the ball. (Ans.  $0.42 \text{ kg ms}^{-1}$ )
- A glass ball whose mass is 10 g falls from a height of 40 m and rebounds to a height of 10 m. Find the impulse and the average force between the glass ball and the floor if the time during which they are in contact is 0.1 s. (Ans. 0.42 Ns, 4.2 N)
- A force acting on a body of mass 2 kg varies with time as shown in Fig. 5.11. Find (i) impulse of the force and (ii) the final velocity of the body. [Ans. (i)  $12 \text{ kg ms}^{-1}$  (ii)  $6 \text{ ms}^{-1}$ ]

- A ball moving with a momentum of  $15 \text{ kg ms}^{-1}$  strikes against the wall at an angle of  $30^\circ$  and is reflected with the same momentum at the same angle. Calculate impulse. [Chandigarh 08] (Ans.  $-15\sqrt{3} \text{ kg ms}^{-1}$ )

- Calculate the impulse necessary to stop a 1500 kg car travelling at 90 km/h. [Delhi 97] (Ans.  $-37500 \text{ Ns}$ )
- A body of mass 0.25 kg moving with velocity 12 m/s is stopped by applying a force of 0.6 N. Calculate the time taken to stop the body. Also calculate the impulse of this force. [Delhi 99] (Ans. 5 s, 3 Ns)

### ❖ HINTS

- Here  $m = 150 \text{ g} = 0.15 \text{ kg}$ ,  $u = 12 \text{ ms}^{-1}$ ,  
 $v = -20 \text{ ms}^{-1}$ ,  $t = 0.01 \text{ s}$   
 Impulse =  $m(v - u) = 0.15(-20 - 12)$   
 $= -4.8 \text{ kg ms}^{-1}$

$$\text{Average force} = \frac{\text{Impulse}}{\text{Time}} = \frac{4.8}{0.01} = 480 \text{ N.}$$

2. Here  $u = 10 \text{ ms}^{-1}$ ,  $v = 0$ ,  $s = 10 \text{ cm} = 0.1 \text{ m}$

(i) As  $v^2 - u^2 = 2as$

$$\therefore 0^2 - 10^2 = 2a \times 0.1 \text{ or } a = \frac{-100}{2 \times 0.1} = -500 \text{ ms}^{-2}$$

(ii) As  $v = u + at$

$$\therefore t = \frac{v - u}{a} = \frac{0 - 10}{-500} = \frac{10}{500} = 0.02 \text{ s}$$

(iii) Impulse =  $F \times t = ma \times t$

$$= 1 \times (-500) \times 0.02 = -10 \text{ N}$$

6. For downward motion of the ball :

$$u = 0, h = 40 \text{ m}, g = +9.8 \text{ ms}^{-2}$$

As  $v^2 - u^2 = 2gh$

$$\therefore v^2 - 0 = 2 \times 9.8 \times 40$$

or  $v = \sqrt{784} = 28 \text{ ms}^{-1}$

For upward motion of the ball :

$$u = ?, h = 10 \text{ m}, v = 0 \quad (\text{at the highest point}),$$

$$g = -9.8 \text{ ms}^{-2}$$

As  $v^2 - u^2 = 2gh$

$$\therefore 0 - u^2 = -2 \times 9.8 \times 10$$

or  $u = \sqrt{196} = 14 \text{ ms}^{-1}$

$\therefore$  Change in velocity of the ball

$$= 28 - (-14) = 42 \text{ ms}^{-1}$$

Impulse = Change in momentum

$$= \text{Mass} \times \text{Change in velocity}$$

$$= \frac{10}{1000} \text{ kg} \times 42 \text{ ms}^{-1} = 0.42 \text{ N s}$$

$$\text{Average force} = \frac{\text{Impulse}}{\text{Time}} = \frac{0.42}{0.1} = 4.2 \text{ N}$$

8. (i) Impulse = Area ABC

$$= \frac{1}{2} \times 18000 \times (2.5 - 1)$$

$$= 1.35 \times 10^4 \text{ kg ms}^{-1}$$

(ii) Force =  $\frac{\text{Impulse}}{\text{Time}}$

$$= \frac{1.35 \times 10^4}{(2.5 - 1)} = 9000 \text{ N}$$

(iii) Maximum force = 18000 N

10. Here  $m = 1500 \text{ kg}$ ,  $u = 90 \text{ kmh}^{-1} = 25 \text{ ms}^{-1}$ ,  $v = 0$

$$\text{Impulse} = m(v - u) = 1500(0 - 25)$$

$$= -37500 \text{ N s}$$

11. Here  $m = 0.25 \text{ kg}$ ,  $u = 12 \text{ ms}^{-1}$ ,  $v = 0$ ,  $F = -0.6 \text{ N}$

$$a = \frac{F}{m} = \frac{-0.6}{0.25} = -2.4 \text{ ms}^{-2}$$

$$t = \frac{v - u}{a} = \frac{0 - 12}{-2.4} = 5 \text{ s}$$

$$\text{Impulse} = Ft = -0.6 \times 5 = 3 \text{ N s}$$

## 5.12 DISCUSSION OF NEWTON'S THIRD LAW OF MOTION

32. State and explain Newton's third law of motion.

**Newton's third law of motion.** It states that

*To every action, there is always an equal and opposite reaction.*

In simple terms, third law can be stated as follows :

*Forces in nature always occur between pairs of bodies.*

*Force on body A by body B is equal and opposite to the force on the body B by A.*

As shown in Fig. 5.13, if  $\vec{F}_{BA}$  is the force exerted by body A on B and  $\vec{F}_{AB}$  is the force exerted by B on A, then according to Newton's third law,

$$\vec{F}_{AB} = -\vec{F}_{BA}$$

Force on A by B = - Force on B by A

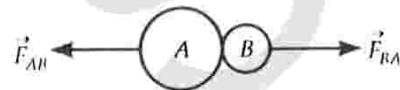

Fig. 5.13 Newton's third law.

For example, while swimming a man pushes water backward and in turn ; he is pushed forward, due to the reaction of water.

The above discussion shows that a *single force can never exist.*

*The forces always exist in pairs.* The two forces act simultaneously. Any one of them may be called the action and the other reaction. No cause-effect relationship exists between action and reaction.

33. Give some important implications of the third law of motion.

**Some important points about the third law of motion :**

1. Newton's third law of motion is *applicable irrespective of the nature of the forces.* The forces of action and reactions may be mechanical, gravitational, electric or of any other nature.

2. *Action and reaction always act on different bodies.* If they acted on the same body, the resultant force would be zero and there could never be accelerated motion.

3. *The forces of action and reaction cannot cancel each other.* This is because action and reaction, though equal and opposite, always act on different bodies and so cannot balance each other.

4. *No action can occur in the absence of a reaction.* For example, in a tug-of-war, one team can pull the rope only if the other team is pulling the other end of the rope. No force can be exerted if the other end is free. One team exerts the force of action and the other team provides the force of reaction.

### 5.13 ▽ ILLUSTRATIONS OF NEWTON'S THIRD LAW OF MOTION

34. Give some examples from daily life which illustrate the use of Newton's law of motion.

Examples of Newton's third law of motion :

1. **Book kept on a table.** Consider a book of weight  $W$  resting on a table top. The book exerts a downward force (action) on the table equal to its own weight  $W$ . According to Newton's third law, the table also exerts an equal and upward force  $R$  (reaction) on the book such that

$$\vec{R} = -\vec{W}$$

As the book is under the action of two equal and opposite forces, it remains in equilibrium.

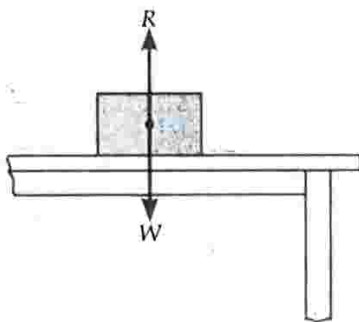

Fig. 5.14 Forces of action and reaction.

2. **While walking, we press the ground (action) with our feet slightly slanted in the backward direction.** The ground exerts an equal and opposite force on us. The vertical component of the force of reaction balances our weight and the horizontal component enables us to move forward, as shown in Fig. 5.15.

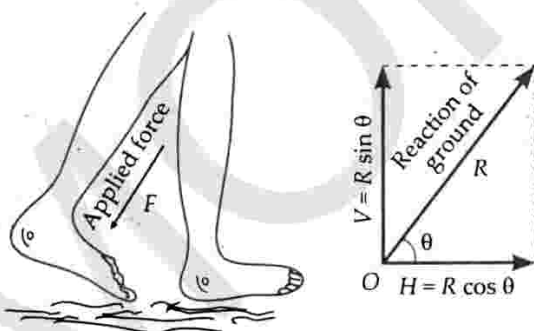

Fig. 5.15

3. **It is difficult to walk on a slippery ground or sand** because we are unable to push such a ground sufficiently hard. As a result, the force of reaction is not sufficient to help us move forward.

4. **It is difficult to drive a nail into a wooden block without supporting it.** When we hit the nail with a hammer, the nail and unsupported block together

move forward as a single system. There is no reaction. When the block is rested against a support, the reaction of the support holds the block in position and the nail is driven into the wooden block.

5. **While swimming, a person pushes water with his hands in the backward direction** (action) and water, in turn, pushes him forward due to the force of reaction.

6. **Rotatory lawn sprinkler.** The action of a rotatory lawn sprinkler is based on third law of motion. As water issues out of the nozzle, it exerts an equal and opposite force in the backward direction, causing the sprinkler to rotate in the opposite direction. Thus water is scattered in all directions.

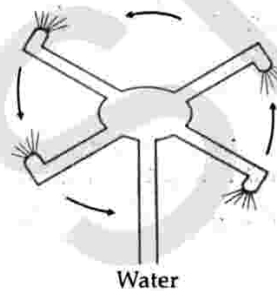

Fig. 5.16 Lawn sprinkler.

### 5.14 HORSE AND CART PROBLEM

35. Briefly explain how is a horse able to pull a cart.

**Horse and cart problem.** As shown in Fig. 5.17, consider a cart connected to a horse by a string. The horse while pulling the cart produces a tension  $T$  in the string in the forward direction (action). The cart, in turn, pulls the horse by an equal force  $T$  in the opposite direction.

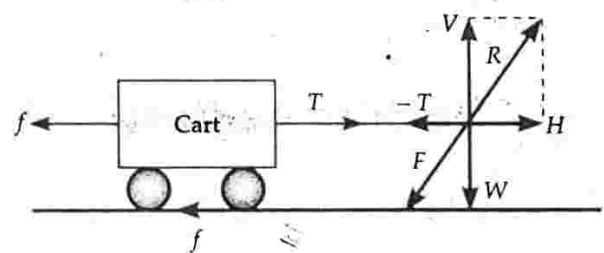

Fig. 5.17

Initially, the horse presses the ground with a force  $F$  in an inclined direction. The reaction  $R$  of the ground acts on the horse in the opposite direction. The reaction  $R$  has two rectangular components :

- The vertical component  $V$  which balances the weight  $W$  of the horse.
- The horizontal component  $H$  which helps the horse to move forward.

Let  $f$  be the force of friction.



The horse moves forward if  $H > T$ . In that case,  
net force acting on the horse =  $H - T$

If the acceleration of the horse is  $a$  and  $m$  is its mass, then

$$H - T = ma \quad \dots(1)$$

The cart moves forward if  $T > f$ . In that case,  
net force acting on the cart =  $T - f$

The weight of the cart is balanced by the reaction of the ground acting on it.

Obviously, the acceleration acting on the cart is also  $a$ . If  $M$  is the mass of the cart, then

$$T - f = Ma \quad \dots(2)$$

Adding (1) and (2), we get

$$H - f = (M + m)a$$

or 
$$a = \frac{H - f}{M + m}$$

Obviously,  $a$  is positive if  $H - f$  is positive, or if  $H > f$

Thus the system moves if  $H > f$ .

### 5.15 SECOND LAW IS THE REAL LAW OF MOTION

36. Show that Newton's second law of motion is the real law of motion.

Or

Show that Newton's first law and third law of motion are contained in the second law.

**A. First law is contained in the second law.**  
According to Newton's second law of motion, the force acting on a body is given by

$$F = ma$$

In the absence of any external force,

$$F = 0 \text{ or } ma = 0$$

As  $m \neq 0$ , therefore,  $a = 0$ .

Thus there is no acceleration when no force is applied. That is in the absence of any external force a body at rest will remain at rest and a body in uniform motion will continue to move uniformly along the same straight path. This is nothing but first law of motion. Hence first law of motion is contained in the second law.

**B. Third law is contained in the second law.**  
Consider an isolated system of two bodies  $A$  and  $B$ . Suppose the two bodies interact mutually with one another. Let  $\vec{F}_{BA}$  be the force (action) exerted by  $A$  on  $B$ .

Let  $\frac{d\vec{p}_B}{dt}$  be the resulting change of momentum of  $B$ . Let

$\vec{F}_{AB}$  be the force (reaction) exerted by  $B$  on  $A$ . Let  $\frac{d\vec{p}_A}{dt}$  be the resulting change of momentum of  $A$ . According to Newton's second law,

$$\vec{F}_{BA} = \frac{d\vec{p}_B}{dt} \quad \text{and} \quad \vec{F}_{AB} = \frac{d\vec{p}_A}{dt}$$

$$\therefore \vec{F}_{BA} + \vec{F}_{AB} = \frac{d\vec{p}_B}{dt} + \frac{d\vec{p}_A}{dt} = \frac{d}{dt}(\vec{p}_B + \vec{p}_A)$$

In the absence of external force, the rate of change of momentum must be zero i.e.,  $\frac{d}{dt}(\vec{p}_B + \vec{p}_A)$  must be zero.

$$\therefore \vec{F}_{BA} + \vec{F}_{AB} = 0$$

or  $\vec{F}_{BA} = -\vec{F}_{AB}$  or Action = - Reaction

This is nothing but Newton's third law of motion. Hence third law of motion is contained in the second.

As both first and third laws of motion are contained in the second law, we can say that *Newton's second law is the real law of motion.*

### 5.16 APPARENT WEIGHT OF A MAN IN AN ELEVATOR/LIFT

37. A man of mass  $m$  is standing on the floor of a lift. Find his apparent weight when the lift is (i) moving upwards with uniform acceleration  $a$  (ii) moving downwards with uniform acceleration  $a$  (iii) at rest or moving with uniform velocity  $v$  (iv) falling freely. Take acceleration due to gravity equal to  $g$ .

**Apparent weight of a man in a lift.** Consider a man of mass  $m$  standing on a weighing machine placed in a lift. The actual weight of the man is  $mg$ . It acts vertically downwards though the centre of gravity  $G$  of the man, it acts on the weighing machine which offers resistance  $R$ . The weighing machine reads the reaction  $R$  and which is the force experienced by the man. So  $R$  is the apparent weight of the man.

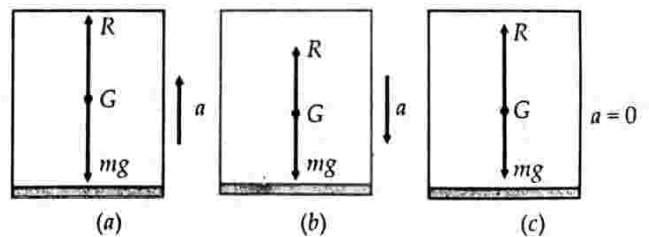

Fig. 5.18 Apparent weight of a man in a lift.

(i) When the lift moves upwards with acceleration  $a$ . As shown in Fig. 5.18(a), the net upward force on the man is

$$R - mg = ma$$

$$\therefore \text{Apparent weight, } R = m(g + a)$$

So when a lift accelerates upwards, the apparent weight of the man inside it increases.

(ii) When the lift moves downwards with acceleration  $a$ . As shown in Fig. 5.18(b), the net downward force on the man is

$$mg - R = ma$$

$$\therefore \text{Apparent weight, } R = m(g - a)$$

So when a lift accelerates downwards, the apparent weight of a man inside it decreases.

(iii) When the lift is at rest or moving with uniform velocity  $v$  downward/upward. As shown in Fig. 5.18(c), the acceleration  $a = 0$ . Net force on the man is

$$R - mg = m \times 0 = 0$$

$$R = mg$$

or Apparent weight = Actual weight.

(iv) When the lift falls freely. If the supporting cable of the lift breaks, the lift falls freely under gravity. Then  $a = g$ . The net downward force on the man is

$$R = m(g - g) = 0.$$

Thus the apparent weight of the man becomes zero. This is because both the man and the lift are moving downwards with the same acceleration ' $g$ ' and so there are no forces of action and reaction between the man and the lift. Hence a person develops a feeling of **weightlessness** when he falls freely under gravity.

### Examples based on

#### Newton's Third Law and Motion in a Lift

##### FORMULAE USED

- Reaction = - Action
- The apparent weight of a man in a lift :
  - When the lift moves upwards with acceleration  $a$ ,
 
$$R = m(g + a)$$
  - When the lift moves downwards with acceleration  $a$ ,
 
$$R = m(g - a)$$
  - When the lift falls freely,  $a = g$ , so
 
$$R = m(g - a) = m(g - g) = 0$$
  - When the lift is at rest or moves with uniform velocity,  $a = 0$ , so
 
$$R = m(g - 0) = mg$$

##### UNITS USED

The absolute SI unit of force is newton and CGS unit is dyne. The gravitational SI unit of force is kg f or kg wt and CGS unit is gf or gwt.

**EXAMPLE 16.** Two identical billiard balls strike a rigid wall with the same speed but at different angles, and get reflected without any loss of speed, as shown in Fig. 5.19. What is (i) the direction of the force of the wall due to each ball ? and (ii) the ratio of the magnitudes of the impulses imparted on the two balls by the wall ? [NCERT]

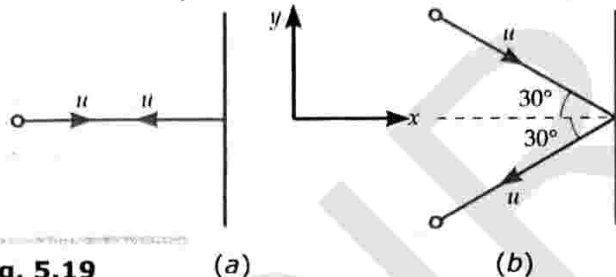

Fig. 5.19

**Solution.** (i) Let  $u$  be the speed of each ball before and after collision with the wall, and  $m$  be the mass of each ball. Choose  $x$ - and  $y$ -axes as shown.

In Fig. 5.19(a),

$$\begin{aligned} p_x^{\text{initial}} &= mu, & p_y^{\text{initial}} &= 0 \\ p_x^{\text{final}} &= -mu, & p_y^{\text{final}} &= 0 \end{aligned}$$

As impulse = change in momentum

$\therefore$   $x$ -component of impulse

$$= -mu - mu = -2mu.$$

$y$ -component of impulse =  $0 - 0 = 0$ .

Clearly, the direction of the impulse is along the negative  $x$ -direction of motion.

As the direction of the force is same as that of impulse, so the force on the ball due to the wall is normal to the wall, along the negative  $x$ -direction of motion.

By Newton's third law of motion, the force on the wall due to the ball is normal to the wall along the positive  $x$ -direction.

In Fig. 5.19(b),

$$\begin{aligned} p_x^{\text{initial}} &= mu \cos 30^\circ, & p_y^{\text{initial}} &= -mu \sin 30^\circ, \\ p_x^{\text{final}} &= -mu \cos 30^\circ, & p_y^{\text{final}} &= -mu \sin 30^\circ, \end{aligned}$$

$\therefore$   $x$ -component of impulse

$$\begin{aligned} &= -mu \cos 30^\circ - mu \cos 30^\circ \\ &= -2mu \cos 30^\circ \end{aligned}$$

$y$ -component of impulse

$$= -mu \sin 30^\circ + mu \sin 30^\circ = 0$$

Again, the direction of the impulse is normal to the wall along the negative  $x$ -direction. By Newton's third law, the force on wall due to the ball is normal to the wall along the positive  $x$ -direction.

**EXAMPLE 17.** An elevator weighs 4000 kg. When the upward tension in the supporting cable is 48000 N, what is the upward acceleration ? Starting from rest, how far does it rise in 3 s ?

**Solution.** Mass of elevator,  $M = 4000$  kg

Weight of elevator

$$= Mg = 4000 \text{ kg wt} = 4000 \times 9.8 = 39200 \text{ N}$$

Upward tension,  $T = 48000$  N

Net upward force on the elevator,

$$F' = T - Mg = 48000 - 39200 = 8800 \text{ N}$$

$$\text{Upward acceleration, } a = \frac{F'}{m} = \frac{8800}{4000} = 2.2 \text{ ms}^{-2}$$

For upward motion :  $u = 0$ ,  $a = 2.2 \text{ ms}^{-2}$ ,  $t = 3$  s

$$\therefore s = ut + \frac{1}{2}at^2 = 0 \times 3 + \frac{1}{2} \times 2.2 \times 3^2 = 9.9 \text{ m.}$$

**EXAMPLE 18.** A lift of mass 2000 kg is supported by thick steel ropes. If maximum upward acceleration of the lift be  $1.2 \text{ ms}^{-2}$ , and the breaking stress for the ropes be  $2.8 \times 10^8 \text{ Nm}^{-2}$ , what should be the minimum diameter of rope ?

**Solution.** Here  $m = 2000$  kg,  $a = 1.2 \text{ ms}^{-2}$ ,

$$\text{breaking stress} = 2.8 \times 10^8 \text{ Nm}^{-2}.$$

As the lift moves upwards, so the tension in the rope is

$$T = m(g + a) = 2000(9.8 + 1.2) = 22,000 \text{ N.}$$

$$\text{Now, breaking stress} = \frac{\text{Force}}{\text{Area}} = \frac{T}{\pi D^2 / 4} = \frac{4T}{\pi D^2}$$

$$\text{or } 2.8 \times 10^8 = \frac{4 \times 22,000 \times 7}{22 \times D^2}$$

$$\text{or } D^2 = \frac{4 \times 22,000 \times 7}{22 \times 2.8 \times 10^8} = 10^{-4}$$

$$\text{or } D = 10^{-2} \text{ m} = 1 \text{ cm.}$$

### ✖ PROBLEMS FOR PRACTICE

- An elevator weighing 5000 kg is moving upward and tension in the supporting cable is 50,000 N. Find the upward acceleration. How far does it rise in a time of 10 seconds starting from rest ?  
(Ans.  $0.2 \text{ ms}^{-2}$ , 10 m)
- A woman weighing 50 kgf stands on a weighing machine placed in a lift. What will be the reading of the machine, when the lift is (i) moving upwards with a uniform velocity of  $5 \text{ ms}^{-1}$  and (ii) moving downwards with a uniform acceleration of  $1 \text{ ms}^{-2}$  ? Take  $g = 10 \text{ ms}^{-2}$ . [Punjab 91]  
(Ans. (i) 500 N (ii) 450 N)
- A 75 kg man stands in a lift. What force does the floor exert on him when the elevator starts moving upwards with an acceleration of  $2.0 \text{ ms}^{-2}$  ? Take  $g = 10 \text{ ms}^{-2}$ . (Ans. 90 kg f)
- Find the apparent weight of a man weighing 49 kg on earth when he is standing in a lift which is (i) rising with an acceleration of  $1.2 \text{ ms}^{-2}$  (ii) going down with the same acceleration (iii) falling freely

under the action of gravity and (iv) going up or down with uniform velocity. Given  $g = 9.8 \text{ ms}^{-2}$ .

[Ans. (i) 55 kg f (ii) 43 kg f (iii) 0 (iv) 49 kg f]

- A body of mass 15 kg is hung by a spring balance in a lift. What would be the reading of the balance when (i) the lift is ascending with an acceleration of  $2 \text{ ms}^{-2}$  (ii) descending with the same acceleration (iii) descending with a constant velocity of  $2 \text{ ms}^{-1}$  ? Take  $g = 10 \text{ ms}^{-2}$ .  
(Ans. (i) 18 kg f (ii) 12 kg f (iii) 15 kg f)
- A mass of 10 kg is suspended from a string, the other end of which is held in hand. Find the tension in the string when the hand is moved up with a uniform acceleration of  $2 \text{ ms}^{-2}$ . Given  $g = 10 \text{ ms}^{-2}$ . (Ans. 120 N)
- The strings of a parachute can bear a maximum tension of 72 kg wt. By what minimum acceleration can a person of 96 kg descend by means of this parachute ? (Ans.  $2.45 \text{ ms}^{-2}$ )
- A 70 kg man in sea is being lifted by a helicopter with the help of a rope which can bear a maximum tension of 100 kg wt. With what maximum acceleration the helicopter should rise so that the rope may not break ? Given  $g = 9.8 \text{ ms}^{-2}$ . (Ans.  $4.2 \text{ ms}^{-2}$ )
- An elevator and its load weigh a total of 800 kg. Find the tension  $T$  in the supporting cable when the elevator, originally moving downwards at  $20 \text{ ms}^{-1}$  is brought to rest with constant retardation in a distance of 50 m. (Ans.  $1.014 \times 10^4$  N)

### ✖ HINTS

- Use  $T - mg = ma$
- $R = m(g + a) = 75(10 + 2) \text{ N} = 900 \text{ N} = 90 \text{ kg f.}$
- (i)  $R = m(g + a) = 49(1.2 + 9.8) = 49 \times 11 \text{ N}$   
 $= \frac{49 \times 11}{9.8} = 55 \text{ kg f.}$   
(ii)  $R = m(g - a) = 49(9.8 - 1.2) \text{ N} = 43 \text{ kg f.}$   
(iii)  $R = m(g - g) = 0.$   
(iv)  $R = m(g - 0) = mg = 49 \text{ kg f.}$
- (i)  $R = m(g + a) = 15(10 + 2) = 180 \text{ N} = 18 \text{ kg f.}$   
(ii)  $R = m(g - a) = 15(10 - 2) = 120 \text{ N} = 12 \text{ kg f.}$   
(iii) Here  $a = 0 \therefore R = mg = 15 \text{ kg f.}$
- For the person to descend,  $T = m(g - a)$   
 $\therefore 72 \times 9.8 = 96(9.8 - a)$  or  $a = 2.45 \text{ ms}^{-2}.$
- For the rising helicopter,  $T = m(g + a)$   
 $\therefore 100 \times 9.8 = 70(9.8 + a)$  or  $a = 4.2 \text{ ms}^{-2}.$
- Here  $m = 800$  kg,  $u = 20 \text{ ms}^{-1}$ ,  $v = 0$ ,  $s = 50$  m,  $T = ?$   
As  $v^2 - u^2 = 2as \therefore 0^2 - (20)^2 = 2a \times 50$   
or  $a = -4 \text{ ms}^{-2}$   
For the elevator moving downwards,  
 $T = m(g - a) = 800(9.8 + 4) = 1.104 \times 10^4 \text{ N.}$

**5.17 CONSERVATION OF LINEAR MOMENTUM**

**38.** State the law of conservation of linear momentum and derive it from Newton's second law of motion.

**Law of conservation of linear momentum.** The second and third laws of motion lead to one of the most important and fundamental principles of physics, called the **law of conservation of linear momentum**. It can be stated as follows :

When no external force acts on a system of several interacting particles, the total linear momentum of the system is conserved. The total linear momentum is the vector sum of the linear momenta of all the particles of the system.

**Derivation of the law of conservation of linear momentum from Newton's second law of motion.** Consider an isolated system (the system on which no external force acts) of  $n$  particles. Suppose the  $n$  particles have masses  $m_1, m_2, m_3, \dots, m_n$  and are moving with velocities  $\vec{v}_1, \vec{v}_2, \vec{v}_3, \dots, \vec{v}_n$ , respectively. Then total linear momentum of the system is

$$\vec{p} = m_1 \vec{v}_1 + m_2 \vec{v}_2 + m_3 \vec{v}_3 + \dots + m_n \vec{v}_n$$

$$= \vec{p}_1 + \vec{p}_2 + \vec{p}_3 + \dots + \vec{p}_n$$

If  $\vec{F}$  is the external force acting on the system, then according to Newton's second law,

$$\vec{F} = \frac{d\vec{p}}{dt}$$

For an isolated system,

$$\vec{F} = 0 \quad \text{or} \quad \frac{d\vec{p}}{dt} = 0$$

As the derivative of a constant is zero, so

$$\vec{p} = \text{constant}$$

$$\text{or} \quad \vec{p}_1 + \vec{p}_2 + \vec{p}_3 + \dots + \vec{p}_n = \text{constant}$$

Thus in the absence of any external force, the total linear momentum of the system is constant. This is the law of conservation of linear momentum.

**39.** Derive the law of conservation of linear momentum from Newton's third law of motion.

**Derivation of the law of conservation of linear momentum from Newton's third law.** As shown in Fig. 5.20, consider two bodies A and B of masses  $m_1$  and  $m_2$  moving in the same direction along a straight line with velocities  $u_1$  and  $u_2$  respectively ( $u_1 > u_2$ ). They collide for time  $\Delta t$ . After collision, let their velocities be  $v_1$  and  $v_2$ .

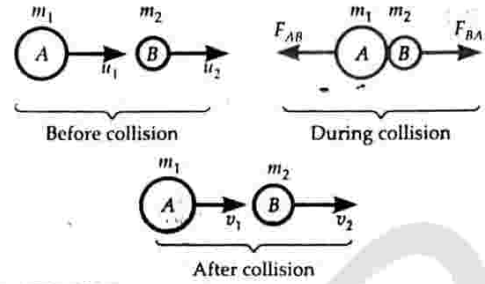

**Fig. 5.20**

During collision, the body A exerts a force  $\vec{F}_{BA}$  on body B. From Newton's third law, the body B also exerts a force  $\vec{F}_{AB}$  on body A such that

$$\vec{F}_{AB} = -\vec{F}_{BA}$$

Impulse of  $\vec{F}_{AB} = \vec{F}_{AB} \Delta t = \text{change in momentum of A}$   
 $= m_1 \vec{v}_1 - m_1 \vec{u}_1$

Impulse of  $\vec{F}_{BA} = \vec{F}_{BA} \Delta t = \text{change in momentum of B}$   
 $= m_2 \vec{v}_2 - m_2 \vec{u}_2$

But  $\vec{F}_{AB} \Delta t = -\vec{F}_{BA} \Delta t$

$$\therefore m_1 \vec{v}_1 - m_1 \vec{u}_1 = -(m_2 \vec{v}_2 - m_2 \vec{u}_2)$$

or  $m_1 \vec{v}_1 + m_2 \vec{v}_2 = m_1 \vec{u}_1 + m_2 \vec{u}_2$

i.e., Total linear momentum = Total linear momentum after collision before collision

This proves the law of conservation of linear momentum.

**40.** Derive Newton's third law of motion from the law of conservation of momentum.

**Derivation of Newton's third law of motion from the law of conservation of momentum.** Consider two bodies of masses  $m_1$  and  $m_2$  moving along a straight line and colliding against each other. The velocities and hence momenta of the two bodies undergo a change. Let  $\Delta p_1$  and  $\Delta p_2$  be the changes in the momenta produced in time  $\Delta t$ .

According to the law of conservation of momentum, the net change in the linear momentum in the absence of external force is zero.

$$\therefore \Delta p_1 + \Delta p_2 = 0$$

or  $\Delta p_2 = -\Delta p_1 \quad \text{or} \quad \frac{\Delta p_2}{\Delta t} = -\frac{\Delta p_1}{\Delta t}$

or Rate of change of momentum of  $m_2$   
 $= -\text{Rate of change of momentum of } m_1$

or Force on  $m_2 = -\text{Force on } m_1$

or Action = - Reaction

This proves the Newton's third law of motion.

**5.18 PRACTICAL APPLICATIONS OF THE LAW OF CONSERVATION OF MOMENTUM**

41. Give some examples from daily life which illustrate the law of conservation of linear momentum.

Practical applications based on the law of conservation of linear momentum :

(i) *Recoil of a gun.* Let 'M' be the mass of the gun and 'm' be the mass of the bullet. Before firing, both the gun and the bullet are at rest. After firing, the bullet moves with velocity  $\vec{v}$  and the gun moves with velocity  $\vec{V}$ . As no external force acts on the system, so according to the principle of conservation of momentum,

$$\begin{aligned} \text{Total momentum before firing} \\ = \text{Total momentum after firing} \end{aligned}$$

or  $0 = m\vec{v} + M\vec{V}$

or  $M\vec{V} = -m\vec{v}$

or  $\vec{V} = -\frac{m}{M}\vec{v}$

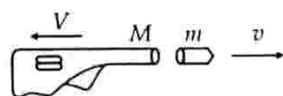

Fig. 5.21

The negative sign shows that  $\vec{V}$  and  $\vec{v}$  are in opposite directions i.e., the gun gives a kick in the backward direction or the gun recoils with velocity  $\vec{V}$ . Further, as  $M \gg m$ , so  $V \ll v$  i.e., the recoil velocity of the gun is much smaller than the forward velocity of the bullet.

(ii) *While firing a bullet, the gun should be held tight to the shoulder.* The recoiling gun can hurt the shoulder. If the gun is held tightly against the shoulder, then the body and the gun together will constitute one system. Total mass becomes large and the recoil velocity becomes small.

(iii) *When a man jumps out of a boat to the shore, the boat slightly moves away from the shore.* Initially, the total momentum of the boat and the man is zero. As the man jumps from the boat to the shore, he gains a momentum in the forward direction. To conserve momentum, the boat also gains an equal momentum in the opposite direction. So the boat slightly moves backwards.

(iv) *An astronaut in open space, who wants to return to the spaceship, throws some object in a direction opposite to the direction of motion of the spaceship.* By doing so, he gains a momentum equal and opposite to that of the thrown object and so he moves towards the spaceship.

(v) *Rocket and jetplanes work on the principle of conservation of momentum.* Initially, both the rocket and its fuel are at rest. Their total momentum is zero. For rocket propulsion, the fuel is exploded. The burnt gases are allowed to escape through a nozzle with a very

high downward velocity. The gases carry a large momentum in the downward direction. To conserve momentum, the rocket also acquires an equal momentum in the upward direction and hence starts moving upwards.

(vi) *Explosion of a bomb.* Before explosion, suppose the bomb is at rest. Its total momentum is zero. As it explodes, it breaks up into many parts of masses  $m_1, m_2, m_3$ , etc., which fly off in different directions with velocities  $\vec{v}_1, \vec{v}_2, \vec{v}_3$ , etc.

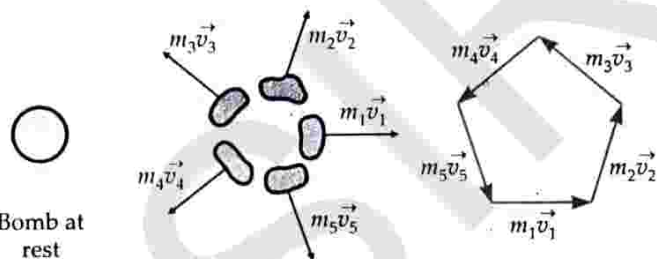

Fig. 5.22 An exploding bomb,  $\sum m\vec{v} = 0$

The different parts have definite momenta  $m_1\vec{v}_1, m_2\vec{v}_2, m_3\vec{v}_3$ , etc.

The momenta of the various parts can be represented by the sides of a closed polygon taken in the same order. This indicates that the total momentum after explosion is zero i.e., momentum is conserved. If bomb explodes into two parts, they will fly off in opposite directions with equal momenta.

**Examples based on Conservation of Linear Momentum**

**FORMULAE USED**

1. In the absence of any external force, vector sum of the linear momenta of a system of particles remains constant.

$$m_1\vec{v}_1 + m_2\vec{v}_2 + m_3\vec{v}_3 + \dots + m_n\vec{v}_n = \text{constant}$$

2. For a two body system,  $m_1u_1 + m_2u_2 = m_1v_1 + m_2v_2$

3. Recoil velocity of a gun,  $V = -\frac{mv}{M}$

where M is the mass of the gun, m the mass of bullet and v is the velocity of the bullet.

**UNITS USED**

All masses are in kg, velocities in  $\text{ms}^{-1}$  and linear momenta in  $\text{kg ms}^{-1}$ .

**EXAMPLE 19.** A 30 kg shell is flying at  $48 \text{ ms}^{-1}$ . When it explodes, its one part of 18 kg stops, while the remaining part flies on. Find the velocity of the later.

**Solution.** Mass of shell,  $M = 30 \text{ kg}$ .

Velocity of shell,  $u = 48 \text{ ms}^{-1}$

After explosion, mass of first part,

$$m_1 = 18 \text{ kg}$$

Velocity of first part,

$$v_1 = 0$$

Mass of second part,

$$m_2 = 30 - 18 = 12 \text{ kg}$$

If  $v_2$  is the velocity of second part, then from the law of conservation of momentum,

$$Mu = m_1 v_1 + m_2 v_2$$

$$\text{or } 30 \times 48 = 18 \times 0 + 12 \times v_2$$

$$\text{or } v_2 = \frac{30 \times 48}{12} = 120 \text{ ms}^{-1}.$$

**EXAMPLE 22.** A neutron having a mass  $1.67 \times 10^{-27}$  kg and moving at  $10^8 \text{ ms}^{-1}$  collides with a deuteron at rest and sticks to it. If the mass of deuteron is  $3.34 \times 10^{-27}$  kg, find the speed of the combination.

**Solution.** For neutron :

$$m_1 = 1.67 \times 10^{-27} \text{ kg}, u_1 = 10^8 \text{ ms}^{-1}$$

For deuteron :

$$m_2 = 3.34 \times 10^{-27} \text{ kg}, u_2 = 0$$

Let  $v$  be the speed of the combination. Then by conservation of momentum,

$$m_1 u_1 + m_2 u_2 = (m_1 + m_2) v$$

$$1.67 \times 10^{-27} \times 10^8 + 3.34 \times 10^{-27} \times 0 \\ = (1.67 + 3.34) \times 10^{-27} \times v$$

$$\text{or } v = \frac{1.67 \times 10^{-27} \times 10^8}{5.01 \times 10^{-27}} = 0.333 \times 10^8 \text{ ms}^{-1}.$$

**EXAMPLE 23.** A car of mass 1000 kg travelling at  $32 \text{ ms}^{-1}$  dashes into the rear of a truck of mass 8000 kg moving in the same direction with a velocity of  $4 \text{ ms}^{-1}$ . After the collision, the car bounces with a velocity of  $8 \text{ ms}^{-1}$ . What is the velocity of truck after the impact ?

**Solution.** For the car :

$$m_1 = 1000 \text{ kg}, u_1 = 32 \text{ ms}^{-1}, v_1 = -8 \text{ ms}^{-1}$$

$$\text{For the truck : } m_2 = 8000 \text{ kg}, u_2 = 4 \text{ ms}^{-1}, v_2 = ?$$

By conservation of linear momentum,

$$m_1 u_1 + m_2 u_2 = m_1 v_1 + m_2 v_2$$

$$1000 \times 32 + 8000 \times 4 = 1000 \times (-8) + 8000 v_2$$

$$\text{or } 64000 + 8000 = 8000 v_2$$

$$\text{or } v_2 = \frac{72000}{8000} = 9 \text{ ms}^{-1}.$$

(in the same direction)

**EXAMPLE 22.** A hunter has a machine gun that can fire 50 g bullets with a velocity of  $150 \text{ ms}^{-1}$ . A 60 kg tiger springs at him with a velocity of  $10 \text{ ms}^{-1}$ . How many bullets must the hunter fire into the tiger in order to stop him in track ?

**Solution.** Mass of bullet,  $m = 50 \text{ g} = 0.05 \text{ kg}$

Velocity of bullet,  $v = 150 \text{ ms}^{-1}$

Mass of tiger,  $M = 60 \text{ kg}$

Velocity of tiger,  $V = 10 \text{ ms}^{-1}$

Let  $n$  be the number of bullets required to be pumped into the tiger to stop him in his track.

According to the law of conservation of momentum,

Magnitude of the momentum of  $n$  bullets

$$= \text{Magnitude of the momentum of tiger}$$

$$\text{or } n \times mv = MV \quad \text{or } n = \frac{MV}{mv} = \frac{60 \times 10}{0.05 \times 150} = 80.$$

**EXAMPLE 23.** A body of mass 1 kg initially at rest explodes and breaks into three fragments of masses in the ratio 1:1:3. The two pieces of equal mass fly off perpendicular to each other with a speed of  $30 \text{ ms}^{-1}$  each. What is the velocity of the heavier fragment ?

[IIT 82]

**Solution.** Here  $m_1 + m_2 + m_3 = 1 \text{ kg}$

As  $m_1 : m_2 : m_3 = 1 : 1 : 3$

$$\therefore m_1 = m_2 = 0.2 \text{ kg}, m_3 = 0.6 \text{ kg}$$

$$v_1 = v_2 = 30 \text{ ms}^{-1}, v_3 = ?$$

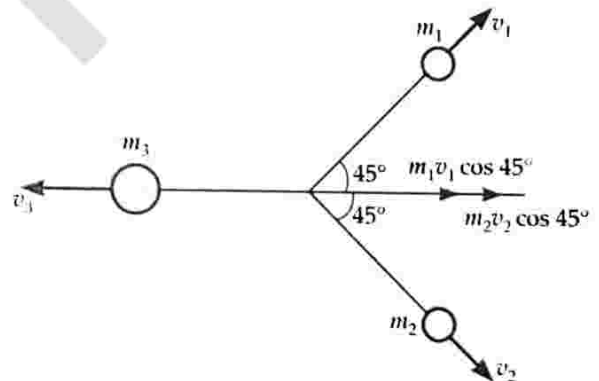

**Fig. 5.23**

Applying the law of conservation of momentum to the momenta along horizontal direction,

$$m_3 v_3 = m_1 v_1 \cos 45^\circ + m_2 v_2 \cos 45^\circ$$

$$0.6 v_3 = 0.2 \times 30 \times 0.707 + 0.2 \times 30 \times 0.707$$

$$\text{or } v_3 = \frac{2 \times 0.2 \times 30 \times 0.707}{0.6} = 14.14 \text{ ms}^{-1}.$$

**EXAMPLE 24.** A disc of mass 10 g is kept floating horizontally by throwing 10 marbles per second against it from below. If the mass of each marble is 5 g, calculate the velocity with which the marbles are striking the disc. Assume that the marbles strike the disc normally and rebound downward with the same speed.

[IIT]

**Solution.** Mass of each marble piece,

$$m = 5 \text{ g} = 5 \times 10^{-3} \text{ kg}$$

Number of marbles thrown per second = 10

Let velocity of impact of each marble =  $v$

Change in momentum of each marble

$$= mv - (-mv) = 2mv$$

Change in momentum per second =  $2mv \times 10$

$\therefore$  Force exerted by marbles on the disc =  $20mv$

But the disc can be kept floating if this force balances the weight of the disc.

$$\therefore 20mv = Mg$$

$$20 \times 5 \times 10^{-3} \times v = 10 \times 10^{-3} \times 9.8$$

$$v = \frac{10 \times 9.8}{100}$$

$$= 0.98 \text{ ms}^{-1} = 98 \text{ cms}^{-1}$$

### X PROBLEMS FOR PRACTICE

1. A 30 g bullet leaves a rifle with a velocity of  $300 \text{ ms}^{-1}$  and the rifle recoils with a velocity of  $0.60 \text{ ms}^{-1}$ . Find the mass of the rifle. (Ans. 15 kg)
2. A 40 kg shell is flying at a speed of  $72 \text{ kmh}^{-1}$ . It explodes into two pieces. One of the two pieces of mass 15 kg stops. Calculate the speed of the other. [Delhi 06] (Ans.  $32 \text{ ms}^{-1}$ )
3. A gun weighing 10 kg fires a bullet of 30 g with a velocity of  $330 \text{ ms}^{-1}$ . With what velocity does the gun recoil? What is the combined momentum of the gun and bullet before firing and after firing? (Ans.  $99 \text{ cms}^{-1}$ , zero before and after firing)
4. A car of mass 1000 kg moving with a speed of 30 m/s collides with the back of a stationary lorry of mass 9000 kg. Calculate the speed of the vehicles immediately after the collision if they remain jammed together. [Central Schools 08] (Ans.  $3 \text{ ms}^{-1}$ )
5. A bullet of mass 7 g is fired into a block of metal weighing 7 kg. The block is free to move. After the impact, the velocity of the bullet and the block is  $70 \text{ ms}^{-1}$ . What is the initial velocity of the bullet? (Ans.  $700.7 \text{ ms}^{-1}$ )
6. A truck of mass  $2 \times 10^4 \text{ kg}$  travelling at  $0.5 \text{ ms}^{-1}$  collides with another truck of half its mass moving in the opposite direction with a velocity of  $0.4 \text{ ms}^{-1}$ . If the trucks couple automatically on collision, calculate the common velocity with which they move. (Ans.  $0.2 \text{ ms}^{-1}$ )
7. A neutron of mass  $1.67 \times 10^{-27} \text{ kg}$  moving with a speed of  $3 \times 10^6 \text{ ms}^{-1}$  collides with a deuteron of mass  $3.34 \times 10^{-27} \text{ kg}$  which is at rest. After collision, the neutron sticks to the deuteron and forms a triton. What is the speed of the triton? (Ans.  $10^6 \text{ ms}^{-1}$ )

8. A bomb at rest explodes into three fragments of equal masses. Two fragments fly off at right angles to each other with velocities  $9 \text{ ms}^{-1}$  and  $12 \text{ ms}^{-1}$  respectively. Calculate the speed of the third fragment. (Ans.  $15 \text{ ms}^{-1}$ )
9. A man weighing 60 kg runs along the rails with a velocity of  $18 \text{ kmh}^{-1}$  and jumps into a car of mass 1 quintal standing on the rails. Calculate the velocity with which the car will start travelling along the rails. (Ans.  $1.88 \text{ ms}^{-1}$ )
10. A machine gun of mass 10 kg fires 20 g bullets at the rate of 10 bullets per second with a speed of  $500 \text{ ms}^{-1}$ . What force is required to hold the gun in position? (Ans. 100 N)

### X HINTS

2. Proceed as in Example 19.

8. Let  $\vec{p}_1, \vec{p}_2$  and  $\vec{p}_3$  be the momenta and  $\vec{v}_1, \vec{v}_2$  and  $\vec{v}_3$  be the velocities of the three fragments respectively.

$$\text{Then } \vec{p}_1 = m\vec{v}_1, \vec{p}_2 = m\vec{v}_2, \vec{p}_3 = m\vec{v}_3,$$

$$v_1 = 9 \text{ ms}^{-1}, v_2 = 12 \text{ ms}^{-1}, v_3 = ?$$

As  $\vec{p}_1 \perp \vec{p}_2$ , so the magnitude of their resultant is

$$p = \sqrt{p_1^2 + p_2^2} = m\sqrt{v_1^2 + v_2^2}$$

$$= m\sqrt{9^2 + 12^2} = 15m \text{ kg ms}^{-1}$$

By conservation of linear momentum,  $\vec{p} + \vec{p}_3 = 0$

In magnitude,  $p_3 = p$  or  $mv_3 = p$

$$\therefore v_3 = \frac{p}{m} = \frac{15m}{m} = 15 \text{ ms}^{-1}$$

9. Here  $m_1 = 60 \text{ kg}, u_1 = 18 \text{ kmh}^{-1} = 5 \text{ ms}^{-1}$ ,

$$m_2 = 1 \text{ quintal} = 100 \text{ kg}, u_2 = 0, v = ?$$

By conservation of linear momentum,

$$(m_1 + m_2)v = m_1u_1 + m_2u_2$$

$$\text{or } (60 + 100)v = 60 \times 5 + 100 \times 0$$

$$\text{or } v = \frac{60 \times 5}{160} = \frac{15}{8} = 1.88 \text{ ms}^{-1}$$

10. Change in the momentum of one bullet

$$= m(v - u) = 2 \times 10^{-3} (500 - 0) = 10 \text{ kg ms}^{-1}$$

Change in momentum of 10 bullets

$$= 10 \times 10 = 100 \text{ kg ms}^{-1}$$

Force required to hold the gun

$$= \frac{\text{Change in momentum}}{\text{Time taken}} = \frac{100 \text{ kg ms}^{-1}}{1 \text{ s}}$$

$$= 100 \text{ N.}$$

### 5.19 ▽ EXAMPLES OF VARIABLE-MASS SITUATION : ROCKET PROPULSION \*

42. (a) Briefly describe the propulsion of a rocket. (b) Derive the expression for the velocity of a rocket at any time, after being fired. (c) What is meant by burnt out speed of a rocket? (d) Also obtain an expression for the thrust on a rocket.

**Rocket propulsion.** The propulsion of a rocket is an example of momentum conservation. In a rocket, gases at high temperature and pressure, are produced by the combustion of fuel. They escape with a large constant velocity through a nozzle. The large backward momentum of the gases imparts an equal forward momentum to the rocket. But due to the decrease in the mass of the rocket fuel system, the acceleration of the rocket keeps on increasing.

#### Expression for the velocity gained by a rocket.

Suppose at time  $t = 0$ , we have

$m_0$  = initial mass of the rocket including that of the fuel

$v_0$  = initial velocity of the rocket

Suppose at time  $t = t$ , we have

$m$  = mass of the rocket left

$v$  = velocity acquired by the rocket

As the gases are escaping from rocket, we must have

$$m < m_0 \text{ and } v > v_0$$

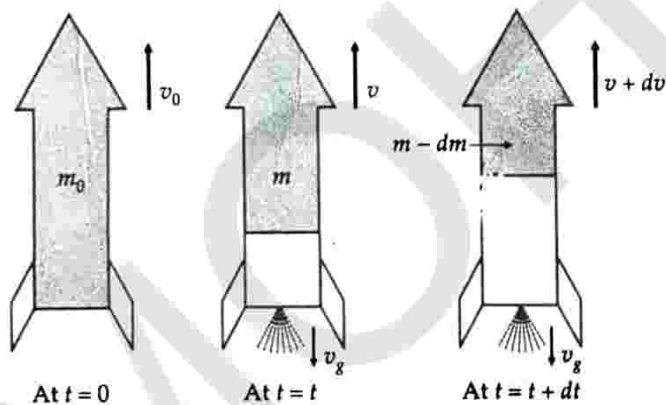

Fig. 5.24 Rocket propulsion.

Suppose in a small interval of time  $dt$ ,

$dm$  = a small decrease in mass of the rocket  
= mass of the exhaust gases that escape

$dv$  = corresponding small increase in velocity of the rocket.

$v_g$  = velocity of exhaust gases w.r.t. the earth

Using the principle of conservation of linear momentum, we get

$$mv = (m - dm)(v + dv) + dm(-v_g) \quad \dots(1)$$

Here  $v_g$  is taken negative because gases escape downwards as the rocket moves upwards.

From (1), we have

$$mv = mv + m(dv) - (dm)v - dm dv - (dm)v_g$$

As  $dm$  and  $dv$  both are small, their product term can be neglected.

$$\therefore m dv = dm(v + v_g) \quad \dots(2)$$

If  $u$  is relative velocity of burnt gases w.r.t. rocket, then

$$u = \text{Velocity of burnt gases w.r.t. the earth} \\ - \text{Velocity of the rocket w.r.t. the earth}$$

$$= -v_g - v = -(v_g + v)$$

$$\text{or } v + v_g = -u$$

The negative sign shows the downward direction of motion of the gases.

$$\therefore m dv = -u dm \quad \dots(3)$$

$$dv = -u \frac{dm}{m}$$

Integrating both sides, we get

$$\int_{v_0}^v dv = -u \int_{m_0}^m \frac{dm}{m}$$

$$[v]_{v_0}^v = -u [\log_e m]_{m_0}^m$$

$$\text{or } v - v_0 = -u [\log_e m - \log_e m_0]$$

$$= -u \log_e \left( \frac{m}{m_0} \right) = +u \log_e \left( \frac{m_0}{m} \right)$$

$$\text{or } v = v_0 + u \log_e \left( \frac{m_0}{m} \right) \quad \dots(4)$$

This gives the velocity of the rocket at any time  $t$ , when its mass is  $m$

At time  $t = 0$ ,  $v_0 = 0$ , so

$$v = u \log_e \left( \frac{m_0}{m} \right) \quad \dots(5)$$

Thus in the absence of any external force, the instantaneous velocity of the rocket is proportional to

- (i) the exhaust speed of the burnt gases.
- (ii) natural logarithm of the ratio of initial mass of the rocket to its mass at the instant.

**Burnt out speed of the rocket.** The speed acquired by the rocket when whole of its fuel gets burnt is called the burnt out speed of the rocket. If  $m_r$  is residual mass of the rocket at that instant, then from equation (4), we get

$$v_b = v_0 + u \log_e \left( \frac{m_0}{m_r} \right)$$

Obviously,  $v_b$  is the maximum velocity that the rocket can acquire.



**Thrust on the rocket.** It is the force with which the rocket moves upwards.

Dividing both sides of equation (3) by small time interval  $dt$ , we get

$$m \frac{dv}{dt} = -u \frac{dm}{dt} \quad \dots(6)$$

As  $dv/dt = a$ , acceleration of the rocket at time  $t$ .

$\therefore m dv/dt = ma = F =$  thrust on the rocket at time  $t$ .

From (6),  $F = -u dm/dt$

Thus the upthrust on a rocket at any instant is equal to the product of the exhaust speed of the burnt gases and the rate of consumption of fuel at that instant.

### Examples Based on Rocket Propulsion

#### FORMULAE USED

1. Resultant force on the rocket

$$F = \text{upthrust on the rocket} - \text{weight of the rocket}$$

$$= u \frac{dm}{dt} - mg$$

2. Acceleration of the rocket after time  $t$

$$a = \left[ \frac{u}{m_0 - t \frac{dm}{dt}} \right] \frac{dm}{dt} - g$$

3. Velocity of the rocket after time  $t$ ,

$$v = v_0 + u \log_e \frac{m_0}{m} - gt$$

If the effect of gravity is neglected, then

$$F = u \frac{dm}{dt}$$

$$a = \left[ \frac{u}{m_0 - t \frac{dm}{dt}} \right] \frac{dm}{dt}; v = v_0 + u \log_e \frac{m_0}{m}$$

4. Burn-out speed of the rocket,

$$v_b = v_0 + u \log_e \frac{m}{m_r}$$

Here :

$u$  = Velocity of exhaust gases

$v_0$  = Initial velocity of the rocket

$v$  = Velocity of the rocket at any instant  $t$

$m_0$  = Initial mass of the rocket

$m$  = Final mass of the rocket

$m_r$  = Mass of the empty rocket

$dm/dt$  = Rate of ejection of fuel

#### UNITS USED

Velocities  $u$ ,  $v_0$ ,  $v$  and  $v_b$  are in  $\text{ms}^{-1}$  and masses  $m_0$ ,  $m$  and  $m_r$  are in kg.

**EXAMPLE 25.** Fuel is consumed at the rate of  $100 \text{ kg s}^{-1}$  in a rocket. The exhaust gases are ejected at speed of  $4.5 \times 10^4 \text{ ms}^{-1}$ . What is thrust experienced by the rocket?

**Solution.** Here

$$\frac{dm}{dt} = 100 \text{ kg s}^{-1}, u = 4.5 \times 10^4 \text{ ms}^{-1}$$

$$\text{Thrust, } F = u \frac{dm}{dt} = 4.5 \times 10^4 \times 100 = 4.5 \times 10^6 \text{ N.}$$

**EXAMPLE 26.** A rocket of initial mass 6,000 kg ejects mass at a constant rate of  $16 \text{ kg s}^{-1}$  with constant relative speed of  $11 \text{ kms}^{-1}$ . What is acceleration of the rocket a minute after the blast? Neglect gravity. [NCERT]

**Solution.** Here  $m_0 = 6,000 \text{ kg}$ ,

$$u = 11 \text{ km s}^{-1} = 11,000 \text{ ms}^{-1},$$

$$t = 1 \text{ min} = 60 \text{ s}, \frac{dm}{dt} = 16 \text{ kgs}^{-1}$$

Acceleration,

$$a = \left[ \frac{u}{m_0 - t \frac{dm}{dt}} \right] \frac{dm}{dt}$$

$$= \left[ \frac{11000}{6000 - 60 \times 16} \right] \times 16 = 34.92 \text{ ms}^{-2}.$$

**EXAMPLE 27.** The mass of a rocket is 500 kg and relative velocity of gases ejecting out is  $250 \text{ ms}^{-1}$  with respect to the rocket. Determine the rate of burning of the fuel in order to give the rocket an initial acceleration of  $20 \text{ ms}^{-2}$  in the upward direction.

**Solution.** Initial acceleration,  $a = \frac{u}{m_0} \frac{dm}{dt} - g$

$$\therefore 20 = \frac{250}{500} \frac{dm}{dt} - 9.8$$

$$\text{or } \frac{dm}{dt} = 2(20 + 9.8) = 59.6 \text{ kgs}^{-1}.$$

**EXAMPLE 28.** A rocket is set for vertical firing. If the exhaust speed is  $1200 \text{ ms}^{-1}$ , how much gas must be ejected per second to supply the thrust needed (i) to overcome the weight of the rocket, (ii) to give to the rocket an initial vertical upward acceleration of  $19.6 \text{ ms}^{-2}$ ? Given mass of rocket = 6000 kg.

**Solution.** (i) Here  $u = 1200 \text{ ms}^{-1}$ ,  $m = 6000 \text{ kg}$ ,

$$\frac{dm}{dt} = ?$$

Given : Thrust = Weight of rocket

$$\therefore u \frac{dm}{dt} = mg$$

$$\text{or } \frac{dm}{dt} = \frac{mg}{u} = \frac{6000 \times 9.8}{1200} = 49 \text{ kg s}^{-1}.$$

(ii) Here  $u = 1200 \text{ ms}^{-1}$ ,  $m = m_0 = 6000 \text{ kg}$ ,  $t = 0$ ,  
 $a = 29.6 \text{ ms}^{-2}$

$$\text{As } a = \left[ \frac{u}{m_0 - t \frac{dm}{dt}} \right] \frac{dm}{dt} - g$$

$$\therefore 29.6 = \left[ \frac{1200}{6000 - 0 \times \frac{dm}{dt}} \right] \frac{dm}{dt} - 9.8$$

$$\text{or } 29.6 + 9.8 = \frac{1200}{6000} \times \frac{dm}{dt}$$

$$\text{or } \frac{dm}{dt} = \frac{39.4 \times 6000}{1200} = 197 \text{ kg s}^{-1}.$$

**EXAMPLE 29.** If the maximum possible exhaust velocity of a rocket be  $2 \text{ kms}^{-1}$ , calculate the ratio  $m_0/m$  for it if it is to acquire the escape velocity of  $11.2 \text{ kms}^{-1}$  after starting from rest.

**Solution.** As the rocket starts from rest, velocity acquired by it is

$$v = u \log_e \frac{m_0}{m} = 2.303 u \log_{10} \frac{m_0}{m}$$

$$\text{Given } v = 11.2 \text{ km s}^{-1}, \quad u = 2 \text{ km s}^{-1}$$

$$\therefore 11.2 = 2.303 \times 2 \times \log_{10} \frac{m_0}{m}$$

$$\text{or } \log_{10} \frac{m_0}{m} = \frac{11.2}{2.303 \times 2} = 2.432$$

$$\text{or } \frac{m_0}{m} = \text{antilog}(2.432) = 270.4$$

**EXAMPLE 30.** A rocket motor consumes 100 kg of fuel per second, exhausting it with a speed of  $5 \times 10^3 \text{ ms}^{-1}$ . (i) What force is exerted on the rocket? (ii) What will be the velocity of the rocket at the instant its mass is reduced  $(1/20)$ th of its initial mass, its initial velocity being zero. Neglect gravity.

**Solution.** Here  $\frac{dm}{dt} = 100 \text{ kg s}^{-1}$ ,

$$u = 5 \times 10^3 \text{ ms}^{-1}, \quad v_0 = 0, \quad \frac{m}{m_0} = \frac{1}{20}$$

$$(i) \text{ Thrust} = u \frac{dm}{dt} = 5 \times 10^3 \times 100 = 5 \times 10^5 \text{ N.}$$

$$\begin{aligned} (ii) v &= v_0 + u \log_e \frac{m_0}{m} = 0 + 5 \times 10^3 \log_e 20 \\ &= 5 \times 10^3 \times 2.303 \log_{10} 20 \\ &= 5 \times 10^3 \times 2.303 \times 1.301 \\ &= 14.98 \times 10^3 \text{ ms}^{-1}. \end{aligned}$$

**EXAMPLE 31.** A balloon with mass  $M$  is descending down with an acceleration  $a$ , where  $a < g$ . What mass  $m$  of its contents must be removed so that it starts moving up with acceleration  $a$ ?

**Solution.** As shown in Fig. 5.25, a retarding force  $F$  acts on the balloon in the vertically upward direction and its weight  $mg$  acts in the vertically downward direction. Net force acting on the balloon in the vertically downward direction

$$= Mg - F$$

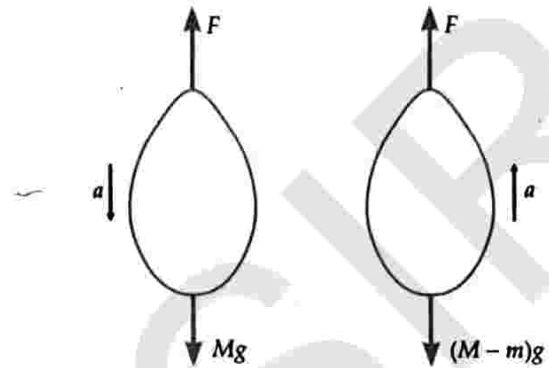

**Fig. 5.25**

As the balloon descends down with acceleration  $a$ ,  
 so  $Mg - F = Ma$  ... (i)

When mass  $m$  is removed from the balloon, its net weight  $= (M - m)g$ .

Now the balloon moves with acceleration  $a$ , therefore

$$F - (M - m)g = (M - m)a$$

$$\text{or } Mg - Ma - (M - m)g = (M - m)a \quad [\text{Using (i)}]$$

$$\text{or } Mg - Ma - Mg + mg = Ma - ma$$

$$\text{or } m(g + a) = 2Ma$$

$$\text{or } m = \frac{2Ma}{g + a}$$

### PROBLEMS FOR PRACTICE

1. A rocket with a lift mass of  $3.5 \times 10^4 \text{ kg}$  is blasted upwards with an acceleration of  $10 \text{ ms}^{-2}$ . Calculate the initial thrust of the blast. [AIEEE 03]  
 (Ans.  $7.0 \times 10^5 \text{ N}$ )
2. Fuel is consumed at the rate of 50 g per second in a rocket. The exhaust gases are rejected at the rate of  $5 \times 10^5 \text{ cms}^{-1}$ . What is the thrust experienced by the rocket? (Ans. 250 N)
3. Calculate the ratio  $m/m_0$  for a rocket to attain the escape velocity of  $11.2 \text{ kms}^{-1}$  after starting from rest, when maximum exhaust velocity of the gases is  $1.6 \text{ kms}^{-1}$ . (Ans. 1096)
4. In the first second of its flight, a rocket ejects  $1/60$  of its mass with a relative velocity of  $2073 \text{ ms}^{-1}$ . What is the initial acceleration of the rocket? (Ans.  $24.75 \text{ ms}^{-2}$ )
5. A rocket motor consumes 100 kg of fuel per second, exhausting it with a speed of  $6 \times 10^3 \text{ ms}^{-1}$ . (i) What

thrust is exerted on the rocket ? (ii) What will be the velocity of the rocket at the instant its mass is reduced to (1/40)th of its initial mass, its initial velocity being zero ? Neglect gravity.

[Ans. (i)  $6 \times 10^5$  N (ii)  $22.13 \times 10^3$  ms<sup>-1</sup>]

6. A rocket fired from the earth's surface ejects 1% of its mass at a speed of 2000 ms<sup>-1</sup> in the first second. Find the average acceleration of the rocket in the first second. (Ans. 20 ms<sup>-2</sup>)
7. A rocket is going upwards with accelerated motion. A man sitting in it feels his weight increased by 5 times his own weight. If the mass of the rocket including that of the man is  $1.0 \times 10^4$  kg, how much force is being applied by rocket engine ? Given  $g = 10$  ms<sup>-2</sup>. (Ans.  $5 \times 10^5$  N)
8. A balloon of mass  $m$  is rising up with an acceleration  $a$ . Show that the fraction of weight of the balloon that must be detached in order to double its acceleration is  $[ma / (2a + g)]$ , assuming the upthrust of air to remain the same.

**HINTS**

$$3. \quad v = u \log_e \frac{m_0}{m} = 2.303 u \log_{10} \frac{m_0}{m}$$

$$\log_{10} \frac{m}{m_0} = \frac{v}{2.303 \times u}$$

$$= \frac{11.2 \text{ kms}^{-1}}{2.303 \times 1.6 \text{ kms}^{-1}} = 3.0400$$

$$\therefore \frac{m}{m_0} = \text{antilog}(3.0400) = 1096.$$

$$4. \quad \text{Acceleration at } t = 0 \text{ is}$$

$$a = \frac{u}{m_0} \frac{dm}{dt} - g = \frac{2073}{m_0} \times \frac{1/m_0}{1} - 9.8$$

$$= 34.55 - 9.8 = 24.75 \text{ ms}^{-2}.$$

$$6. \quad F = u \frac{dm}{dt}$$

Here  $dm = \frac{m_0}{100}$ ,  $dt = 1$  s,  $u = 2000$  ms<sup>-1</sup>

$$\therefore F = 2000 \times \frac{m_0 / 100}{1} = 20 m_0$$

or  $a = \frac{F}{m_0} = 20 \text{ ms}^{-2}.$

$$7. \quad \text{As the weight of man increases by 5 times, so acceleration of the rocket,}$$

$$a = 5g = 5 \times 10 = 50 \text{ ms}^{-2}$$

Force applied by rocket engine is

$$F = ma = 1.0 \times 10^4 \times 50 = 5 \times 10^5 \text{ N.}$$

$$8. \quad \text{Let } F \text{ be the upthrust of the air: As the balloon rises with acceleration } a, \text{ so}$$

$$F = mg + ma \quad \dots(1)$$

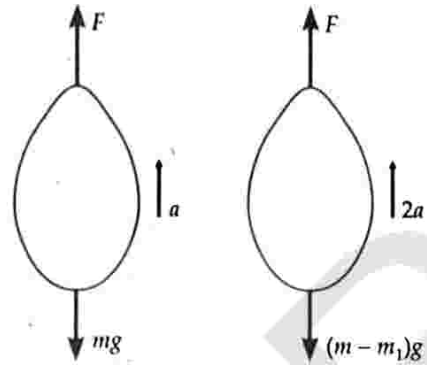

Fig. 5.26

Suppose mass  $m_1$  is removed from the balloon so that the acceleration becomes  $2a$ . Then

$$F = (m - m_1)g + (m - m_1)2a \quad \dots(2)$$

From (1) and (2), we get,

$$(m - m_1)g + (m - m_1)2a = m(g + a)$$

or  $m - m_1 = \frac{m(g + a)}{(g + 2a)}$

or  $m_1 = m - \frac{m(g + a)}{(g + 2a)} = \frac{ma}{g + 2a}.$

**5.20 EQUILIBRIUM OF CONCURRENT FORCES**

43. What are concurrent forces ? Obtain the condition for the equilibrium of a number of concurrent forces.

**Equilibrium of concurrent forces.** Forces acting at the same point on a body are called concurrent forces. When a number of forces act on a body at the same point and the net unbalanced force is zero, the body will continue in its state of rest or of uniform motion along a straight line and is said to be in equilibrium.

Consider three concurrent forces  $\vec{F}_1$ ,  $\vec{F}_2$  and  $\vec{F}_3$  acting at the same point O of a body, as shown in Fig. 5.27(a). By parallelogram law,

$$\text{Resultant of } \vec{F}_1 \text{ and } \vec{F}_2 = \vec{F}_1 + \vec{F}_2$$

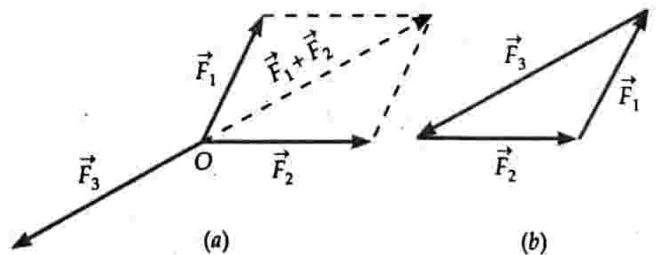

Fig. 5.27 Equilibrium under concurrent forces.

If the third force  $\vec{F}_3$  acts on the body such that  $\vec{F}_3 = -(\vec{F}_1 + \vec{F}_2)$ , then the body will be in equilibrium.

i.e.,  $\vec{F}_3 = -(\vec{F}_1 + \vec{F}_2)$

or  $\vec{F}_1 + \vec{F}_2 + \vec{F}_3 = \vec{0}$

As shown in Fig. 5.27(b), these three forces in equilibrium can be represented by the sides of a triangle taken in the same order.

Thus the condition for the equilibrium of a number of forces acting at the same point is that the vector sum of all these forces is equal to zero.

i.e.,  $\vec{F}_1 + \vec{F}_2 + \vec{F}_3 + \vec{F}_4 + \dots + \vec{F}_n = \vec{0}$

In general, particle is in equilibrium under the action of  $n$  forces if these forces can be represented by the sides of closed  $n$ -side polygon taken in the same order.

**44. State and prove Lami's theorem.**

**Lami's theorem.** Fig. 5.28(a) shows a particle  $O$  under the equilibrium of three concurrent forces  $\vec{F}_1, \vec{F}_2$  and  $\vec{F}_3$ . Let  $\alpha$  be angle between  $\vec{F}_2$  and  $\vec{F}_3$ ,  $\beta$  between  $\vec{F}_3$  and  $\vec{F}_1$ ; and  $\gamma$  between  $\vec{F}_1$  and  $\vec{F}_2$ .

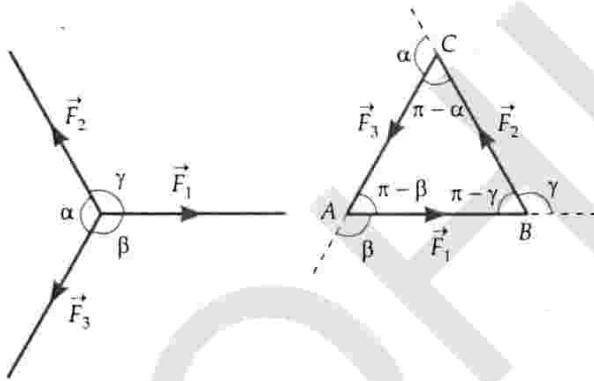

**Fig. 5.28** Lami's theorem

As shown in Fig. 5.28(b), the forces  $\vec{F}_1, \vec{F}_2$  and  $\vec{F}_3$  can be represented by the sides of  $\Delta ABC$ , taken in the same order.

Applying law of sines to  $\Delta ABC$ , we get

$$\frac{F_1}{\sin(\pi - \alpha)} = \frac{F_2}{\sin(\pi - \beta)} = \frac{F_3}{\sin(\pi - \gamma)}$$

or  $\frac{F_1}{\sin \alpha} = \frac{F_2}{\sin \beta} = \frac{F_3}{\sin \gamma}$

This is **Lami's theorem** which states that if three forces acting on a particle keep it in equilibrium, then each force is proportional to the sine of the angle between the other two forces.

**Examples based on Equilibrium of Concurrent Forces**

**FORMULAE USED**

1. A number of forces acting at the same point are called concurrent forces.
2. A number of concurrent forces are said to be in equilibrium if their resultant is zero.

$$\vec{F} = \vec{F}_1 + \vec{F}_2 + \vec{F}_3 + \dots + \vec{F}_n = \vec{0}$$

3. If  $\vec{F}_1, \vec{F}_2$  and  $\vec{F}_3$  are three concurrent forces in equilibrium .

(i)  $\vec{F}_1 + \vec{F}_2 + \vec{F}_3 = \vec{0}$

(ii)  $\frac{F_1}{\sin \alpha} = \frac{F_2}{\sin \beta} = \frac{F_3}{\sin \gamma}$  (Lami's theorem)

**UNITS USED**

All forces are in newton.

**EXAMPLE 32.** A mass of 6 kg is suspended by a rope of length 2 m from a ceiling. A force of 50 N in the horizontal direction is applied at the midpoint of the rope as shown in Fig. 5.29. What is the angle the rope makes with the vertical in equilibrium? Take  $g = 10 \text{ ms}^{-2}$ . Neglect mass of the rope.

[NCERT]

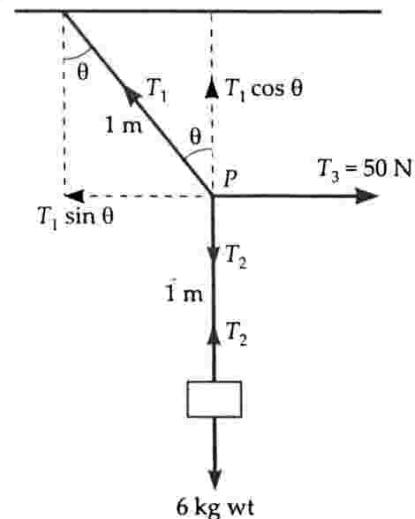

**Fig. 5.29**

**Solution.** As shown in Fig. 5.29, there are three forces acting on the midpoint  $P$  of the rope. Suppose the rope makes an angle  $\theta$  with the vertical in equilibrium. Resolving the forces horizontally and vertically, we get

$$T_1 \sin \theta = T_3 = 50 \text{ N} \quad \dots(i)$$

$$T_1 \cos \theta = T_2 = 6 \text{ kg wt} = 60 \text{ N} \quad \dots(ii)$$

Dividing (i) by (ii), we get,

$$\tan \theta = \frac{5}{6} \text{ or } \theta = \tan^{-1} \left( \frac{5}{6} \right) = 39.8^\circ$$

**EXAMPLE 33.** Determine the tensions  $T_1$  and  $T_2$  in the strings shown in Fig. 5.30(a).

**Solution.** As shown in Fig. 5.30(b), resolve the tension  $T_1$  along horizontal and vertical directions. As the body is in equilibrium,

$$T_1 \sin 60^\circ = 4 \text{ kg wt} = 4 \times 9.8 \text{ N} \quad \dots(i)$$

$$T_1 \cos 60^\circ = T_2 \quad \dots(ii)$$

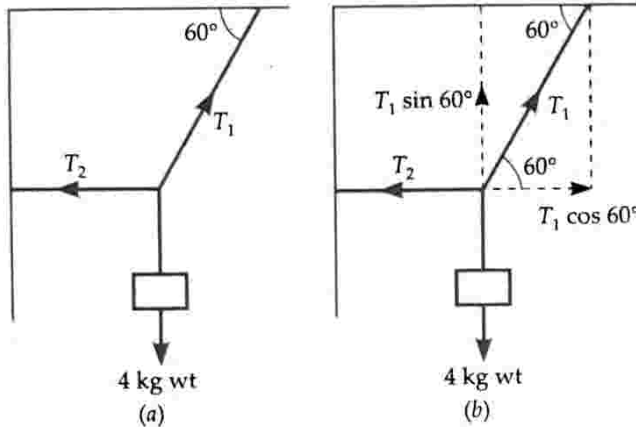

**Fig. 5.30**

From (i),  $T_1 = \frac{4 \times 9.8}{\sin 60^\circ} = \frac{4 \times 9.8 \times 2}{\sqrt{3}} = 45.26 \text{ N}$

From (ii),  $T_2 = T_1 \cos 60^\circ = 45.26 \times 0.5 = 22.63 \text{ N}$ .

**EXAMPLE 34.** A train is moving along a horizontal track. A pendulum suspended from the roof makes an angle of  $4^\circ$  with the vertical. Obtain the acceleration of the train. Take  $g = 10 \text{ ms}^{-2}$ .

**Solution.** Fig. 5.31 shows the equilibrium position of a pendulum suspended in a train which is moving towards right with acceleration  $a$  along a horizontal track.

Two forces acting on the bob are :

- (i) Weight  $mg$  acting vertically downwards,
- (ii) Tension  $T$  acting along the string.

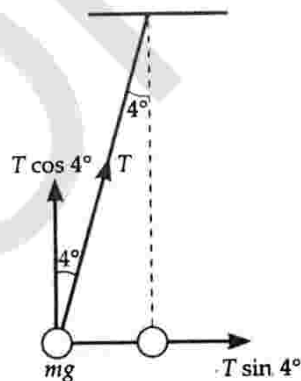

**Fig. 5.31**

Resolving  $T$  along horizontal and vertical directions, we find that

$$T \cos 4^\circ = mg \quad \dots(i)$$

As the acceleration  $a$  of the train and hence that of the pendulum is responsible for tension  $T \sin 4^\circ$ , so

$$T \sin 4^\circ = ma \quad \dots(ii)$$

Dividing (ii) by (i), we get

$$\tan 4^\circ = \frac{a}{g}$$

or  $a = g \tan 4^\circ = 10 \times 0.07 = 0.7 \text{ ms}^{-2}$ .

**EXAMPLE 35.** A ball of mass 1 kg hangs in equilibrium from two strings OA and OB as shown in Fig. 5.32. What are the tensions in strings OA and OB? Take  $g = 10 \text{ ms}^{-2}$ .

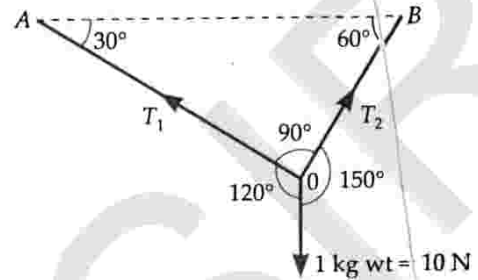

**Fig. 5.32**

**Solution.** Various forces acting at the point O are as shown in Fig. 5.32. The three forces are in equilibrium. Using Lami's theorem,

$$\frac{T_1}{\sin 150^\circ} = \frac{T_2}{\sin 120^\circ} = \frac{10}{\sin 90^\circ}$$

or  $\frac{T_1}{\sin 30^\circ} = \frac{T_2}{\sin 60^\circ} = 1$

$\therefore T_1 = 10 \sin 30^\circ = 10 \times 0.5 = 5 \text{ N}$ .

and  $T_2 = 10 \sin 60^\circ = 10 \times \frac{\sqrt{3}}{2} = 5\sqrt{3} \text{ N}$ .

**EXAMPLE 36.** A body of mass  $m$  is suspended by two strings making angles  $\alpha$  and  $\beta$  with the horizontal as shown in Fig. 5.33. Find the tensions in the strings.

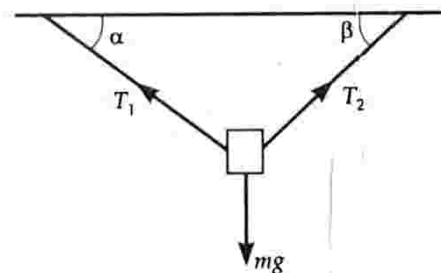

**Fig. 5.33**

**Solution.** The free-body diagram is shown in Fig. 5.34. As the body is in equilibrium, the various forces must add to zero. Taking horizontal components,

$$T_1 \cos \alpha = T_2 \cos \beta \quad \text{or} \quad T_2 = T_1 \frac{\cos \alpha}{\cos \beta}$$

Taking vertical components,

$$T_1 \sin \alpha + T_2 \sin \beta = mg$$

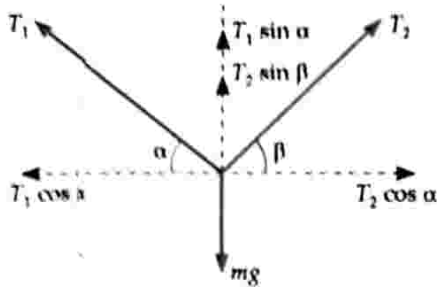

Fig. 5.34

or  $T_1 \sin \alpha + T_2 \sin \beta = mg$

or  $T_1 = \frac{mg}{\sin \alpha + \frac{\cos \alpha}{\sin \beta}} = \frac{mg \cos \beta}{\sin \alpha \cos \beta + \cos \alpha \sin \beta}$

or  $T_1 = \frac{mg \cos \beta}{\sin(\alpha + \beta)}$

and  $T_2 = T_1 \frac{\cos \alpha}{\cos \beta} = \frac{mg \cos \beta}{\sin(\alpha + \beta)} \cdot \frac{\cos \alpha}{\cos \beta} = \frac{mg \cos \alpha}{\sin(\alpha + \beta)}$

**EXAMPLE 37.** A uniform rope of length  $L$ , resting on a frictionless horizontal surface is pulled at one end by a force  $F$ . What is the tension in the rope at a distance  $l$  from the end where the force is applied?

**Solution.** Let  $M$  be the mass of uniform rope of length  $L$ . Then

Mass per unit length of rope  $= \frac{M}{L}$

Acceleration in the rope  $= \frac{F}{M}$

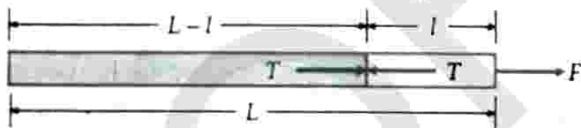

Fig. 5.35

Let  $T$  be the tension in the rope at a distance  $l$  from the end where the force  $F$  is applied.

Mass of length  $(L - l)$  of the rope is

$$M' = \frac{M}{L} (L - l)$$

As tension  $T$  is the only force on the length  $(L - l)$  of the rope, so

$$T = M' \times \frac{F}{M} = \frac{M}{L} (L - l) \times \frac{F}{M} = \left(1 - \frac{l}{L}\right) F.$$

**\* PROBLEMS FOR PRACTICE**

1. A mass of 10 kg is suspended vertically by a rope of length 2 m from a ceiling. A force of 60 N is applied at the middle point of the rope in the horizontal

direction, as shown in Fig. 5.36. Calculate the angle the rope makes with the vertical. Neglect the mass of the rope and take  $g = 10 \text{ ms}^{-2}$ . (Ans.  $31^\circ$ )

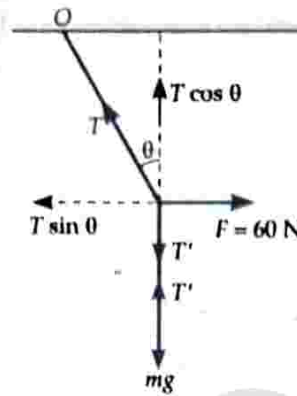

Fig. 5.36

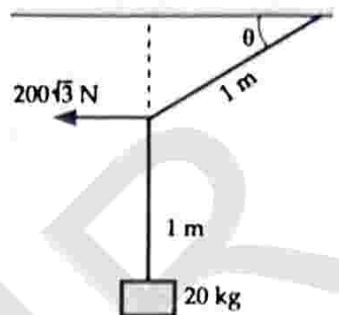

Fig. 5.37

2. A mass of 20 kg is suspended by a rope of length 2 m from a ceiling. A force of 173.2 N in the horizontal direction is applied at the midpoint of the rope as shown in Fig. 5.37. What is the angle the rope makes with the horizontal in equilibrium? Take  $g = 10 \text{ ms}^{-2}$ . Neglect mass of the rope. (Ans.  $30^\circ$ )
3. A body of weight 200 N is suspended with the help of strings as shown in Fig 5.38. Find the tensions  $T_1$  and  $T_2$ . (Ans.  $T_1 = 146.4 \text{ N}$ ,  $T_2 = 179.3 \text{ N}$ )

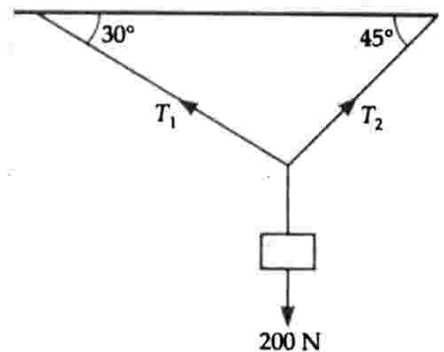

Fig. 5.38

**\* HINTS**

1. For equilibrium of the body,

$$T \sin \theta = F = 60 \text{ N} \quad \dots(i)$$

$$T \cos \theta = T' = mg \quad \dots(ii)$$

Dividing (i) by (ii), we get

$$\frac{T \sin \theta}{T \cos \theta} = \frac{60}{mg} = \frac{60}{10 \times 10} = 0.6$$

or  $\tan \theta = 0.6 \therefore \theta = 31^\circ$ .

3. The free-body diagram is shown in Fig. 5.39.

Resolution of forces along horizontal direction gives

$$T_1 \cos 30^\circ = T_2 \cos 45^\circ$$

$$T_1 \times \frac{\sqrt{3}}{2} = T_2 \times \frac{1}{\sqrt{2}} \text{ or } T_2 = \sqrt{\frac{3}{2}} T_1$$

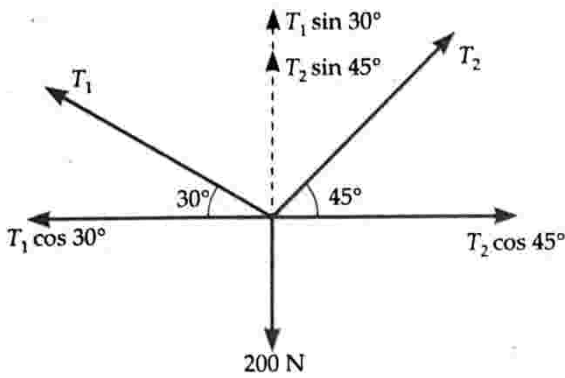

Fig. 5.39

Resolution of forces along vertical direction gives

$$T_1 \sin 30^\circ + T_2 \sin 45^\circ = 200 \text{ N}$$

$$T_1 \times \frac{1}{2} + \sqrt{\frac{3}{2}} T_1 \times \frac{1}{\sqrt{2}} = 200$$

or  $T_1 (1 + \sqrt{3}) = 400$

$$T_1 = \frac{400}{2.732} = 146.4 \text{ N};$$

$$T_2 = \sqrt{\frac{3}{2}} \times 146.4 = 179.3 \text{ N}.$$

Dividing (i) by (ii), we get

$$\frac{Ma}{ma} = \frac{Mg - T}{T - mg} \quad \text{or} \quad \frac{M}{m} = \frac{Mg - T}{T - mg}$$

or  $MT - Mmg = Mmg - mT$

or  $T(M + m) = 2Mmg$

or  $T = \frac{2Mm}{M + m} g.$

46. What is meant by a free-body diagram? What is its use?

**Solving problems in mechanics: Use of free-body diagram.** When a number of bodies are connected together by strings, rods, etc, it is convenient to consider each body separately and to write equation of motion for each body by taking into account all the forces acting on it and then equating the net force acting on the body to its mass times the acceleration produced.

A diagram for each body of the system showing all the forces exerted on the body by the remaining parts of the system is called free-body diagram.

The equations of motion obtained for different bodies can be solved to determine unknown quantities.

5.21 MOTION OF CONNECTED BODIES

45. Two masses  $M$  and  $m$  are connected at the two ends of an inextensible string. The string passes over a smooth frictionless pulley. Calculate the acceleration of the masses and the tension in the string. Given  $M > m$ .

**Connected motion.** Let  $a$  be the acceleration with which the heavier mass  $M$  moves downwards and the lighter mass  $m$  moves upwards. Let  $T$  be the tension in the string. According to Newton's second law, the resultant downward force on mass  $M$  is

$$Ma = Mg - T \quad \dots(i)$$

Resultant upward force on mass  $m$  is

$$ma = T - mg \quad \dots(ii)$$

Adding equations (i) and (ii), we get

$$a(M + m) = (M - m)g$$

or  $a = \frac{M - m}{M + m} \cdot g$

Obviously,  $a < g$  i.e., the acceleration  $a$  of the two connected bodies is less than the acceleration due to gravity.

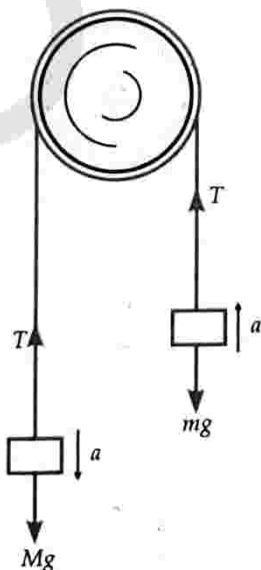

Fig. 5.40

Examples based on Motion of Connected Bodies

CONCEPTS USED

1. When a number of bodies are connected together by strings, rods, etc., it is convenient to draw a free body diagram for each body separately by showing all the forces acting on it.
2. Equation of motion for each body is written by equating the net force acting on the body to its mass times the acceleration produced.

Units Used

All forces are in newton (N)

**EXAMPLE 38.** A pull of 15 N is applied to a rope attached to a block of mass 7 kg lying on a smooth horizontal surface. The mass of the rope is 0.5 kg. What is the force exerted by the block on the rope?

**Solution.** The situation is shown in Fig. 5.41. If acceleration  $a$  is produced in the block on applying a force of 15 N, then

$$(7 + 0.5)a = 15 \quad \text{or} \quad a = \frac{15}{7.5} = 2 \text{ ms}^{-2}$$



Fig. 5.41

As shown in Fig. 5.42, let  $F_2$  be the force exerted by the block on the rope and  $F_2'$  be reaction of the rope on the block. According to Newton's third law of motion,

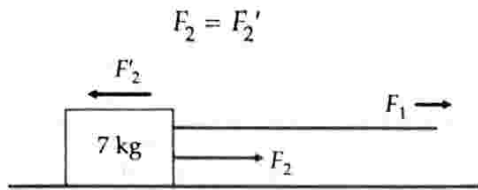

**Fig. 5.42**

As  $F_2'$  is the only force acting on the block which has an acceleration of  $2 \text{ ms}^{-2}$ , so

$$F_2 = F_2' = 7 \times 2 = 14 \text{ N.}$$

**EXAMPLE 39.** A wooden block of mass 2 kg rests on a soft horizontal floor. When an iron cylinder of mass 25 kg is placed on top of the block, the floor yields steadily and the block and the cylinder together go down with an acceleration of  $0.1 \text{ ms}^{-2}$ . What is the action of the block on the floor (a) before and (b) after the floor yields? Take  $g = 10 \text{ ms}^{-2}$ .

[NCERT]

**Solution.** (a) In Fig. 5.43(a), the block is at rest. Its free-body diagram [Fig. 5.43(b)] shows two forces on the block :

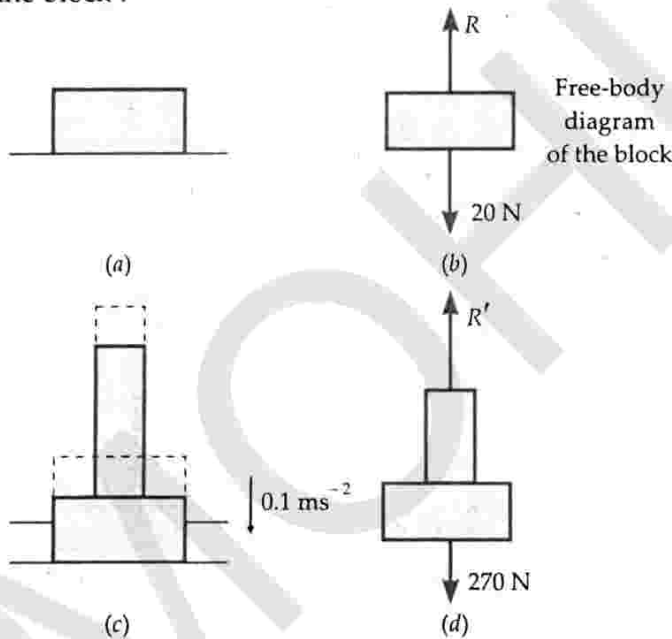

**Fig. 5.43**

- (i) Force of gravitational attraction of the earth  
= Weight of block  
=  $mg = 2 \times 10 = 20 \text{ N}$

(ii) Normal reaction  $R$  of the floor on the block. By the first law, the net force on the block is zero, so  $R = 20 \text{ N}$

By the third law, the action of the block i.e., the force exerted by the block on the floor.

$$= 20 \text{ N, vertically downwards.}$$

(b) In Fig. 5.43(c), the system (block + cylinder) accelerates downwards with  $0.1 \text{ ms}^{-2}$  due to the yielding of the floor. The free-body diagram [Fig. 5.43(d)] shows two forces on system :

- (i) Force of gravity due to the earth  
= Weight of block + system  
=  $(25 + 2) \times 10 = 270 \text{ N}$

(ii) Normal reaction  $R'$  of the floor.

Applying second law to the system, we get

$$270 - R' = (25 + 2) \times 0.1$$

or  $R' = 270 - 2.7 = 267.3 \text{ N}$

By the third law, action of the system on the floor  
= **267.3 N vertically downwards.**

**EXAMPLE 40.** Two blocks of masses  $m_1$  and  $m_2$  in contact lie on a horizontal smooth surface, as shown in Fig. 5.44. The blocks are pushed by a force  $F$ . If the two blocks are always in contact, what is the force at their common interface?

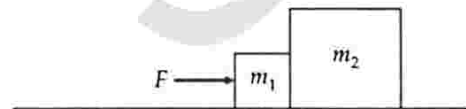

**Fig. 5.44**

**Solution.** From Newton's second law, the common acceleration produced in the system will be

$$a = \frac{F}{m_1 + m_2}$$

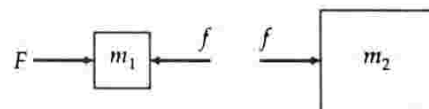
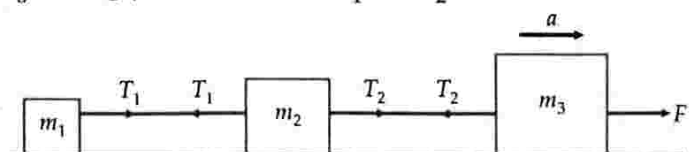

**Fig. 5.45**

If block of mass  $m_1$  exerts force  $f$  on block of mass  $m_2$ , then the force of reaction on block of mass  $m_1$  will be equal and opposite to  $f$ . These forces are shown in the free body diagrams of Fig. 5.45. As the block of mass  $m_2$  has acceleration  $a$ , so

$$f = m_2 a = \frac{m_2 F}{m_1 + m_2}$$

**EXAMPLE 41.** As shown in Fig. 5.46, three blocks connected together lie on a horizontal frictionless table and pulled to the right with a force  $F = 50 \text{ N}$ . If  $m_1 = 5 \text{ kg}$ ,  $m_2 = 10 \text{ kg}$  and  $m_3 = 15 \text{ kg}$ , find the tensions  $T_1$  and  $T_2$ .



**Fig. 5.46**



**Solution.** All the blocks move with common acceleration  $a$  under the force  $F = 50$  N.

$$\therefore F = (m_1 + m_2 + m_3) a$$

or 
$$a = \frac{F}{m_1 + m_2 + m_3} = \frac{50}{5 + 10 + 15} = \frac{5}{3} \text{ ms}^{-2}$$

To determine  $T_1$ . Refer to the free-body diagram for  $m_1$  shown in Fig. 5.47. Clearly, the tension  $T_1$  produces acceleration  $a$  in mass  $m_1$ .

$$\therefore T_1 = m_1 a = 5 \times \frac{5}{3} = \frac{25}{3} = 8.33 \text{ N.}$$

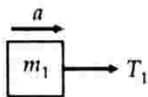

Fig. 5.47

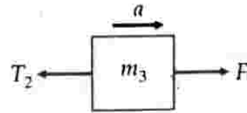

Fig. 5.48

To determine  $T_2$ . Refer to the free-body diagram for  $m_3$  shown in Fig. 5.48. Force  $F$  acts towards right and tension  $T_2$  acts towards left.

$$\therefore F - T_2 = m_3 a \text{ or } 50 - T_2 = 15 \times \frac{5}{3} \text{ or } T_2 = 25 \text{ N.}$$

**EXAMPLE 42.** The masses  $m_1, m_2$  and  $m_3$  of the three bodies shown in Fig. 5.49 are 5, 2 and 3 kg respectively. Calculate the values of the tensions  $T_1, T_2$  and  $T_3$  when (i) the whole system is going upward with an acceleration of  $2 \text{ ms}^{-2}$  and (ii) the whole system is stationary. Given  $g = 9.8 \text{ ms}^{-2}$ .

**Solution.** (i) The three bodies together are moving upward with an acceleration of  $2 \text{ ms}^{-2}$ . The force pulling the system upward is  $T_1$  and the downward force of gravity is  $(m_1 + m_2 + m_3)g$ .

According to Newton's second law,

$$T_1 - (m_1 + m_2 + m_3)g = (m_1 + m_2 + m_3)a$$

or 
$$T_1 = (m_1 + m_2 + m_3)(a + g)$$

$$= (5 + 2 + 3)(2 + 9.8) = 10 \times 11.8$$

$$= 118 \text{ N.}$$

Similarly, for the motion of the system  $m_2 + m_3$ , we can write

$$T_2 = (m_2 + m_3)(a + g)$$

$$= (2 + 3)(2 + 9.8) = 5 \times 11.8$$

$$= 59 \text{ N.}$$

For the motion of body of mass  $m_3$ , we have

$$T_3 = m_3(a + g) = 3(2 + 9.8)$$

$$= 35.4 \text{ N.}$$

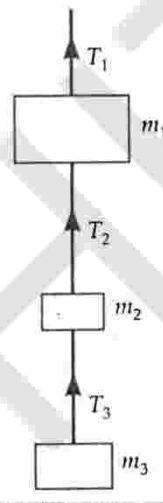

Fig. 5.49

(ii) When the whole system is stationary,  $a = 0$ . From the above equations, we get

$$T_1 = (m_1 + m_2 + m_3)g = 10 \times 9.8 = 98 \text{ N.}$$

$$T_2 = (m_2 + m_3)g = 5 \times 9.8 = 49 \text{ N.}$$

$$T_3 = m_3g = 3 \times 9.8 = 29.4 \text{ N.}$$

**EXAMPLE 43.** A body  $m_1$  of mass 10 kg is placed on a smooth horizontal table. It is connected to a string which passes over a frictionless pulley and carries at the other end, a body  $m_2$  of mass 5 kg. What acceleration will be produced in the bodies when the nail fixed on the table is removed? What will be the tension in the string during the motion of the bodies? What when the bodies stop? Take  $g = 9.8 \text{ N kg}^{-1}$ .

**Solution.** The situation is shown in Fig. 5.50. When the nail fixed on the table is removed, the system of two bodies moves with an acceleration  $a$  in the direction as shown.

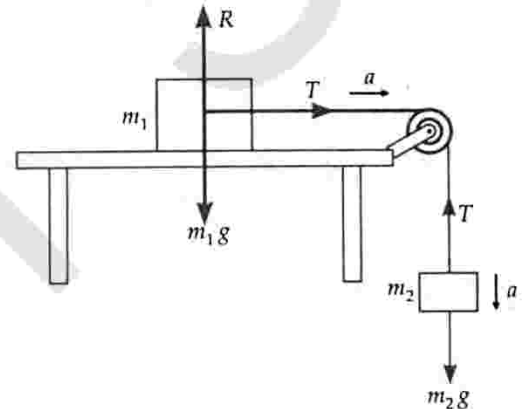

Fig. 5.50

From Newton's second law, we have

$$(m_1 + m_2)a = m_2g$$

$$a = \frac{m_2g}{m_1 + m_2} = \frac{5 \times 9.8}{10 + 5} = 3.27 \text{ ms}^{-2}$$

$$\text{Also, } T = m_1 \times a = 10 \times 3.27 = 32.7 \text{ N}$$

When the bodies stop, acceleration,  $a = 0$ . Suppose the tension in the string becomes  $T'$ . As the net force on each body is zero, so for body  $m_2$ , we can write

$$T' = m_2g = 5 \times 9.8 = 49 \text{ N.}$$

**EXAMPLE 44.** A block of mass 100 kg is set into motion on a frictionless horizontal surface with the help of frictionless pulley and a rope system as shown in Fig. 5.51(a). What horizontal force should be applied to produce in the block an acceleration of  $10 \text{ cms}^{-2}$ ?

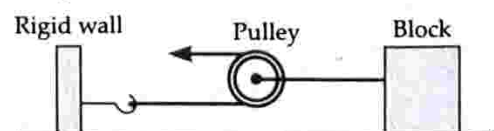
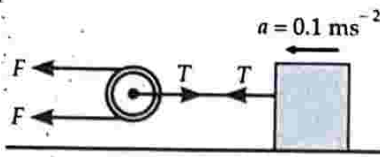

Fig. 5.51 (a)

**Solution.** As shown in Fig. 5.51(b), when force  $F$  is applied at the end of the string, the tension in the lower



**Fig. 5.51 (b)**

part of the string is also  $F$ . If  $T$  is the tension in string connecting the pulley and the block, then from Newton's third law,

$$T = 2F$$

But  $T = ma = 100 \times 0.1 = 10 \text{ N}$

$$\therefore 2F = 10 \text{ N} \quad \text{or} \quad F = 5 \text{ N.}$$

**EXAMPLE 45.** In terms of masses  $m_1, m_2$  and  $g$ , find the acceleration of both the blocks shown in Fig. 5.52. Neglect all friction and masses of the pulley.

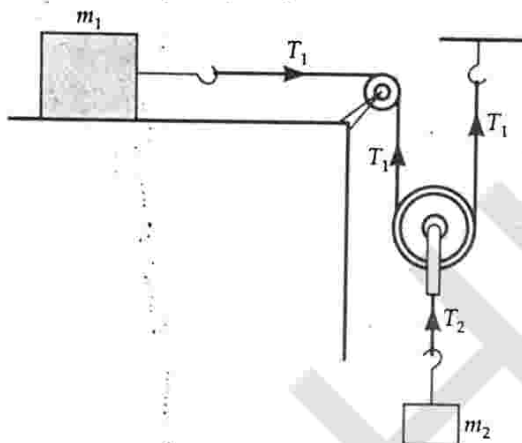

**Fig. 5.52**

**Solution.** As the mass  $m_1$  moves towards right through distance  $x$ , the mass  $m_2$  moves down through distance  $x/2$ . Clearly, if the acceleration of  $m_1$  is  $a$ , then that of  $m_2$  will be  $a/2$ .

Applying Newton's second law to the motions of  $m_1$  and  $m_2$ , we have,

$$T_1 = m_1 a$$

and  $m_2 g - T_2 = m_2 \cdot \frac{a}{2}$

Also  $T_2 = 2T_1 = 2m_1 a$

$$\therefore m_2 g - 2m_1 a = m_2 \cdot \frac{a}{2}$$

or  $2m_2 g - 4m_1 a = m_2 a$  or  $2m_2 g = (4m_1 + m_2) a$

$$\therefore \text{Acceleration of } m_1 = a = \frac{2m_2 g}{4m_1 + m_2}$$

$$\text{Acceleration of } m_2 = \frac{a}{2} = \frac{m_2 g}{4m_1 + m_2}$$

**EXAMPLE 46.** Two identical point masses, each of mass  $M$  are connected to one another by a massless string of length  $L$ . A constant force  $F$  is applied at the mid-point of the string. If  $l$  be the instantaneous distance between the two masses, what will be the acceleration of each mass ?

**Solution.** Fig. 5.53 shows the position of string at any instant after the application of a force  $F$  at the mid point. It also shows the various forces acting on the two masses at any instant. If tension  $T$  in the string is resolved into horizontal and vertical components, then

$$F = 2T \sin \theta \quad \dots(i)$$

and  $Ma = T \cos \theta \quad \dots(ii)$

where  $a$  is the acceleration of each mass.

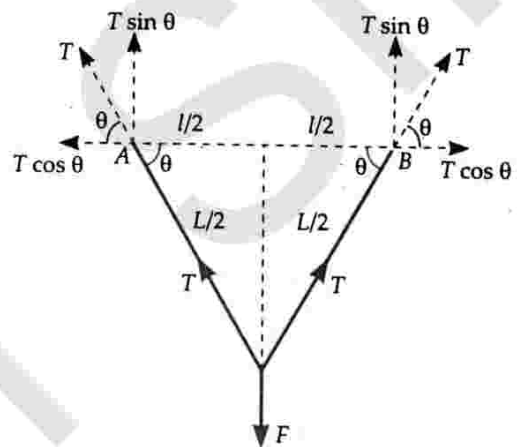

**Fig. 5.53**

Dividing (ii) by (i), we get

$$\frac{\cos \theta}{2 \sin \theta} = \frac{Ma}{F}$$

or  $\cot \theta = \frac{2Ma}{F}$

or  $\frac{l/2}{\sqrt{(L/2)^2 - (l/2)^2}} = \frac{2Ma}{F}$

or  $\frac{2Ma}{F} = \frac{l}{\sqrt{L^2 - l^2}}$

or  $a = \frac{F}{2M} \left( \frac{l}{\sqrt{L^2 - l^2}} \right)$

**EXAMPLE 47.** Two blocks of masses 50 kg and 30 kg connected by a massless string pass over a light frictionless pulley and rest on two smooth planes inclined at angles  $30^\circ$  and  $60^\circ$  respectively with the horizontal. Determine the acceleration of the two blocks and the tension in the string. Take  $g = 10 \text{ ms}^{-2}$ .

**Solution.** Suppose the mass of 50 kg slides down with an acceleration  $a$ . The forces acting on the two

blocks are shown in Fig. 5.54. The components of the two weights perpendicular to the inclined planes are balanced by the normal reactions  $R_1$  and  $R_2$ .

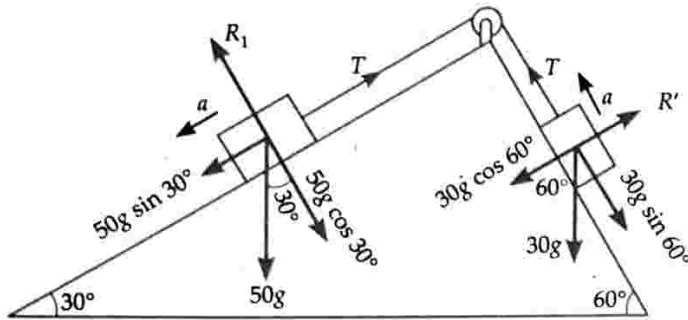

**Fig. 5.54**

The tension  $T$  of each part of the string is same and also the acceleration  $a$  of each block is same.

$$\therefore 50 g \sin 30^\circ - T = 50 a \quad \dots(i)$$

$$\text{and } T - 30 g \sin 60^\circ = 30 a \quad \dots(ii)$$

Adding (i) and (ii), we get

$$(50 \sin 30^\circ - 30 \sin 60^\circ) g = (50 + 30) a$$

$$\text{or } a = \frac{(50 \times 0.5 - 30 \times 0.866) \times 10}{80} = -0.12 \text{ ms}^{-2}$$

The -ve sign indicates that the 50 kg block, instead of sliding down, actually slides up. Hence the 30 kg block slides down and that of 50 kg slides up the inclined plane with  $a = 0.12 \text{ ms}^{-2}$ .

$$\begin{aligned} \text{From (i), } T &= 50 g \sin 30^\circ - 50 a \\ &= 50 (10 \times 0.5 - 0.12) \\ &= 50 \times 4.88 = 244 \text{ N.} \end{aligned}$$

**X PROBLEMS FOR PRACTICE**

1. A force of 9 N pulls a block of 4 kg through a rope of mass 0.5 kg. The block is resting on a smooth surface. What is the force of reaction exerted by the block on the rope? (Ans. 8 N)
2. Two masses  $m_1$  and  $m_2$  are connected by a massless string as shown in Fig. 5.55. Find the value of tension in the string if a force of 200 N is applied on (i)  $m_1$  and (ii)  $m_2$ . [Ans. (i) 125 N (ii) 75 N]

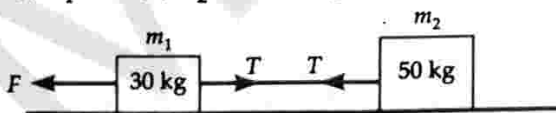

**Fig. 5.55**

3. Two bodies whose masses are  $m_1 = 50 \text{ kg}$  and  $m_2 = 150 \text{ kg}$  are tied by a light string and are placed on a frictionless horizontal surface. When  $m_1$  is pulled by a force  $F$ , and acceleration of  $5 \text{ ms}^{-2}$  is produced in both the bodies. Calculate the value of  $F$ . What is the tension in the string? (Ans. 1000 N, 750 N)

4. As shown in Fig. 5.56, three masses  $m$ ,  $3m$  and  $5m$  connected together lie on a frictionless horizontal surface and pulled to the left by a force  $F$ . The

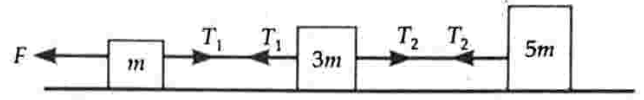
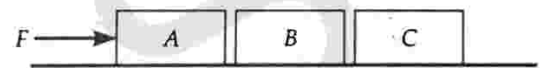

**Fig. 5.56**

tension  $T_1$  in the first string is 24 N. Find (i) acceleration of the system, (ii) tension in the second string, and (iii) force  $F$ .

$$[\text{Ans. (i) } a = 3/m \text{ (ii) } T_2 = 15 \text{ N (iii) } F = 27 \text{ N}]$$

5. Three identical blocks, each having a mass  $m$  are pushed by a force  $F$  on a frictionless table as shown in Fig. 5.57. What is the acceleration of the blocks?



**Fig. 5.57**

What is the net force on the block A? What force does A apply on B? What force does B apply on C? Show action-reaction pairs on the contact surfaces of the blocks. (Ans.  $F/3$ ,  $F/3$ ,  $2F/3$ ,  $F/3$ )

6. Four blocks of the same mass  $m$  connected by cords are pulled by a force  $F$  on a smooth horizontal

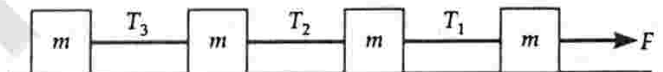

**Fig. 5.58**

surface, as shown in Fig. 5.58. Determine the tensions  $T_1$ ,  $T_2$  and  $T_3$  in the cords.

$$[\text{Ans. } T_1 = \frac{3}{4} F, T_2 = \frac{1}{2} F, T_3 = \frac{1}{4} F]$$

7. In Fig. 5.59, find the acceleration  $a$  of the system and the tensions  $T_1$  and  $T_2$  in the strings. Assume that the table and the pulleys are frictionless and the strings are massless. Take  $g = 9.8 \text{ ms}^{-2}$ .

$$[\text{Ans. } 1.4 \text{ ms}^{-2}, 22.4 \text{ N}, 33.6 \text{ N}]$$

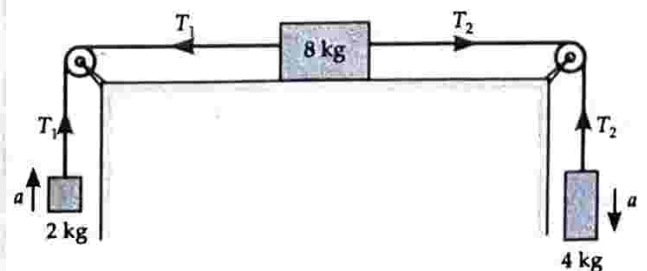

**Fig. 5.59**

8. In the Atwood's machine [Fig. 5.60], the system starts from rest. What is the speed and distance moved by each mass at  $t = 3\text{ s}$ ?

(Ans.  $2.67\text{ ms}^{-1}$ ,  $4\text{ m}$ )

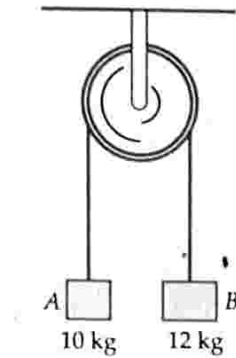

Fig. 5.60

9. Three bodies A, B and C, each of mass  $m$  are hanging on a string over a fixed pulley, as shown in Fig. 5.61. What are the tensions in the strings connecting bodies A to B and B to C? (Ans.  $\frac{4}{3}mg$ ,  $\frac{2}{3}mg$ )

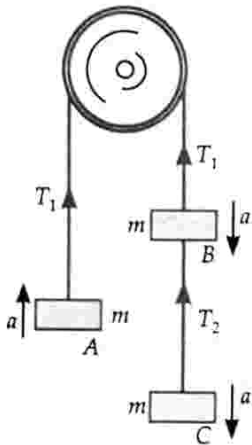

Fig. 5.61

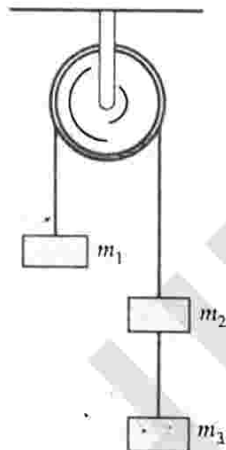

Fig. 5.62

10. In the arrangement shown in Fig. 5.62, show that the tension in the string between masses  $m_2$  and  $m_3$  is  $T = \frac{2m_1 m_3 g}{m_1 + m_2 + m_3}$ .

**HINTS**

4. (i) Tension  $T_1$  of  $24\text{ N}$  pulls the masses  $(3m + 5m)$  with acceleration  $a$ .  
 $\therefore 24 = (3m + 5m)a$  or  $a = 3/m$ .  
 (ii) Tension  $T_2$  pulls mass  $5m$  with acceleration  $3/m$ .  
 $\therefore T_2 = 5m \times \frac{3}{m} = 15\text{ N}$ .  
 (iii)  $F = (m + 3m + 5m)a = 9m \times \frac{3}{m} = 27\text{ N}$ .

5. Let  $a$  be the common acceleration. Then

$$F = 3m \times a \text{ or } a = F/3m$$

Net force on block A will be

$$F_1 = m \times a = m \times \frac{F}{3m} = \frac{F}{3}$$

Force applied by A on B,

$$F_2 = (m_1 + m_2)a = 2m \times \frac{F}{3m} = \frac{2F}{3}$$

Force applied by B on C,

$$F_3 = m \times a = m \times \frac{F}{3m} = \frac{F}{3}$$

The action-reaction forces are shown in Fig. 5.63.

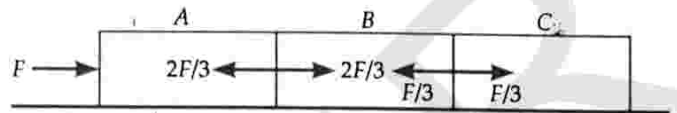

Fig. 5.63

6. Let  $a$  be the common acceleration of the system. Then

$$F = (m + m + m + m)a = 4ma \text{ or } a = \frac{F}{4m}$$

Applying Newton's 2nd law separately for each block in Fig. 5.64, we get

$$F - T_1 = ma, T_1 - T_2 = ma, T_2 - T_3 = ma, T_3 = ma$$

On solving the above equations, we get

$$T_1 = \frac{3}{4}F, T_2 = \frac{1}{2}F, T_3 = \frac{1}{4}F$$

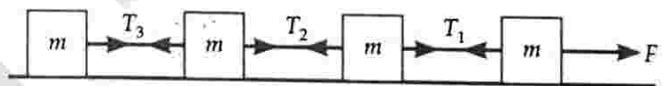

Fig. 5.64

7. Here  $4g - T_2 = 4a$ ,  $T_1 - 2g = 2a$  and  $T_2 - T_1 = 8a$ .  
 On solving,  $a = 1.4\text{ ms}^{-2}$ ,  $T_1 = 22.4\text{ N}$ ,  $T_2 = 33.6\text{ N}$ .

8. Acceleration,

$$a = \frac{M - m}{M + m}g = \frac{12 - 10}{12 + 10} \times 9.8 = 0.89\text{ ms}^{-2}$$

$$v = u + at = 0 + 0.89 \times 3 = 2.67\text{ ms}^{-1}$$

$$s = ut + \frac{1}{2}at^2 = 0 + \frac{1}{2} \times 0.89 \times 9 = 4\text{ m}$$

9. Here  $T_1 - mg = ma$ ,  $2mg - T_1 = 2ma$  and

$$mg - T_2 = ma$$

On solving,  $a = \frac{2}{3}$ ,  $T_1 = \frac{4}{3}mg$  and  $T_2 = \frac{2}{3}mg$ .

10.  $m_1a = T_1 - m_1g$  ... (i)

$$(m_2 + m_3)a = (m_2 + m_3)g - T_1 \text{ ... (ii)}$$

$$m_3a = m_3g - T \text{ ... (iii)}$$

Adding (i) and (ii), get the value of  $a$  and put in (iii).

5.22 ▽ FRICTION

47. What is friction ? Explain it with an example.

**Friction.** Whenever a body moves or tends to move over the surface of another body, a force comes into play which acts parallel to the surface of contact and opposes the relative motion. This opposing force is called friction.

**Example.** Consider a wooden block placed on a horizontal surface. Give it a gentle push. The block slides through a small distance and then comes to rest. According to Newton's second law, a retarding force must be acting on the block. This opposing force is called friction. As shown in Fig. 5.65, the force of friction always acts tangential to the surfaces in contact and in a direction opposite to the direction of (relative) motion of the body.

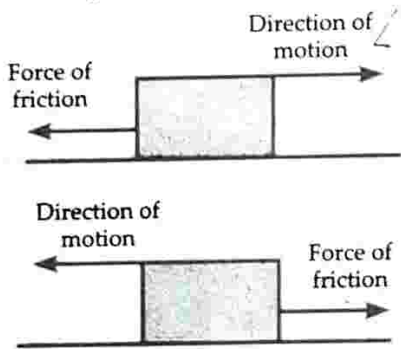

Fig. 5.65 Force of friction always opposes relative motion.

48. How is friction a component of the contact force ?

**Friction as the component of contact force.** When two bodies are placed in contact, attractive forces act between their particles at the surface of contact. As a result, each body exerts a contact force on the other. These mutual contact forces are equal and opposite, obeying Newton's third law. The component of the contact force  $F$  normal to the contact surface is called *normal force* or *normal reaction*  $N$ . The component parallel to the contact surface is called *friction*.

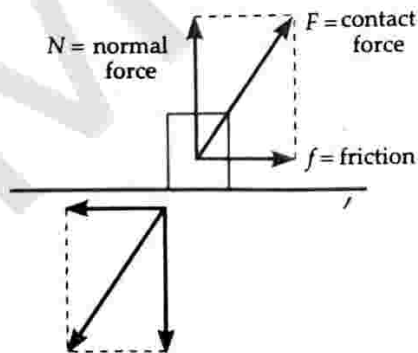

Fig. 5.66 Friction as a component of contact force.

49. Explain the origin of the force of friction.

**Origin of friction.** The force of friction is due to the atomic or molecular forces of attraction between the two surfaces at the points of actual contacts. Fig. 5.67 shows two surfaces in contact, as seen through a powerful microscope. Due to the surface irregularities,

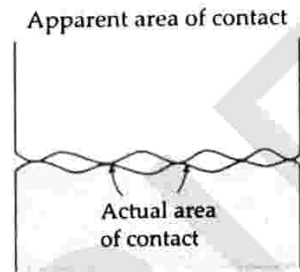

Fig. 5.67 Cause of sliding friction.

the actual area of contact is much smaller than the apparent area of contact. The pressure at the points of contacts is very large. Molecular bonds are formed at these points. When one body is pulled over the other, the bonds break, the material is deformed and new bonds are formed. The local deformation sends vibration waves into the bodies. These vibrations finally damp out and energy appears as heat. Hence a force is needed to start or maintain the motion.

5.23 ▽ STATIC, LIMITING AND KINETIC FRICTIONS

50. With the help of a suitable example, explain the terms static friction, limiting friction and kinetic friction. Show that static friction is a self-adjusting force.

**Static, limiting and kinetic frictions :** static friction is a self-adjusting force. Consider a wooden block placed over a horizontal table. Apply a small force  $F$  on it [Fig. 5.68(a)]. The block does not move. The force of friction  $f$  comes into action which balances the applied force  $F$ .

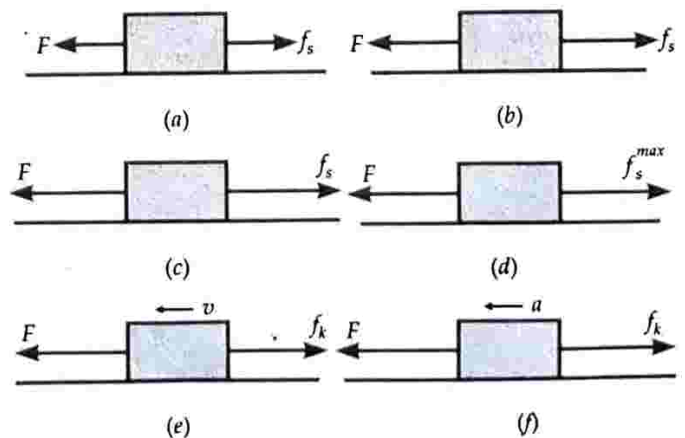

Fig. 5.68 Types of friction.

The force of friction which comes into play between two bodies before one body actually starts moving over the other is called **static friction** ( $f_s$ ).

Static friction opposes the impending motion *i.e.*, the motion that would take place (but does not take place) under the applied force, if friction were absent.

As the applied force on the block is increased, the static friction  $f_s$  also increases [Fig. 5.68(b) and (c)] to balance the applied force and the block does not move. Once the applied force is increased beyond a certain limit, the block just begins to move. At this stage static friction is maximum [Fig. 5.68(d)].

The maximum force of static friction ( $f_s^{max}$ ) which comes into play when a body just starts moving over the surface of another body is called **limiting friction**. Clearly  $f_s \leq f_s^{max}$ .

Once the motion has begun, the force of friction decreases. A smaller force is now necessary to maintain uniform motion.

The force of friction which comes into play when a body is in a state of steady motion over the surface of another body is called **kinetic or dynamic friction** ( $f_k$ ) [Fig. 5.68(e)]. When  $F = f_k$ , the body moves with a constant velocity  $v$ . The kinetic friction opposes the actual relative motion.

When the applied force becomes greater than the kinetic friction, the block accelerates with acceleration equal to  $(F - f_k)/m$  [Fig. 5.68(f)].

Fig. 5.69 shows the variation of the force of friction  $f$  with the applied force  $F$ . Obviously, as the applied force  $F$  increases, the static friction  $f_s$  increases accordingly to balance it. This shows that *static friction is a self adjusting force*. The kinetic friction is always less than the limiting friction  $f_s^{max}$  *i.e.*,  $f_k < f_s^{max}$ .

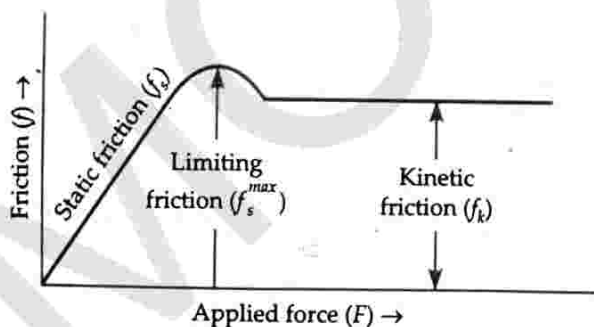

**Fig. 5.69** Variation of the force of friction with the applied force.

## 5.24 ▼ LAWS OF FRICTION AND COEFFICIENTS OF FRICTION

**51.** State the laws of limiting friction. Define coefficient of limiting friction.

**Laws of limiting friction.** From experimental studies, the limiting friction is found to obey the following laws :

- The limiting friction depends on the nature of the surfaces in contact and their state of polish.
- The limiting friction acts tangential to the two surfaces in contact and in a direction opposite to the direction of motion of the body.
- The value of limiting friction is independent of the area of the surface in contact so long as the normal reaction remains the same.
- The limiting friction ( $f_s^{max}$ ) is directly proportional to the normal reaction  $R$  between the two surfaces.

$$\text{i.e., } f_s^{max} \propto R \quad \text{or} \quad f_s^{max} = \mu_s R$$

$$\text{or} \quad \mu_s = \frac{f_s^{max}}{R} = \frac{\text{Limiting friction}}{\text{Normal reaction}}$$

The proportionality constant  $\mu_s$  is called **coefficient of static friction**. It is defined as the ratio of limiting friction to the normal reaction.

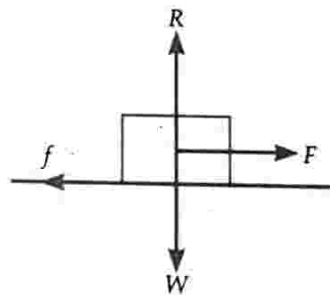

**Fig. 5.70**

**52.** State the laws of kinetic friction. Define coefficient of kinetic friction. Is it less than or greater than the coefficient of static friction ?

**Laws of kinetic friction.** These may be stated as follows :

- The kinetic friction opposes the relative motion and has a constant value, depending on the nature of the two surfaces in contact.
- The value of kinetic friction  $f_k$  is independent of the area of contact so long as the normal reaction remains the same.
- The kinetic friction does not depend on velocity, provided the velocity is neither too large nor too small.
- The value of kinetic friction  $f_k$  is directly proportional to the normal reaction  $R$  between the two surfaces.

$$\text{i.e., } f_k \propto R \quad \text{or} \quad f_k = \mu_k R$$

$$\text{or} \quad \mu_k = \frac{f_k}{R} = \frac{\text{Kinetic friction}}{\text{Normal reaction}}$$

The proportionality constant  $\mu_k$  is called **coefficient of kinetic friction**. It is defined as the ratio of kinetic friction to the normal reaction

$$\text{As } f_k < f_s^{max} \text{ or } \mu_k R < \mu_s R \quad \therefore \mu_k < \mu_s.$$

Thus the coefficient of kinetic friction is less than the coefficient of static friction.

### 5.25 ▽ ANGLE OF FRICTION

53. Define angle of friction. Deduce its relation with coefficient of friction.

**Angle of friction.** The angle of friction may be defined as the angle which the resultant of the limiting friction and the normal reaction makes with the normal reaction.

**Relation between angle of friction and coefficient of friction.** In Fig. 5.71,  $W$  is the weight of the body,  $R$  is the normal reaction,  $f_s^{max}$  is the limiting friction,  $P$  is the applied force and  $\vec{OC}$  is the resultant of  $f_s^{max}$  and  $R$ . The angle  $\theta$  between the normal reaction  $R$  and the resultant  $\vec{OC}$  is, by definition, the angle of friction.

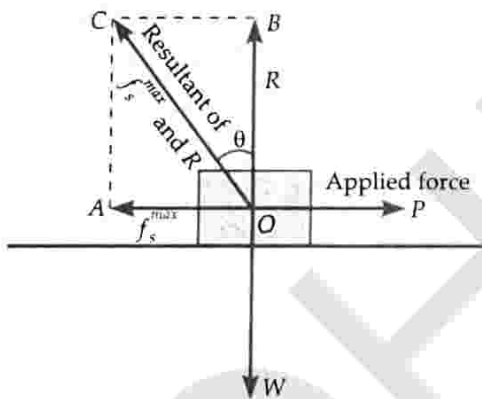

Fig. 5.71 Angle of friction.

$$\therefore \tan \theta = \frac{BC}{OB} = \frac{OA}{OB} = \frac{f_s^{max}}{R}$$

But  $\frac{f_s^{max}}{R} = \mu_s = \text{Coefficient of static friction}$

$$\therefore \tan \theta = \mu_s$$

Thus the coefficient of static friction is equal to the tangent of the angle of friction.

### 5.26 ▽ ANGLE OF REPOSE

54. Define angle of repose. Deduce its relation with coefficient of static friction ?

**Angle of repose.** It is the minimum angle that an inclined plane makes with the horizontal when a body placed on it just begins to slide down.

**Relation between angle of repose and coefficient of friction.** As shown in Fig. 5.72, consider a body of

mass  $m$  placed on an inclined plane. The angle of inclination  $\phi$  of the inclined plane is so adjusted that a body placed on it just begins to slide down. Thus  $\phi$  is the angle of repose.

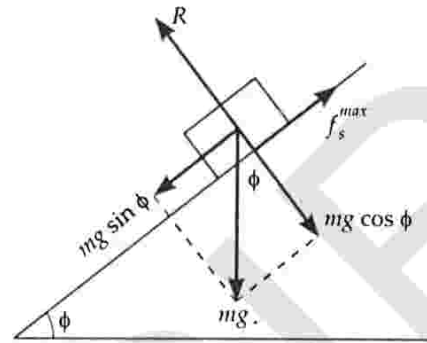

Fig. 5.72 Angle of repose.

Various forces acting on the body are :

- (i) Weight  $mg$  of the body acting vertically downwards.
- (ii) The limiting friction  $f_s^{max}$  in upward direction along the inclined plane. It balances the component  $mg \sin \phi$  of the weight  $mg$  along the inclined plane. Thus

$$f_s^{max} = mg \sin \phi \quad \dots(1)$$

- (iii) The normal reaction  $R$  perpendicular to the inclined plane. It balances the component  $mg \cos \phi$  of the weight  $mg$  perpendicular to the inclined plane. Thus

$$R = mg \cos \phi \quad \dots(2)$$

Dividing equation (1) by (2), we get

$$\frac{f_s^{max}}{R} = \frac{mg \sin \phi}{mg \cos \phi}$$

or  $\mu_s = \tan \phi$

Thus the coefficient of static friction is equal to the tangent of the angle of repose.

As  $\mu_s = \tan \theta = \tan \phi \quad \therefore \theta = \phi$

Thus the angle of repose is equal to the angle of friction.

### 5.27 ▽ SLIDING AND ROLLING FRICTIONS

55. What are the two types of kinetic friction ? Which one of them is smaller than the other ?

**Types of kinetic friction.** Kinetic friction is of two types :

- (i) **Sliding friction.** The force of friction that comes into play when a body slides over the surface of another body is called sliding friction. When a wooden block is pulled or pushed over a horizontal surface, sliding friction comes into play.

(ii) **Rolling friction.** The force of friction that comes into play when a body rolls over the surface of another body is called rolling friction. When a wheel rolls over a road, rolling friction comes into play.

For the same magnitude of normal reaction, rolling friction is always much smaller than the sliding friction.

**56. Why is friction greatly reduced when a body rolls over a surface? What is the cause of rolling friction?**

**Rolling friction is smaller than sliding friction.** When a wheel rolls without slipping over a horizontal plane, the surfaces at contact do not rub each other. The relative velocity of the point of contact of the wheel with respect to the plane is zero, if there is no slipping. There is no sliding or static friction in such an ideal situation. We need to overcome rolling friction only which is much smaller than sliding friction. For this reason, wheel has been considered as one of the greatest inventions.

**Cause of rolling friction.** Consider a wheel rolling along a road. As the wheel rolls, it exerts a large pressure (weight/area) due to its small area. This causes a slight depression of the road below and a small elevation or

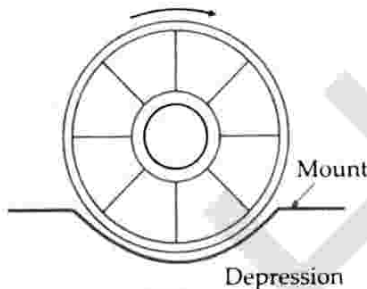

**Fig. 5.73** Cause of rolling friction.

mount in front of it. In addition to this, the rolling wheel has to continuously detach itself from the surface on which it rolls. This is opposed by the adhesive force between the two surfaces in contact. On account of both of these factors, a force originates which retards the rolling motion. This retarding force is known as rolling friction.

**57. On what factors does the rolling friction depend? Write an expression for the coefficient of rolling friction.**

**Laws of rolling friction.** Experiments show that

(i) Rolling friction is directly proportional to the normal reaction i.e.,

$$f_r \propto R$$

(ii) Rolling friction is inversely proportional to the radius of the rolling cylinder or wheel i.e.,

$$f_r \propto \frac{1}{r}$$

Combining the two laws, we get

$$f_r \propto \frac{R}{r} \quad \text{or} \quad f_r = \mu_r \frac{R}{r}$$

Here  $\mu_r$  is the coefficient of rolling friction. Unlike  $\mu_s$  or  $\mu_k$  (which is a pure ratio and has no dimensions),  $\mu_r$  has the dimensions of length and its SI unit is metre. The above equation is applicable only when there is rolling without slipping.

### Examples based on Coefficient of Friction and Angle of Friction

#### FORMULAE USED

1. Coefficient of limiting friction =  $\frac{\text{Limiting friction}}{\text{Normal reaction}}$   
or  $\mu_s = \frac{f_s^{\max}}{R}$  or  $f_s^{\max} = \mu_s R$
2. Coefficient of kinetic friction =  $\frac{\text{Kinetic friction}}{\text{Normal reaction}}$   
or  $\mu_k = \frac{f_k}{R}$  or  $f_k = \mu_k R$
3. For a body placed on horizontal surface,  $R = mg$   
 $\therefore f_s^{\max} = \mu_s \cdot mg$  and  $f_k = \mu_k \cdot mg$
4. Static friction,  $f_s \leq f_s^{\max}$  or  $f_s \leq \mu_s R$
5. Kinetic friction,  $f_k < f_s^{\max}$ .
6. If  $\theta$  is the angle of friction, then  $\mu_s = \tan \theta$
7. If  $\phi$  is the angle of repose, then  $\mu_s = \tan \phi$
8. Angle of repose = Angle of friction i.e.,  $\theta = \phi$
9. For a body moving on a rough horizontal surface with retardation  $a$ ,  $\mu = \frac{f}{R} = \frac{ma}{mg} = \frac{a}{g}$
10.  $f_r = \mu_r \cdot \frac{R}{r}$  and  $\mu_r < \mu_k < \mu_s$

where  $\mu_r$  is the coefficient of rolling friction,  $f_r$  is the rolling friction and  $r$  is the radius of the rolling body.

#### UNITS USED

Force of friction  $f$  and normal reaction  $R$  are in newton (N), coefficient of friction  $\mu$  has no units.

**EXAMPLE 48.** A block of mass 2 kg is placed on the floor. The coefficient of static friction is 0.4. A force of friction of 2.5 N is applied on the block as shown in Fig. 5.74. Calculate the force of friction between the block and the floor.

[REC 95]



**Fig. 5.74**



**Solution.** Here  $m = 2 \text{ kg}$ ,  $\mu_s = 0.4$ ,  $g = 9.8 \text{ ms}^{-2}$

The value of limiting friction,

$$f_s^{\max} = \mu_s R = \mu_s \cdot mg = 0.4 \times 2 \times 9.8 = 7.84 \text{ N}$$

As the applied force of 2.5 N is less than the limiting friction (7.84 N), so the block does not move. In this situation,

Force of friction = Applied force = 2.5 N.

**EXAMPLE 49.** A block of weight 20 N is placed on a horizontal table and a tension  $T$ , which can be increased to 8 N before the block begins to slide, is applied at the block as shown in Fig. 5.75. A force of 4 N keeps the block moving at constant speed once it has been set in motion. Find the coefficient of static and kinetic friction.

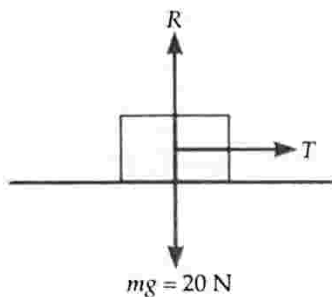

**Fig. 5.75**

**Solution.** For static friction : We have the following relations for vertical and horizontal component of forces :

$$R - mg = 0 \text{ or } R = mg = 20 \text{ N}$$

$$\text{and } T - f_s^{\max} = 0 \text{ or } f_s^{\max} = T = 8 \text{ N}$$

$\therefore$  Coefficient static friction,

$$\mu_s = \frac{f_s^{\max}}{R} = \frac{8}{20} = 0.40.$$

For kinetic friction : We can write the following relations :

$$R - mg = 0 \text{ or } R = mg = 20 \text{ N}$$

$$\text{and } T - f_k = 0 \text{ or } f_k = T = 4 \text{ N}$$

$\therefore$  Coefficient of kinetic friction,

$$\mu_k = \frac{f_k}{R} = \frac{4}{20} = 0.20.$$

**EXAMPLE 50.** A force of 49 N is just sufficient to pull a block of wood weighing 10 kg on a rough horizontal surface. Calculate the coefficient of friction and angle of friction.

**Solution.** Here  $P =$  applied force = 49 N,

$$m = 10 \text{ kg}, g = 9.8 \text{ ms}^{-2}$$

Coefficient of friction,

$$\mu = \frac{f}{R} = \frac{P}{mg} = \frac{49}{10 \times 9.8} = 0.5$$

$$\text{As } \tan \theta = \mu = 0.5$$

$$\therefore \theta = \tan^{-1}(0.5) = 26^\circ 34'.$$

**EXAMPLE 51.** A cubical block rests on an inclined plane of  $\mu = 1/\sqrt{3}$ , determine the angle of inclination when the block just slides down the inclined plane.

**Solution.** When the block just slides down the inclined plane, the angle of inclination is equal to the angle of repose ( $\alpha$ ).

$$\therefore \tan \alpha = \mu = \frac{1}{\sqrt{3}} \text{ or } \alpha = 30^\circ.$$

**EXAMPLE 52.** A mass of 4 kg rests on a horizontal plane. The plane is gradually inclined until at an angle  $\theta = 15^\circ$  with the horizontal, the mass just begins to slide. What is the coefficient of static friction between the block and the surface? [NCERT]

**Solution.** Here  $\theta = 15^\circ$  is the angle of repose.

$$\therefore \text{Coefficient of friction, } \mu = \tan \theta = \tan 15^\circ = 0.27.$$

**EXAMPLE 53.** A body rolled on ice with a velocity of  $8 \text{ ms}^{-1}$  comes to rest after travelling 4 m. Compute the coefficient of friction. Given  $g = 9.8 \text{ ms}^{-2}$ .

**Solution.** Here  $u = 8 \text{ ms}^{-1}$ ,  $v = 0$ ,  $s = 4 \text{ m}$ ,  $a = ?$

$$\text{As } v^2 - u^2 = 2as$$

$$\therefore 0^2 - 8^2 = 2a \times 4 \text{ or } a = -\frac{64}{8} = -8 \text{ ms}^{-2}$$

Negative sign indicates retardation.

$$\text{Now } \mu = \frac{f}{R} = \frac{ma}{mg} = \frac{a}{g} = \frac{8}{9.8} = 0.8164.$$

**EXAMPLE 54.** The coefficient of friction between the ground and the wheels of a car moving on a horizontal road is 0.5. If the car starts from rest, what is the minimum distance in which it can acquire a speed of  $72 \text{ kmh}^{-1}$ ? Take  $g = 10 \text{ ms}^{-2}$ .

**Solution.** Here  $\mu = 0.5$ ,  $u = 0$ ,

$$v = 72 \text{ kmh}^{-1} = 72 \times \frac{5}{18} = 20 \text{ ms}^{-1}$$

$$\text{As } \mu = \frac{f}{R} = \frac{ma}{mg} = \frac{a}{g}$$

$$\therefore a = \mu g = 0.5 \times 10 = 5 \text{ ms}^{-2}$$

$$\text{As } v^2 - u^2 = 2as$$

$$\therefore (20)^2 - 0^2 = 2 \times 5 \times s \text{ or } s = \frac{400}{10} = 40 \text{ m}.$$

**EXAMPLE 55.** Determine the maximum acceleration of the train in which a box lying on its floor will remain stationary, given that the coefficient of static friction between the box and the train's floor is 0.15. Take  $g = 10 \text{ ms}^{-2}$ . [NCERT]

**Solution.** As the acceleration of the box is due to static friction, so

$$ma = f \leq \mu_s R = \mu_s mg$$

$$\therefore a \leq \mu_s g$$

$$\text{or } a_{\max} = \mu_s g = 0.15 \times 10 = 1.5 \text{ ms}^{-2}.$$

**EXAMPLE 56.** A bullet of mass 0.01 kg is fired horizontally into a 4 kg wooden block at rest on a horizontal surface. The coefficient of the kinetic friction between the block and the surface is 0.25. The bullet gets embedded in the block and the combination moves 20 m before coming to rest. With what speed did the bullet strike the block ?

**Solution.** Mass of block,  $M = 4$  kg

Mass of bullet,  $m = 0.01$  kg

After the bullet gets embedded in the block, the force of kinetic friction is

$$f_k = \mu_k R = \mu_k (M + m) g$$

If the kinetic friction produces retardation  $a$  in the system, then

$$f_k = (M + m) a$$

$$\therefore (M + m) a = \mu_k (M + m) g$$

or  $a = \mu_k \times g = 0.25 \times 9.8 = 2.45 \text{ ms}^{-2}$

After the bullet enters the block, suppose the system attains velocity  $V$ . Now the system comes to rest after covering a distance,  $s = 20$  m, as shown in Fig. 5.76.

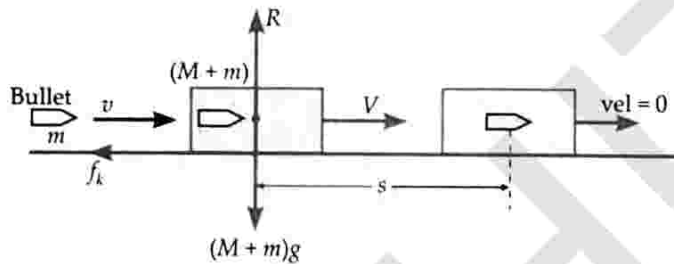

**Fig. 5.76**

As  $v^2 - u^2 = 2 as$

$$\therefore 0 - V^2 = 2 \times (-2.45) \times 20$$

or  $V = \sqrt{98} = 9.8995 \text{ ms}^{-1}$

If  $v$  is the velocity with which the bullet struck the block, then applying the law of conservation of momentum, we get

$$mv = (M + m) V$$

or  $v = \frac{M + m}{m} \cdot V = \frac{4 + 0.01}{0.01} \times 9.8995$   
 $= 401 \times 9.8995 = 3969.7 \text{ ms}^{-1}$

**EXAMPLE 57.** What is the acceleration of the block and the trolley system shown in Fig. 5.77, if the coefficient of kinetic friction between the trolley and the surface is 0.04 ? What is the tension in the string ? Take  $g = 10 \text{ ms}^{-2}$ . Neglect the mass of the string. [NCERT ; Chandigarh 07]

**Solution.** As the block and the trolley are connected together by a string of fixed length, both will have same acceleration  $a$ .

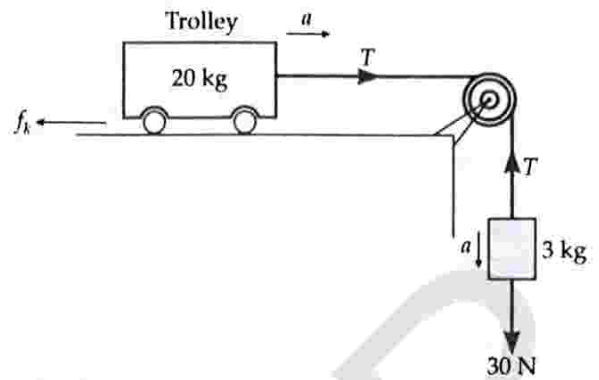

**Fig. 5.77**

Applying Newton's second law to the motion of the block,

$$30 - T = 3a \quad \dots(i)$$

Applying second law to the motion of the trolley,

$$T - f_k = 20 a$$

But  $f_k = \mu_k R = \mu_k mg = 0.04 \times 20 \times 10 = 8 \text{ N}$

$$\therefore T - 8 = 20 a \quad \dots(ii)$$

Adding (i) and (ii), we get

$$22 = 23 a \text{ or } a = \frac{22}{23} = 0.96 \text{ ms}^{-2}$$

From (i),  $30 - T = 3 \times 0.96$

or  $T = 30 - 2.88 = 27.12 \text{ N}$ .

**EXAMPLE 58.** A block A of mass 4 kg is placed on another block B of mass 5 kg, and the block B rests on a smooth horizontal table. For sliding the block A on B, a horizontal force of 12 N is required to be applied on it. How much maximum horizontal force can be applied on B so that both A and B move together ? Also find out the acceleration produced by this force.

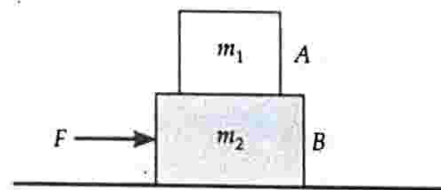

**Fig. 5.78**

**Solution.** Here  $m_1 = 4$  kg,  $m_2 = 5$  kg

Force applied on block A = 12 N

This force must atleast be equal to the kinetic friction applied on A by B.

$$\therefore 12 = f_k = \mu_k R = \mu_k m_1 g$$

or  $12 = \mu_k \times 4 g$

or  $\mu_k = \frac{12}{4 g} = \frac{3}{g}$

The block  $B$  is on a smooth surface. Hence to move  $A$  and  $B$  together, the (maximum) force  $F$  that can be applied on  $B$  is equal to the frictional forces applied on  $A$  by  $B$  and applied on  $B$  by  $A$ .

$$\begin{aligned} F &= \mu_k m_1 g + \mu_k m_2 g = \mu_k (m_1 + m_2) g \\ &= \frac{3}{8} (4 + 5) g = 27 \text{ N} \end{aligned}$$

As this force moves both the blocks together on a smooth table, so the acceleration produced is

$$a = \frac{F}{m_1 + m_2} = \frac{27}{4 + 5} = 3 \text{ ms}^{-2}.$$

**EXAMPLE 59.** An engine of 100 H.P. draws a train of mass 200 metric ton with a velocity of  $36 \text{ kmh}^{-1}$ . Find the coefficient of friction.

**Solution.** Power of engine,

$$P = 100 \text{ H.P.} = 100 \times 746 = 74600 \text{ W}$$

$$\text{Velocity, } v = 36 \text{ kmh}^{-1} = 10 \text{ ms}^{-1}$$

If the frictional force overcome by the engine is  $F$ , then

$$P = F \times v \quad \text{or} \quad F = \frac{P}{v} = \frac{74600}{10} = 7460 \text{ N}$$

Normal reaction,

$$R = mg = 200 \times 1000 \times 9.8 \text{ N}$$

Coefficient of friction,

$$\mu = \frac{F}{R} = \frac{7460}{200 \times 1000 \times 9.8} = 0.0038.$$

### ✕ PROBLEMS FOR PRACTICE

- A block of mass 1 kg lies on a horizontal surface in a truck. The coefficient of static friction between the block and the surface is 0.6. If the acceleration of the truck is  $5 \text{ ms}^{-2}$ , calculate the frictional force acting on the block. (IIT 84) (Ans. 5 N)
- A body weighing 20 kg just slides down a rough inclined plane that rises 5 m in every 13 m. What is the coefficient of friction? (Ans. 0.4167)
- A scooter weighs 120 kg f. Brakes are applied so that wheels stop rolling and start skidding. Find the force of friction if the coefficient of friction is 0.4. (Ans. 48 kg f)
- An automobile is moving on a horizontal road with a speed  $v$ . If the coefficient of friction between the tyres and road is  $\mu$ , show that the shortest distance in which the automobile can be stopped is  $v^2 / 2\mu g$ .
- Find the distance travelled by a body before coming to rest, if it is moving with a speed of  $10 \text{ ms}^{-1}$  and the coefficient of friction between the ground the body is 0.4. (Ans. 12.75 m)
- A motor car running at the rate of  $7 \text{ ms}^{-1}$  can be stopped by applying brakes in 10 m. Show that total resistance to the motion, when brakes are on, is one fourth of the weight of the car.
- Find the power of an engine which can maintain a speed of  $50 \text{ ms}^{-1}$  for a train of mass  $3 \times 10^5 \text{ kg}$  on a rough line. The coefficient of friction is 0.05. Take  $g = 10 \text{ ms}^{-2}$ . (Ans. 7500 kW)
- A train weighing 1000 quintals is running on a level road with a uniform speed of  $72 \text{ km h}^{-1}$ . If the frictional resistance amounts to 50 g wt per quintal, find power in watt. Take  $g = 9.8 \text{ ms}^{-2}$ . (Ans. 9800 W)
- An automobile of mass  $m$  starts from rest and accelerates at a maximum rate possible without slipping on a road with  $\mu_s = 0.5$ . If only the rear wheels are driven and half the weight of the automobile is supported on these wheels, how much time is required to reach a speed of  $100 \text{ kmh}^{-1}$ . (Ans. 11.3 s)
- A suitcase is gently dropped on a conveyor belt moving at  $3 \text{ ms}^{-1}$ . If the coefficient of friction between the belt and the suitcase is 0.5, how far will the suitcase move on the belt before coming to rest? (Ans. 0.92 m)
- A truck moving at  $72 \text{ kmh}^{-1}$  carries a steel girder which rests on its wooden floor. What is the minimum time in which the truck can come to stop without the girder moving forward? Coefficient of static friction between steel and wood is 0.5. (Ans. 4.08 s)
- A bullet of mass 10 g is fired horizontally into a 5 kg wooden block, at rest on a horizontal surface. The coefficient of kinetic friction between the block and the surface is 0.1. Calculate speed of the bullet striking the block, if the combination moves 20 m before coming to rest. (Ans. 3136.26  $\text{ms}^{-1}$ )
- In Fig. 5.79, the masses of  $A$  and  $B$  are 10 kg and 5 kg respectively. Calculate the minimum mass of  $C$  which may stop  $A$  from slipping. Coefficient of static friction between  $A$  and the table is 0.2. (Ans. 15 kg)

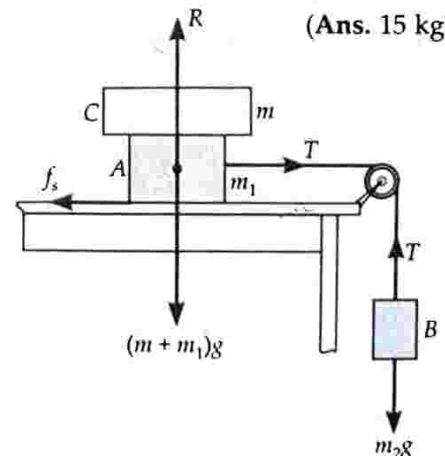

Fig. 5.79

### ✖ HINTS

1. Limiting friction,  $f = \mu mg = 0.6 \times 1 \times 9.8 = 5.88 \text{ N}$

Applied force,  $F = ma = 1 \times 5 = 5 \text{ N}$

As  $F < f$ , so force of friction =  $5 \text{ N}$ .

2. Here  $\sin \theta = \frac{5}{13} \therefore \cos \theta = \sqrt{1 - \left(\frac{5}{13}\right)^2} = \frac{12}{13}$

$$\mu = \tan \theta = \frac{\sin \theta}{\cos \theta} = \frac{5}{12} = 0.4167.$$

3. Here  $R = \text{Weight of scooter} = 120 \text{ kg f}$ ,  $\mu = 0.4$

$$\therefore f = \mu R = 0.4 \times 120 = 48 \text{ kg f.}$$

4. Here  $u = v$ ,  $v = 0$ ,  $a = -\mu g$ ,  $s = ?$

$$\text{As } v^2 - u^2 = 2as \quad \therefore 0 - v^2 = 2(-\mu g)s$$

$$\text{or } s = \frac{v^2}{2g}$$

5. Here  $a = \mu g = 0.4 \times 9.8 = 3.92 \text{ ms}^{-2}$

$$\text{Now } u = 10 \text{ ms}^{-1}, v = 0, s = ?, a = -3.92 \text{ ms}^{-2}$$

$$\therefore 0^2 - 10^2 = 2 \times (-3.92) \times s \text{ or } s = 12.75 \text{ m.}$$

6. Here  $u = 7 \text{ ms}^{-1}$ ,  $v = 0$ ,  $s = 10 \text{ m}$

$$\text{As } v^2 - u^2 = 2as \quad \therefore 0 - 7^2 = 2a \times 10$$

$$\text{or } a = -2.45 \text{ ms}^{-2} = -\frac{9.8}{4} \text{ ms}^{-2} = -\frac{g}{4}$$

Total resistance to motion

$$= -ma = \frac{1}{4} \times mg = \frac{1}{4} \times \text{weight of the car.}$$

7. Here  $v = 50 \text{ ms}^{-1}$ ,  $\mu = 0.05$ ,  $m = 3 \times 10^5 \text{ kg}$

Friction,

$$f = \mu R = \mu mg = 0.05 \times 3 \times 10^5 \times 10 = 1.5 \times 10^5 \text{ N}$$

Power,

$$P = f \times v = 1.5 \times 10^5 \times 50 = 75 \times 10^5 \text{ W} = 7500 \text{ kW.}$$

8. Here  $m = 1000 \text{ quintals}$ ,  $v = 72 \text{ kmh}^{-1} = 20 \text{ ms}^{-1}$

Total frictional resistance,

$$f = 50 \times 1000 \text{ g wt} = 50 \text{ kg wt} = 50 \times 9.8 \text{ N}$$

$$\text{Power, } P = f \times v = 50 \times 9.8 \times 20 = 9800 \text{ W.}$$

9. Normal load on rear wheel

$$= \frac{1}{2} Mg = R \text{ (Normal reaction)}$$

Maximum sustainable frictional force

$$f_s^{\max} = \mu_s R = \frac{1}{2} \mu_s Mg$$

Acceleration of the automobile

$$= \frac{F}{M} = \frac{f_s^{\max}}{M} = \frac{1}{2} \mu_s g$$

$$\text{As } v = u + at = 0 + at$$

$$\therefore t = \frac{v}{a} = \frac{2v}{\mu_s g} = \frac{2 \times 100 \times 5}{0.5 \times 9.8 \times 18} = 11.3 \text{ s.}$$

11. Here  $u = 3 \text{ ms}^{-1}$ ,  $v = 0$ ,  $a = -\mu g = -0.5 \times 9.8 \text{ ms}^{-2}$

$$\text{As } v^2 - u^2 = 2as \quad \therefore 0 - 3^2 = -2 \times 0.5 \times 9.8 \times s$$

$$\text{or } s = \frac{9}{9.8} = 0.92 \text{ m.}$$

12. Here  $u = 72 \text{ kmh}^{-1} = 20 \text{ ms}^{-1}$ ,  $\mu_s = 0.5$

$$f_s^{\max} = \mu_s R = \mu_s mg = 0.5 mg$$

$$\text{Retardation} = \frac{f_s^{\max}}{m} = \frac{0.5 mg}{m} = 0.05 g$$

$$\text{As } v = u + at \quad \therefore 0 = 20 - 0.5 gt$$

$$\text{or } t = \frac{20}{0.5 g} = \frac{20}{0.5 \times 9.8} = 4.08 \text{ s.}$$

13. Net force on each body is zero.

$$\text{For A: } R = (m + m_1) g$$

$$\text{and } T = f_s = \mu R = \mu (m + m_1) g$$

$$\text{For B: } T = m_2 g \text{ or } \mu (m + m_1) g = m_2 g$$

$$\therefore m = \frac{m_2 - \mu m_1}{\mu} = \frac{m_2}{\mu} - m_1$$

$$= \frac{5}{0.2} - 10 = 25 - 10 = 15 \text{ kg.}$$

## 5.28 WORK DONE AGAINST FRICTION

58. Find an expression for the work done in sliding a body over a rough horizontal surface.

**Work done in sliding a body over a horizontal surface.** Consider a body of weight  $mg$  resting on a rough horizontal surface, as shown in Fig. 5.80. The weight  $mg$  is balanced by the normal reaction  $R$  of the horizontal surface.

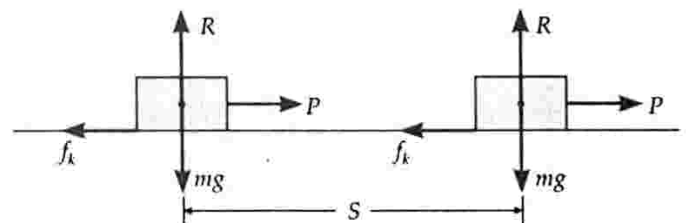

**Fig. 5.80** Work done in sliding a body over horizontal surface.

Suppose a force  $P$  is applied horizontally so that the body just begins to slide. Let  $f_k$  be the kinetic friction.

Work done against friction in moving the body through distance  $S$  will be

$$W = f_k \times S$$

$$\text{But } f_k = \mu_k R = \mu_k \cdot mg$$

$$\therefore W = \mu_k \cdot mg \cdot S.$$

59. Find an expression for the work done against friction when a body is made to slide up an inclined plane.

**Work done in moving a body up an inclined plane.** Suppose a body of weight  $mg$  is placed on an inclined plane, as shown Fig. 5.81. Let  $\theta$  be the angle of inclination. A force  $P$  is applied on the body so that it just begins to slide up the inclined plane.

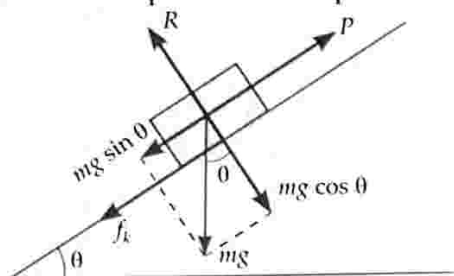

Fig. 5.81 Work done in moving a body up an inclined plane

The weight  $mg$  of the body has two components :

(i)  $mg \cos \theta$  perpendicular to the inclined plane. It balances the normal reaction  $R$ . Thus

$$R = mg \cos \theta$$

(ii)  $mg \sin \theta$  down the inclined plane.

If  $f_k$  is the kinetic friction, then the force needed to be applied upwards to just move the body up the inclined plane must be

$$P = mg \sin \theta + f_k$$

But  $f_k = \mu_k R = \mu_k mg \cos \theta$

$$\therefore P = mg \sin \theta + \mu_k mg \cos \theta = mg (\sin \theta + \mu_k \cos \theta)$$

Work done in pulling the body through distance  $S$  up the inclined plane is

$$W = P \times S = mg (\sin \theta + \mu_k \cos \theta) S.$$

60. Find an expression for the work done against friction when a body is made to slide down an inclined plane ?

**Work done in moving a body down an inclined plane.** Suppose a body of weight  $mg$  is placed on an inclined plane, as shown in Fig. 5.82. Suppose the angle of inclination  $\theta$  be less than the angle of repose. A force  $P$  is applied to just slide the body down the inclined plane.

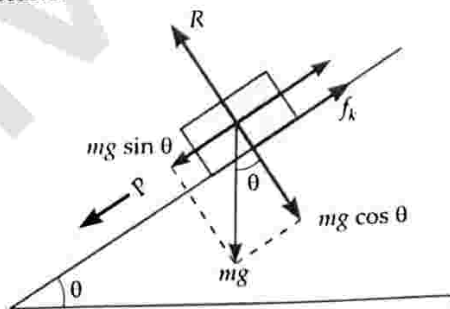

Fig. 5.82 Work done in moving a body down an inclined plane.

The weight  $mg$  of the body has two components :  
(i)  $mg \cos \theta$  perpendicular to the inclined plane. It balances the normal reaction  $R$ . Thus

$$R = mg \cos \theta$$

(ii)  $mg \sin \theta$  down the inclined plane.

The force of friction  $f_k$  acts up the inclined plane. The applied force needed to just move the body down the inclined plane must be

$$P = f_k - mg \sin \theta$$

But  $f_k = \mu_k R = \mu_k mg \cos \theta$

$$\therefore P = \mu_k mg \cos \theta - mg \sin \theta = mg (\mu_k \cos \theta - \sin \theta)$$

The work done in sliding the body through distance  $S$  down the inclined plane is

$$W = P \times S = mg (\mu_k \cos \theta - \sin \theta) S.$$

### 5.29 ACCELERATION OF A BODY SLIDING DOWN A ROUGH INCLINED PLANE

61. Derive an expression for the acceleration of a body sliding down a rough inclined plane.

**Acceleration of a body sliding down an inclined plane.** As shown in Fig. 5.83, consider a body of weight  $mg$  placed on an inclined plane. Suppose the angle of inclination  $\theta$  be greater than the angle of repose. Let  $a$  be the acceleration with which the body slides down the inclined plane.

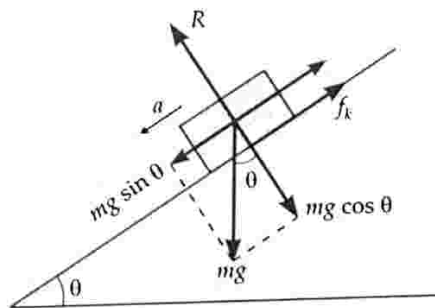

Fig. 5.83 Acceleration of a body down an inclined plane.

The weight  $mg$  has two rectangular components :  
(i)  $mg \cos \theta$  perpendicular to the inclined plane. It balances the normal reaction  $R$ . Thus

$$R = mg \cos \theta$$

(ii)  $mg \sin \theta$  down the inclined plane.

If  $f_k$  is the kinetic friction, then the net force acting down the plane is

$$F = mg \sin \theta - f_k$$

But  $f_k = \mu_k R = \mu_k mg \cos \theta$

$$\therefore ma = mg \sin \theta - \mu_k mg \cos \theta$$

Hence  $a = g (\sin \theta - \mu_k \cos \theta).$

### Examples based on Motion along Rough Inclined Plane

#### FORMULAE USED

1. For a body placed on an inclined plane of inclination  $\theta$ ,

$$\text{Normal reaction, } R = mg \cos \theta$$

$$\text{Friction, } f = \mu R = \mu mg \cos \theta$$

2. When a body moves down an inclined plane without any acceleration, net downward force needed is

$$F = mg \sin \theta - f = mg (\sin \theta - \mu \cos \theta)$$

$$\text{Work done, } W = Fs = mg (\sin \theta - \mu \cos \theta) s$$

3. When a body moves up an inclined plane without acceleration, net upward force needed is

$$F = mg \sin \theta + f = mg (\sin \theta + \mu \cos \theta)$$

$$W = mg (\sin \theta + \mu \cos \theta) s$$

4. When a body moves up an inclined plane, with acceleration  $a$ , net upward force needed is

$$F = ma + mg \sin \theta + f$$

$$= m(a + g \sin \theta + \mu g \cos \theta)$$

$$W = m(a + g \sin \theta + \mu g \cos \theta) s$$

#### UNITS USED

Forces  $F$ ,  $f$ ,  $R$  and  $mg$  are in newton, angle  $\theta$  in degree, distance  $s$  in metre, work done  $W$  in joule, coefficient of friction  $\mu$  has no units.

**EXAMPLE 60.** A box of mass 4 kg is placed on a wooden plank of length 1.5 m which is lying on the ground. The plank is lifted from one end along its length so that it becomes inclined. It is noted that when the vertical height of the top end of the plank from the ground becomes 0.5 m, the box begins to slide. Find the coefficient of friction between the box and the plank.

**Solution.** Here  $m = 4$  kg,  $AB = 1.5$  m,  $BC = 0.5$  m

Various forces acting on the box are as shown in Fig. 5.84. In equilibrium,

$$R = mg \cos \theta$$

and  $f = mg \sin \theta$

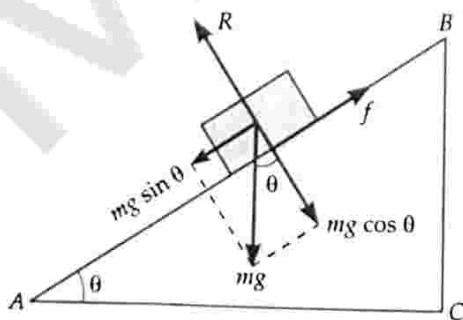

Fig. 5.84

$$\begin{aligned} \therefore \mu &= \frac{f}{R} = \frac{mg \sin \theta}{mg \cos \theta} = \tan \theta = \frac{BC}{AC} \\ &= \frac{BC}{\sqrt{AB^2 - BC^2}} = \frac{0.5}{\sqrt{(1.5)^2 - (0.5)^2}} \\ &= \frac{0.5}{\sqrt{2}} = 0.7 \times 0.5 = 0.35. \end{aligned}$$

**EXAMPLE 61.** A mass of 200 kg is resting on a rough inclined plane of  $30^\circ$ . If the coefficient of friction is  $1/\sqrt{3}$ , find the least and the greatest forces acting parallel to the plane to keep the mass in equilibrium. [Central Schools 08]

**Solution.** Here  $m = 200$  kg,  $\theta = 30^\circ$ ,  $\mu = 1/\sqrt{3}$

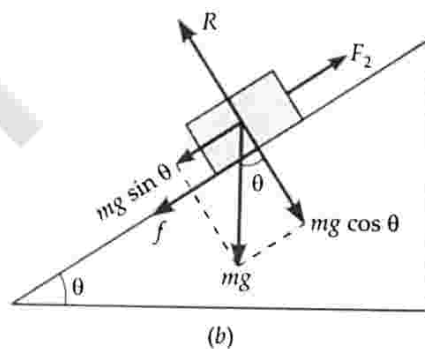
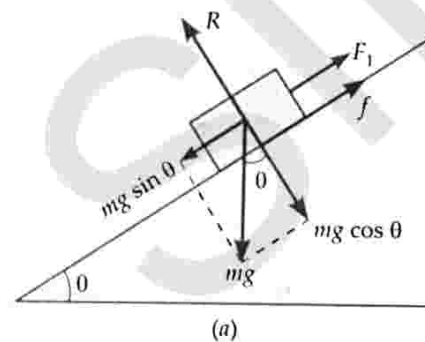

Fig. 5.85

From the above figures, force of friction is

$$\begin{aligned} f &= \mu R = \mu mg \cos \theta = \frac{1}{\sqrt{3}} \times 200 \times 9.8 \cos 30^\circ \\ &= \frac{1}{\sqrt{3}} \times 200 \times 9.8 \times \frac{\sqrt{3}}{2} = 980 \text{ N} \end{aligned}$$

Component of the weight acting down the inclined plane

$$\begin{aligned} &= mg \sin \theta = 200 \times 9.8 \sin 30^\circ \\ &= 200 \times 9.8 \times 0.5 = 980 \text{ N} \end{aligned}$$

(i) From Fig. 5.85(a), the least force required to prevent the mass from sliding down (when friction  $f$  acts upwards) is

$$F_1 = mg \sin \theta - f = 980 - 980 = 0.$$

(ii) From Fig. 5.85(b), the greatest force required to prevent the mass from sliding up (when friction  $f$  acts downwards) is

$$F_2 = mg \sin \theta + f = 980 + 980 = 1960 \text{ N.}$$

**EXAMPLE 62.** A box of mass 4 kg rests upon an inclined plane. The inclination of the plane to the horizontal is gradually increased. It is found that when the slope of the plane is 1 in 3, the box starts sliding down the plane. Given  $g = 9.8 \text{ ms}^{-2}$ .

- (i) Find the coefficient of friction between the box and the plane.
- (ii) What force applied to the box parallel to the plane will just make it move up the plane?

**Solution.** Here  $m = 4 \text{ kg}$ ,  $\sin \theta = \frac{1}{3}$ ,  $g = 9.8 \text{ ms}^{-2}$

(i) Various forces acting on the box are shown in Fig. 5.86. When the box just begins to slide, the forces are in equilibrium.

$$\begin{aligned} \therefore f &= mg \sin \theta \text{ and } R = mg \cos \theta \\ \mu &= \frac{f}{R} = \frac{mg \sin \theta}{mg \cos \theta} = \tan \theta \\ &= \frac{1}{\sqrt{3^2 - 1^2}} = \frac{1}{\sqrt{8}} = \frac{\sqrt{2}}{4} = 0.35. \end{aligned}$$

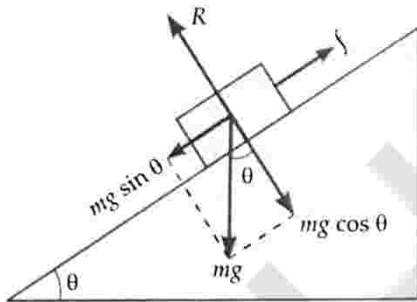

**Fig. 5.86**

(ii) When the block moves up the inclined plane, friction  $f$  acts down the plane. So minimum force needed to just move the box up the inclined plane is

$$\begin{aligned} F &= mg \sin \theta + f = mg \sin \theta + \mu R \\ &= mg (\sin \theta + \mu \cos \theta) \quad [\because R = mg \cos \theta] \\ &= 4 \times 9.8 \left( \frac{1}{3} + \frac{1}{\sqrt{8}} \cdot \frac{\sqrt{8}}{3} \right) = 4 \times 9.8 \times \frac{2}{3} = 26.13 \text{ N}. \end{aligned}$$

**EXAMPLE 63.** A block of metal of mass 50 g when placed over an inclined plane at an angle of  $15^\circ$  slides down without acceleration. If the inclination is increased by  $15^\circ$ , what would be the acceleration of the block?

**Solution.** Here  $m = 50 \text{ g} = 0.05 \text{ kg}$

Angle of repose,

$$\alpha = 15^\circ$$

$$\therefore \mu = \tan \alpha = \tan 15^\circ = 0.2679$$

New angle of inclination =  $15 + 15 = 30^\circ$

Let  $a$  be the downward acceleration produced in the block.

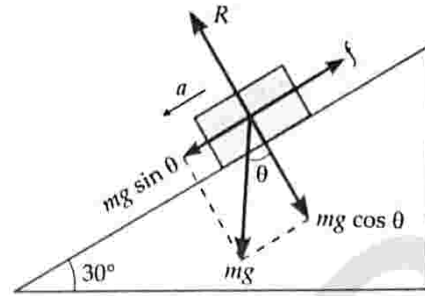

**Fig. 5.87**

Net downward force on the block is

$$\begin{aligned} F &= mg \sin \theta - f \\ ma &= mg \sin \theta - \mu mg \cos \theta \quad [\because f = \mu R = \mu mg \cos \theta] \end{aligned}$$

$$\begin{aligned} \therefore a &= g (\sin \theta - \mu \cos \theta) \\ &= 9.8 (\sin 30^\circ - 0.2679 \cos 30^\circ) \\ &= 9.8 (0.5 - 0.2679 \times 0.866) \\ &= 9.8 \times 0.2680 = 2.6 \text{ ms}^{-2}. \end{aligned}$$

**EXAMPLE 64.** When an automobile moving with a speed of  $36 \text{ kmh}^{-1}$  reaches an upward inclined road of angle  $30^\circ$ , its engine is switched off. If the coefficient of friction involved is 0.1, how much distance will the automobile move before coming to rest? Take  $g = 10 \text{ ms}^{-2}$ .

**Solution.** As shown in Fig. 5.88, when a body moves up an inclined plane, force of friction  $f$  acts down the plane. So the force against which work is needed to be done is

$$\begin{aligned} F &= mg \sin \theta + f \\ &= mg \sin \theta + \mu mg \cos \theta = mg (\sin \theta + \mu \cos \theta) \end{aligned}$$

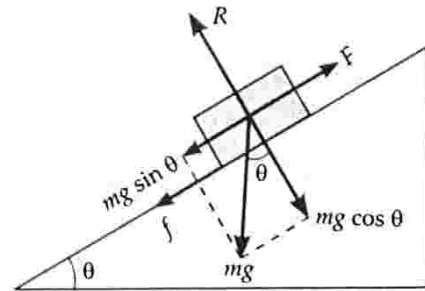

**Fig. 5.88**

If  $m$  is the mass of the automobile, retardation produced in it will be

$$\begin{aligned} a &= \frac{F}{m} = g (\sin \theta + \mu \cos \theta) \\ &= 10 (\sin 30^\circ + 0.1 \cos 30^\circ) \\ &= 10 (0.5 + 0.1 \times 0.866) = 5.866 \text{ ms}^{-2} \end{aligned}$$

Now  $u = 36 \text{ kmh}^{-1} = 10 \text{ ms}^{-1}$ ,  
 $v = 0$ ,  $a = -5.866 \text{ ms}^{-2}$ ,  $s = ?$

As  $v^2 - u^2 = 2as$

$$\therefore 0^2 - 10^2 = 2 \times (-5.866) s \text{ or } s = 8.52 \text{ m}.$$

**EXAMPLE 65.** Find the force required to move a train of 2000 quintals up an incline of 1 in 50, with an acceleration of  $2 \text{ ms}^{-2}$ , the force of friction being 0.5 newton per quintal.

**Solution.** Here  $m = 2000 \text{ quintals} = 2 \times 10^5 \text{ kg}$ ,

$$\sin \theta = \frac{1}{50}, a = 2 \text{ ms}^{-2}.$$

Force of friction = 0.5 newton per quintal

$\therefore$  Total force of friction =  $0.5 \times 2000 = 1,000 \text{ N}$

Force required against gravity in moving the train up the inclined plane

$$= mg \sin \theta = 2 \times 10^5 \times 9.8 \times \frac{1}{50} = 39,200 \text{ N}$$

Force required to produce an acceleration of  $2 \text{ ms}^{-2}$

$$= ma = 2 \times 10^5 \times 2 = 400,000 \text{ N}$$

$\therefore$  Total force required

$$= 1,000 + 39,200 + 400,000 = \mathbf{440,200 \text{ N.}}$$

**EXAMPLE 66.** An engine of mass 6.5 metric ton is going upon incline of 5 in 13 at the rate of  $9 \text{ kmh}^{-1}$ . Calculate the power of the engine if  $\mu = \frac{1}{12}$  and  $g = 9.8 \text{ ms}^{-2}$ .

**Solution.** Here

$$m = 6.5 \text{ metric ton} = 6500 \text{ kg}, g = 9.8 \text{ ms}^{-2},$$

$$v = 9 \text{ kmh}^{-1} = 9 \times \frac{5}{18} = 2.5 \text{ ms}^{-1}, \sin \theta = \frac{5}{13}$$

$$\cos \theta = \sqrt{1 - \sin^2 \theta} = \sqrt{1 - \frac{25}{169}} = \frac{12}{13}$$

Total force required against which the engine needs to work

$$F = mg \sin \theta + f = mg \sin \theta + \mu mg \cos \theta$$

$$= mg (\sin \theta + \mu \cos \theta)$$

$$= 6500 \times 9.8 \left[ \frac{5}{13} + \frac{1}{12} \times \frac{12}{13} \right] = 29400 \text{ N}$$

Power of the engine

$$= Fv = 29400 \times 2.5 = 73500 \text{ W} = \mathbf{73.5 \text{ kW.}}$$

**EXAMPLE 67.** A body of mass  $m$  is released from the top of a rough inclined plane as shown in Fig. 5.89. If the force of friction be  $f$ , then prove that the body will reach the bottom with a velocity given by  $v = \sqrt{\frac{2}{m}(mgh - fl)}$

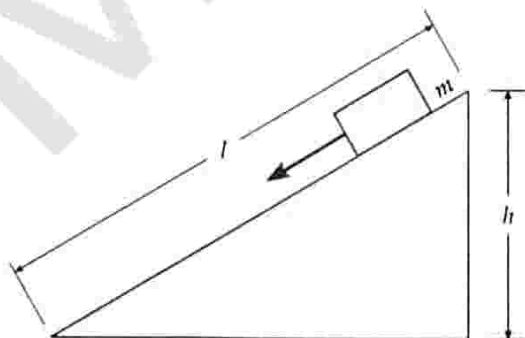

**Fig. 5.89**

**Solution.** P.E. lost by the body in reaching the bottom =  $mgh$

K.E. gained by the body in reaching the bottom

$$= \frac{1}{2} mv^2$$

$\therefore$  Net loss in energy =  $mgh - \frac{1}{2} mv^2$

Work done against friction =  $fl$

Hence  $mgh - \frac{1}{2} mv^2 = fl$

$$\text{or} \quad \frac{1}{2} mv^2 = mgh - fl$$

$$\text{or} \quad v = \sqrt{\frac{2}{m}(mgh - fl)}.$$

**EXAMPLE 68.** Two blocks of mass 2 kg and 5 kg are connected by an ideal string passing over a pulley. The block of mass 2 kg is free to slide on a surface inclined at an angle of  $30^\circ$  with the horizontal whereas 5 kg block hangs freely. Find the acceleration of the system and the tension in the string. Given  $\mu = 0.30$ .

**Solution.** The situation is shown in Fig. 5.90.

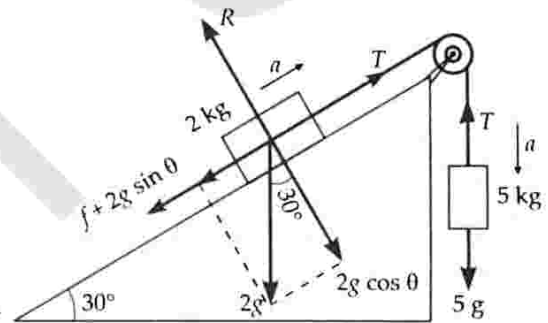

**Fig. 5.90**

Let  $a$  be the acceleration of the system in the direction as shown and  $T$  the tension in the string.

Equations of motion for 5 kg and 2 kg blocks can respectively be written as

$$5g - T = 5a \quad \dots(1)$$

$$\text{and} \quad T - 2g \sin \theta - f = 2a \quad \dots(2)$$

where  $f$  is the limiting friction and is given by

$$f = \mu R = \mu mg \cos \theta = 0.3 \times 2g \cos 30^\circ$$

Adding (1) and (2), we get

$$5g - 2g \sin \theta - f = 7a$$

$$\text{or} \quad 5g - 2g \sin 30^\circ - 0.6g \cos 30^\circ = 7a$$

$$\text{or} \quad g(5 - 2 \times 0.5 - 0.6 \times 0.866) = 7a$$

$$\text{or} \quad a = \frac{9.8 \times 3.4804}{7} = 4.87 \text{ ms}^{-2}$$

From (1),

$$T = 5g - 5a = 5(9.8 - 4.87) = 5 \times 4.93 = \mathbf{24.65 \text{ N.}}$$



**EXAMPLE 69.** A truck tows a trailer of mass 1200 kg at a speed of  $10 \text{ ms}^{-1}$  on a level road. The tension in the coupling is 1000 N. (i) What is the power expended on the trailer? (ii) Find the tension in the coupling when the truck ascends a road having an inclination of 1 in 6. Assume that the frictional resistance of the incline is the same as that on the level road.

**Solution.** On the level road, force applied by the truck is equal to the friction overcome.

$$\begin{aligned} \therefore f &= 1000 \text{ N} \\ \text{Speed of truck, } v &= 10 \text{ ms}^{-1} \\ \text{Power expended on the trailer,} \\ P &= fv = 1000 \times 10 = 10^4 \text{ W.} \end{aligned}$$

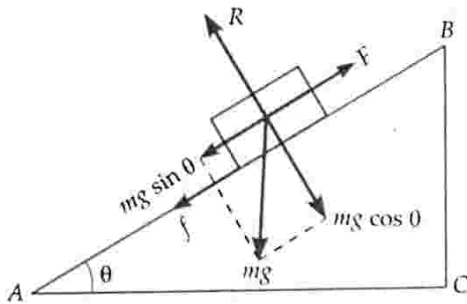

**Fig. 5.91**

As shown in Fig. 5.91, when the truck ascends a road of inclination 1 in 6 (i.e.  $\sin \theta = 1/6$ ), it overcomes not only the force of friction  $f$  but also the component  $mg \sin \theta$  of the weight of the trailer. So the tension in the coupling is

$$\begin{aligned} F &= f + mg \sin \theta = 1000 + 1200 \times 9.8 \times \frac{1}{6} \\ &= 1000 + 1960 = 2960 \text{ N.} \end{aligned}$$

**X PROBLEMS FOR PRACTICE**

1. A block of mass 2 kg rests on a plane inclined at an angle of  $30^\circ$  with the horizontal. The coefficient of friction between the block and the surface is 0.7. What will be the frictional force acting on the block? **[IIT 80]**  
(Ans. 11.9 N)
2. A block of mass 10 kg is sliding on a surface inclined at an angle of  $30^\circ$  with the horizontal. If the coefficient of friction between the block and the surface is 0.5, find the acceleration produced in the block. (Ans.  $0.657 \text{ ms}^{-2}$ )
3. Find the force required to move a train of mass  $10^5 \text{ kg}$  up an incline 1 in 50 with an acceleration of  $2 \text{ ms}^{-2}$ . Coefficient of friction between the train and the rails is 0.005. Take  $g = 10 \text{ ms}^{-2}$ .  
(Ans.  $2.25 \times 10^5 \text{ N}$ )

4. A block slides down an incline of  $30^\circ$  with an acceleration equal to  $g/4$ . Find the coefficient of kinetic friction. **[Central Schools 07]**  
(Ans.  $1/2\sqrt{3}$ )
5. A 10 kg block slides without acceleration down a rough inclined plane making an angle of  $20^\circ$  with the horizontal. Calculate the acceleration when the inclination of the plane is increased to  $30^\circ$  and the work done over a distance of 1.2 m. Take  $g = 9.8 \text{ ms}^{-2}$ . (Ans.  $1.8 \text{ ms}^{-2}$ , 21.6 J)
6. A railway engine weighing 40 metric ton is travelling along a level track at a speed of  $54 \text{ kmh}^{-1}$ . What additional power is required to maintain the same speed up an incline rising 1 in 49. Given  $\mu = 0.1$ ,  $g = 9.8 \text{ ms}^{-2}$ . (Ans. 120 kW)
7. A metal block of mass 0.5 kg is placed on a plane inclined to the horizontal at an angle of  $30^\circ$ . If the coefficient of friction is 0.2, what force must be applied (i) to just prevent the block from sliding down the inclined plane (ii) to just move the block up the inclined plane and (iii) to move it up the inclined plane with an acceleration of  $20 \text{ cms}^{-2}$ ?

(Ans. (i) 1.6 N (ii) 3.299 N (iii) 3.399 N)

8. A block 'A' of mass 14 kg moves along an inclined plane that makes an angle of  $30^\circ$  with the horizontal [Fig. 5.92]. Block A is connected to another block B of mass 14 kg by a taut massless string that runs around a frictionless, massless pulley. The block B moves downward with constant velocity. What is (i) the magnitude of the frictional force and (ii) the coefficient of kinetic friction?

(Ans. (i) 68.6 N (ii) 0.58)

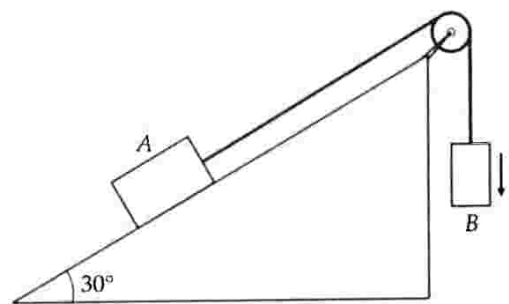

**Fig. 5.92**

9. A wooden block of mass 100 kg rests on a flat wooden floor, the coefficient of friction between the two being 0.4. The block is pulled by a rope making an angle of  $30^\circ$  with the horizontal. What is the minimum tension along the rope that just makes the block sliding? (Ans. 367.7 N)

**X HINTS**

$$\begin{aligned} 1. \text{ Here } f &= \mu R = \mu mg \cos \theta = 0.7 \times 2 \times 9.8 \cos 30^\circ \\ &= 0.7 \times 9.8 \times 0.866 = 11.9 \text{ N.} \end{aligned}$$

2. Acceleration,

$$a = g(\sin \theta - \mu_k \cos \theta) = 9.8(\sin 30^\circ - 0.5 \cos 30^\circ) = 9.8(0.5 - 0.5 \times 0.866) = 0.657 \text{ ms}^{-2}$$

3. Here  $m = 10^5 \text{ kg}$ ,  $a = 2 \text{ ms}^{-2}$ ,  $\mu = 0.005$ ,  $g = 10 \text{ ms}^{-2}$   
 $\sin \theta = 1/50$

$$\therefore \cos \theta = \sqrt{1 - \sin^2 \theta} = \sqrt{1 - \frac{1}{2500}} = \sqrt{\frac{2499}{2500}} = 1$$

$$F = ma + mg(\sin \theta + \mu \cos \theta) = 10^5 \times 2 + 10^5 \times 10 \left( \frac{1}{50} + 0.005 \times 1 \right) = 2 \times 10^5 + 0.25 \times 10^5 = 2.25 \times 10^5 \text{ N.}$$

4. Here  $mg \sin \theta - f_k = ma$  or  $mg \sin 30^\circ - f_k = mg/4$

$$\therefore f_k = mg/2 - mg/4 = mg/4 \text{ and } R = mg \cos \theta = mg \cos 30^\circ = mg(\sqrt{3}/2)$$

$$\text{Hence } \mu_k = \frac{f_k}{R} = \frac{mg/4}{mg(\sqrt{3}/2)} = \frac{1}{2\sqrt{3}}$$

5. Here  $\mu = \tan 20^\circ = 0.3647$

When the block slides down the inclined plane,

$$a = g(\sin \theta - \mu \cos \theta) = 9.8(\sin 30^\circ - 0.3647 \cos 30^\circ) = 9.8(0.5 - 0.3647 \times 0.866) = 1.8 \text{ ms}^{-2}$$

$$W = Fs = mas = 10 \times 1.8 \times 1.2 = 21.6 \text{ J.}$$

6. Here  $m = 40 \text{ metric ton} = 40 \times 10^3 \text{ kg}$ ,

$$v = 54 \text{ kmh}^{-1} = 15 \text{ ms}^{-1}$$

$$\sin \theta = \frac{1}{49}, \mu = 0.1, g = 9.8 \text{ ms}^{-2}$$

$$\cos \theta = \sqrt{1 - \sin^2 \theta} = \sqrt{1 - \left(\frac{1}{49}\right)^2} = \sqrt{\frac{2400}{2401}} = 1$$

Power required on level track,  $P_1 = f \times v = \mu mg \times v$

Power required up the incline,

$$P_2 = (mg \sin \theta + \mu mg \cos \theta) v$$

Additional power required

$$= P_2 - P_1 = [\mu mg \sin \theta + \mu mg \cos \theta - \mu mg] v$$

$$\text{or } P = (mg \sin \theta + \mu mg \times 1 - \mu mg) v$$

$$= mg \sin \theta \times v = 40 \times 10^3 \times 9.8 \times \frac{1}{49} \times 15$$

$$= 120 \times 10^3 \text{ W} = 120 \text{ kW.}$$

7. Here  $\theta = 30^\circ$ ,  $\mu = 0.2$ ,  $m = 0.5 \text{ kg}$

(i) Force needed to just prevent the block from sliding down the inclined plane,

$$F_1 = mg \sin \theta - f = mg \sin \theta - \mu mg \cos \theta$$

$$[\because f = \mu R = \mu mg \cos \theta]$$

$$= mg(\sin \theta - \mu \cos \theta)$$

$$= 0.5 \times 9.8(\sin 30^\circ - 0.2 \cos 30^\circ) = 1.6 \text{ N.}$$

(ii) Force needed to just move the block up the inclined plane,

$$F_2 = mg(\sin \theta + \mu \cos \theta)$$

$$= 0.5 \times 9.8(\sin 30^\circ + 0.2 \times \cos 30^\circ)$$

$$= 3.299 \text{ N.}$$

(iii) Force needed to move the block up the inclined plane with an acceleration of  $20 \text{ cms}^{-2}$

$$F_3 = F_2 + ma = 3.299 + 0.5 \times 20 = 3.299 + 0.1 = 3.399 \text{ N.}$$

8. (i) Various forces acting on the bodies A and B are shown in Fig. 5.93.

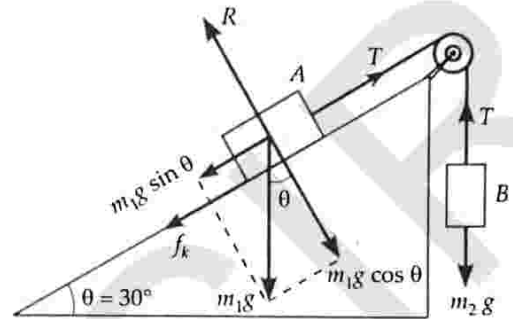

Fig. 5.93

Let  $T$  be the tension in the chord. As the block  $B$  moves downward with a constant velocity, so net force on it is zero.

$$\therefore T - m_2 g = 0 \text{ or } T_2 = m_2 g \quad \dots(i)$$

Net force on block  $A$  is also zero.

$$\therefore T - f_k - m_1 g \sin \theta = 0$$

$$\text{or } f_k = T - m_1 g \sin \theta = m_2 g - m_1 g \sin 30^\circ$$

$$= 14 \times 9.8 - 14 \times 9.8 \times \frac{1}{2} = 68.6 \text{ N.}$$

$$(ii) \mu_k = \frac{f_k}{R} = \frac{68.6}{m_1 g \cos 30^\circ} = \frac{68.6 \times 2}{14 \times 9.8 \times \sqrt{3}} = 0.58.$$

9. Various forces acting on the wooden block are as shown in Fig. 5.94. Let  $T$  be the minimum tension that just makes the block sliding. When the block just slides,

$$R = mg - T \sin 30^\circ$$

$$\text{and } T \cos 30^\circ = f = \mu R = \mu (mg - T \sin 30^\circ)$$

$$\therefore T(\cos 30^\circ + \mu \sin 30^\circ) = \mu mg$$

$$\text{or } T = \frac{\mu mg}{\cos 30^\circ + \mu \sin 30^\circ}$$

$$= \frac{0.4 \times 100 \times 9.8}{0.866 + 0.4 \times 0.5} = \frac{392}{1.060} = 367.7 \text{ N.}$$

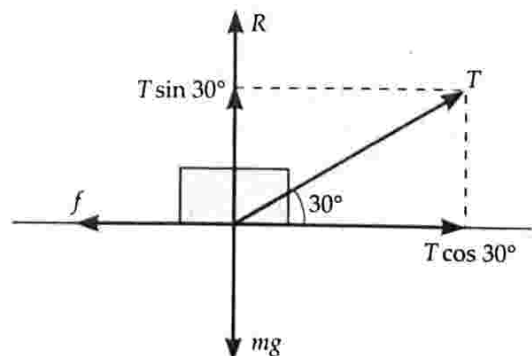

Fig. 5.94

### 5.30 ▽ FRICTION IS A NECESSARY EVIL

62. Friction is a necessary evil. Explain.

**Friction is a necessity (Advantages of friction) :**

- (i) It is due to friction between the ground and the feet that we are able to walk.
- (ii) The brakes of a vehicle cannot work without friction.
- (iii) Various parts of a machine are able to rotate because of friction between belt and pulley.
- (iv) The tyres of vehicle are made rough to increase friction.
- (v) Nails and screws join various wooden parts due to friction.
- (vi) In the absence of friction, it will not be possible to write on a paper with a pen or pencil.

**Friction is an evil (Disadvantages of friction) :**

- (i) Wear and tear of the machinery is due to friction.
- (ii) A large amount of power is wasted in overcoming friction and the efficiency of the machines decreases considerably.
- (iii) Excessive friction between rotating parts of a machine produces enough heat and causes damage to the machinery.

As friction has both advantages and disadvantages, we can say that *friction is a necessary evil*.

### 5.31 ▽ METHODS OF CHANGING FRICTION

63. Describe the various methods by which friction between two surfaces can be reduced.

**Methods of reducing friction.** Friction between two surfaces can be reduced by any of the following methods :

(i) **By polishing.** By making the surfaces in contact highly polished and smooth, the bumps and depressions get minimised and so friction is reduced considerably.

(ii) **Lubrication.** A lubricant is a substance (solid, liquid or gas) which forms a thin layer between two surfaces in contact. It fills depressions present in the surfaces of contact and hence reduces friction.

(iii) **Streamlining.** Friction due to air is considerably reduced by streamlining the shape of the body (sharp in front) moving through air. For example, jets, aeroplanes, fast moving cars, etc., have streamline shape.

(iv) **By using ball-bearings.** A ball bearing consists of two coaxial cylinders, between which steel balls are placed. The inner cylinder is fitted on the axle and the outer cylinder is fitted to the wheel. When the axle rotates in clockwise direction (say), the steel balls

rotate in the anticlockwise direction making the outer cylinder and the wheel to rotate in anticlockwise direction. As the sliding friction between the cylinders gets converted into rolling friction, so friction is considerably reduced.

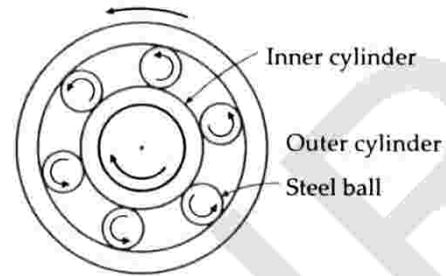

Fig. 5.95 Ball bearing.

(v) **By using antifriction alloys.** It has been found that when steel slides over an alloy such as bronze or brass, the friction is much less than when steel slides over steel. Thus friction is also reduced by lining the moving parts with alloys called antifriction alloys.

(vi) **By using air cushion.** Friction can be considerably reduced by maintaining a thin cushion of compressed air between solid surfaces in relative motion.

64. Describe some methods of increasing friction.

**Methods of increasing friction.** Some of the methods are as follows :

(i) **Treading of tyres** is done to increase friction between the road and the tyres. Moreover, synthetic rubber is preferred over the natural rubber in the manufacture of tyres because of its larger coefficient of friction with the road.

(ii) **Sand is thrown on tracks covered with snow.** This increases the force of friction between the wheels and the track and the driving becomes safer.

(iii) **On a rainy day, we throw some sand on the slippery ground.** This increases the friction between our feet and the ground. This reduces the chances of slipping.

### 5.32 ▽ PULLING A LAWN ROLLER IS EASIER THAN TO PUSH IT

65. Why is it easier to pull a lawn roller than to push it ? Explain.

**It is easier to pull a body than to push it.** As shown in Fig. 5.96, suppose a force  $F$  is applied to pull a lawn roller of weight  $W$ . The force  $F$  has two rectangular components :

- (i) Horizontal component  $F \cos \theta$  helps to move the roller forward.
- (ii) Vertical component  $F \sin \theta$  acts in the upward direction.

If  $R$  is the normal reaction, then

$$R + F \sin \theta = W$$

[Equating the vertical components]

$$R = W - F \sin \theta$$

or

Force of kinetic friction,

$$f_k = \mu_k R = \mu_k (W - F \sin \theta) \quad \dots(1)$$

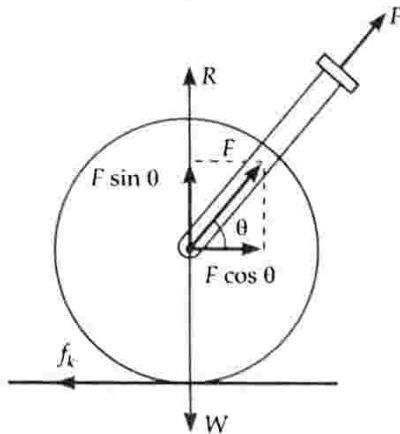

**Fig. 5.96** Pulling a roller.

As shown in Fig. 5.97, if a force  $F$  is applied to push a roller of weight  $W$ , then the normal reaction is

$$R' = W + F \sin \theta$$

Force of kinetic friction,

$$f'_k = \mu_k R' = \mu_k (W + F \sin \theta) \quad \dots(2)$$

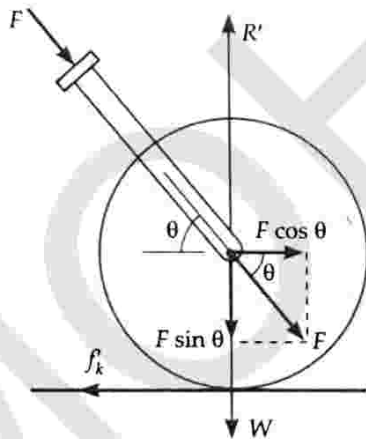

**Fig. 5.97** Pushing a roller.

Comparing (1) and (2), we find that  $f'_k > f_k$  i.e., the force of friction is more in case of push than in case of pull. So it is easier to pull a body than to push it.

### 5.33 CENTRIPETAL FORCE

66. What is centripetal force? Write an expression for it. Give some examples of centripetal force.

**Centripetal force.** A force required to make a body move along a circular path with uniform speed is called

centripetal force. It always acts along the radius and towards the centre of the circular path.

As shown in Fig. 5.98, such a force continuously deflects a particle from its straight line path to make it move along a circle.

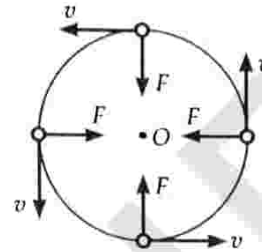

**Fig. 5.98** Centripetal force.

**Expression for centripetal force.** When a body is in uniform circular motion, its velocity changes continuously due to change in the direction of motion. Hence it undergoes an acceleration which acts radially inwards. It is called centripetal acceleration and is given by

$$a = \frac{v^2}{r} = r \omega^2 \quad [\because v = r\omega]$$

where  $v$  and  $\omega$  are the linear and angular speeds of the body and  $r$  is the radius of the circular path. According to Newton's second law, the centripetal force required to move a body of mass  $m$  along a circular path of radius  $r$  is given by

$$F = \text{mass} \times \text{centripetal acceleration}$$

$$\text{or} \quad F = \frac{mv^2}{r} = mr \omega^2$$

#### Examples of centripetal force :

- (i) For a stone rotated in a circle, the tension in the string provides the centripetal force.
- (ii) The centripetal force for the motion of the planet around the sun is provided by the gravitational force exerted by the sun on the planet.
- (iii) For a car taking a circular turn on a horizontal road, the centripetal force is provided by the force of friction between the tyres and the road.
- (iv) For an electron revolving around the nucleus, the centripetal force is provided by the electrostatic attraction between the electron and the nucleus.



#### For Your Knowledge

- ▲ Centripetal force is not a new kind of force. The material forces such as tension, gravitational force, electrical force, friction, etc., may act as the centripetal force in any circular motion.
- ▲ Centripetal force is the name given to any force that provides radial inward acceleration to a body in circular motion.

### Examples based on Centripetal Force

#### FORMULAE USED

- For a body moving along a horizontal circular path, centripetal force is

$$F = \frac{mv^2}{r} = mr\omega^2 = mr(2\pi v)^2 = mr \left( \frac{2\pi}{T} \right)^2$$

- Centrifugal force is equal to centripetal force in magnitude but acts away from the centre

#### UNITS USED

Force  $F$  is in newton, velocity  $v$  in  $\text{ms}^{-1}$ , angular frequency  $\omega$  in  $\text{rad s}^{-1}$ .

**EXAMPLE 70.** A string breaks under a load of 4.8 kg. A mass of 0.5 kg is attached to one end of the string 2 m long and is rotated in a horizontal circle. Calculate the greatest number of revolutions that the mass can make without breaking the string.

**Solution.** Here  $m = 0.5 \text{ kg}$ ,  $r = 2 \text{ m}$ ,  $g = 9.8 \text{ ms}^{-2}$ ,

The maximum tension that the string can withstand,

$$F = 4.8 \text{ kg wt} = 4.8 \times 9.8 \text{ N}$$

Let the maximum number of revolutions per second =  $v$

$$\text{Now } F = mr\omega^2 = mr(2\pi v)^2 = 4\pi^2 mr v^2$$

$$\text{or } v^2 = \frac{F}{4\pi^2 mr} = \frac{4.8 \times 9.8}{4 \times 9.87 \times 0.5 \times 2} = 1.215$$

$$\text{or } v = \sqrt{1.215} = 1.102 \text{ rps} \\ = 1.102 \times 60 = 66.13 \text{ rpm.}$$

**EXAMPLE 71.** A ball of mass 0.1 kg is suspended by a string 30 cm long. Keeping the string always taut, the ball describes a horizontal circle of radius 15 cm. Calculate the angular speed. [Delhi 06]

**Solution.** The situation is shown in Fig. 5.99.

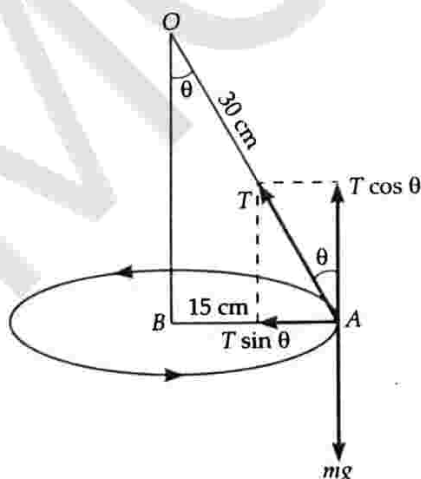

Fig. 5.99

Here  $m = 0.1 \text{ kg}$ ,  $r = 15 \text{ cm} = 0.15 \text{ m}$

Let the string make angle  $\theta$  with the vertical. Then

$$\sin \theta = \frac{AB}{OA} = \frac{15}{30} = \frac{1}{2} \quad \text{or } \theta = 30^\circ.$$

Let  $T$  be the tension in the string. Its vertical component balances the weight  $mg$  while the horizontal component  $T \sin \theta$  provides the centripetal force.

$$\therefore T \cos \theta = mg \quad \dots(i)$$

$$\text{and } T \sin \theta = mr\omega^2 \quad \dots(ii)$$

Dividing (ii) by (i), we get

$$\frac{T \sin \theta}{T \cos \theta} = \frac{mr\omega^2}{mg}$$

$$\tan \theta = \frac{r\omega^2}{g}$$

or

or

$$\omega = \sqrt{\frac{g \tan \theta}{r}} = \sqrt{\frac{9.8 \times \tan 30^\circ}{0.15}} \\ = 6.14 \text{ rad s}^{-1}.$$

#### PROBLEMS FOR PRACTICE

- A particle of mass 21 g attached to a string of 70 cm length is whirled round in a horizontal circle. If the period of revolution is 2 s, find the tension in the string. (Ans. 14520 dyne)
- A stone of mass 4 kg is attached to a string of 10 m length and is whirled in a horizontal circle. The string can withstand a maximum tension of 160 N. Calculate the maximum velocity of revolution that can be given to the stone without breaking the string. (Ans. 20  $\text{ms}^{-1}$ )
- A 100 g weight is tied at the end of a string and whirled around in a horizontal circle of radius 15 cm at the rate of 3 revolutions per second. What is the tension in the string? (Ans. 5.334 N)
- A gramophone disc rotates at 60 rpm. A coin of mass 18 g is placed at a distance of 8 cm from the centre. Calculate the centrifugal force on the coin. Take  $\pi^2 = 9.87$ . (Ans. 4105.92 dyne)
- A ball of mass 100 g is suspended by a string 40 cm long. Keeping the string taut, the ball describes a horizontal circle of radius 10 cm. Find the angular speed. (Ans. 1.59  $\text{rad s}^{-1}$ )

#### HINTS

- Here  $m = 21 \text{ g}$ ,  $r = 70 \text{ cm}$ ,  $T = 2 \text{ s}$

$$\therefore \text{Tension} = mr\omega^2 = mr \left( \frac{2\pi}{T} \right)^2$$

$$= 21 \times 70 \times \left( \frac{2 \times 22}{2 \times 7} \right)^2 = 14520 \text{ dyne.}$$

2. Here  $m = 4 \text{ kg}$ ,  $r = 10 \text{ m}$ ,  $T_{\text{max}} = 160 \text{ N}$ ,  $v = ?$

$$\text{As } T_{\text{max}} = \frac{mv_{\text{max}}^2}{r} \quad \text{or} \quad v_{\text{max}}^2 = \frac{T_{\text{max}} \times r}{m}$$

$$\therefore v_{\text{max}} = \sqrt{\frac{T_{\text{max}} \times r}{m}} = \sqrt{\frac{160 \times 10}{4}} = 20 \text{ ms}^{-1}$$

3. Here  $m = 0.1 \text{ kg}$ ,  $r = 0.15 \text{ m}$ ,  $\dot{v} = 3 \text{ rps}$

$$\omega = 2\pi\nu = 2\pi \times 3 = 6\pi \text{ rads}^{-1}$$

$$T = mr\omega^2 = 0.3 \times 0.15 \times (6\pi)^2 = 5.334 \text{ N}$$

### 5.34 CIRCULAR MOTION OF A CAR ON A LEVEL ROAD

67. Briefly explain how is a vehicle able to go round a level curved track. Determine the maximum speed with which the vehicle can negotiate this curved track safely.

**Car on a circular level road.** When a car negotiates a curved level road, the force of friction between the road and the tyres provides the centripetal force required to keep the car in motion around the curve.

As shown in Fig. 5.100, consider a car of weight  $mg$  going around a circular level road of radius  $r$  with constant speed  $v$ . While taking the turn, the tyres of the car tend to leave the road and go away from the centre of the curve. The forces of friction  $f_1$  and  $f_2$  act inward at the inner and the outer tyres respectively. If  $R_1$  and  $R_2$  are the reactions of the ground at the inner and outer tyres, then

$$f_1 = \mu R_1 \quad \text{and} \quad f_2 = \mu R_2$$

where  $\mu$  is the coefficient of friction between the tyres and the road. As the total normal reaction balances the weight of the car, therefore  $R_1 + R_2 = mg$

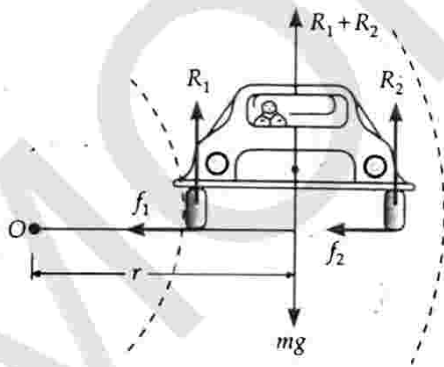

Fig. 5.100 Motion of a car on a circular level road.

Total force of friction

$$= f_1 + f_2 = \mu(R_1 + R_2) = \mu \cdot mg$$

For the car to stay on the road, the maximum force of friction must be equal to or greater than the centripetal force i.e.,

$$\mu \cdot mg \geq \frac{mv^2}{r} \quad \text{or} \quad \frac{v^2}{rg} \leq \mu \quad \text{or} \quad v^2 \leq \mu rg$$

The maximum speed with which the car can turn safely is

$$v_{\text{max}} = \sqrt{\mu rg}$$

If the speed exceeds  $v_{\text{max}}$ , the car will skid and go off the road in a circle of radius greater than  $r$ . This is because the maximum available friction is insufficient to provide the necessary centripetal force. Clearly, the maximum safe speed  $v_{\text{max}}$  depends on the radius  $r$  of the curved path and the coefficient of friction  $\mu$  between the road and the tyres.

### 5.35 CIRCULAR MOTION OF A CAR ON A BANKED ROAD

68. What do you mean by banking of a curved road? Determine the angle of banking so as to minimise the wear and tear of the tyres of a car negotiating a banked curve.

**Banking of the curved road.** The large amount of friction between the tyres and the road produces considerable wear and tear of the tyres. To avoid this, the curved road is given an inclination sloping upwards towards the outer circumference. This reduces wearing out of the tyres because the horizontal component of the normal reaction provides the necessary centripetal force.

The system of raising the outer edge of a curved road above its inner edge is called **banking of the curved road**. The angle through which the outer edge of the curved road is raised above the inner edge is called **angle of banking**.

**Circular motion of a car on a banked road.** As shown in Fig. 5.101, consider a car of weight  $mg$  going along a curved path of radius  $r$  with speed  $v$  on a road banked at an angle  $\theta$ . The forces acting on the vehicle are

1. Weight  $mg$  acting vertically downwards.
2. Normal reaction  $R$  of the road acting at an angle  $\theta$  with the vertical.
3. Force of friction  $f$  acting downwards along the inclined plane.

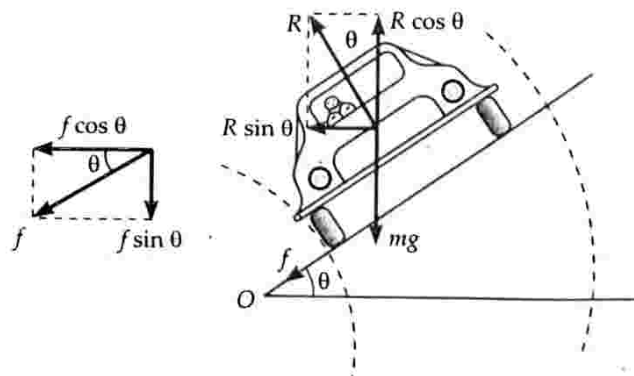

Fig. 5.101 Circular motion of a car on a banked road.

Equating the forces along horizontal and vertical directions respectively, we get

$$R \sin \theta + f \cos \theta = \frac{mv^2}{r} \quad \dots(1)$$

$$mg + f \sin \theta = R \cos \theta, \text{ where } f = \mu R$$

or  $R \cos \theta - f \sin \theta = mg \quad \dots(2)$

Dividing equation (1) by equation (2), we get

$$\frac{R \sin \theta + f \cos \theta}{R \cos \theta - f \sin \theta} = \frac{v^2}{rg}$$

Dividing numerator and denominator of L.H.S. by  $R \cos \theta$ , we get

$$\frac{\tan \theta + \frac{f}{R}}{1 - \frac{f}{R} \tan \theta} = \frac{v^2}{rg}$$

or  $\frac{\tan \theta + \mu}{1 - \mu \tan \theta} = \frac{v^2}{rg} \quad \left[ \because \mu = \frac{f}{R} \right]$

or  $v^2 = rg \left[ \frac{\mu + \tan \theta}{1 - \mu \tan \theta} \right] \text{ or } v = \sqrt{rg \cdot \frac{\mu + \tan \theta}{1 - \mu \tan \theta}}$

**Special case.** When there is no friction between the road and the tyres,  $\mu = 0$ , so that the safe limit for maximum speed is  $v = \sqrt{rg \tan \theta}$ .

The angle of banking  $\theta$  for minimum wear and tear of tyres is given by

or  $\tan \theta = \frac{v^2}{rg} \text{ or } \theta = \tan^{-1} \left( \frac{v^2}{rg} \right)$

### 5.36 ▽ BENDING OF A CYCLIST

**69.** Why does a cyclist lean inward when moving along a curved path? Determine the angle through which a cyclist bends from the vertical while negotiating a curve.

**Bending of a cyclist.** When a cyclist goes round a curved path, a centripetal force is required. The force of friction between the tyres and the road is too small to provide the necessary centripetal force. That is a why a cyclist going round a curve leans inward because then the horizontal component of the normal reaction provides the necessary centripetal force.

Suppose the cyclist bends inwards through an angle  $\theta$  from the vertical. The horizontal component  $R \sin \theta$  of the normal reaction  $R$  provides the centripetal force.

$$\therefore R \sin \theta = \frac{mv^2}{r} \quad \dots(1)$$

The vertical component  $R \cos \theta$  of the normal reaction balances the weight  $mg$  of the cycle and the cyclist.

$$\therefore R \cos \theta = mg \quad \dots(2)$$

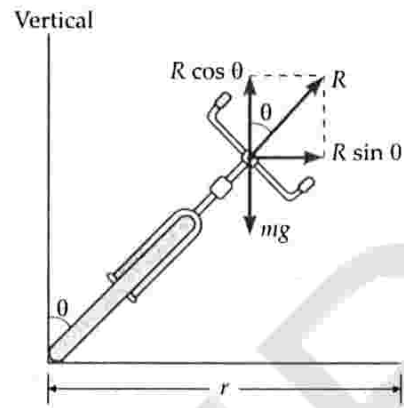

**Fig. 5.102** Bending of a cyclist.

Dividing equation (1) by equation (2), we get

$$\frac{R \sin \theta}{R \cos \theta} = \frac{mv^2/r}{mg} \text{ or } \tan \theta = \frac{v^2}{rg} \text{ or } \theta = \tan^{-1} \left( \frac{v^2}{rg} \right)$$

The angle  $\theta$  through which the cyclist bends would be greater, if

- (i) the radius of the curved path is small or the curved turn is sharp.
- (ii) the speed of the cyclist is large.

### Examples based on

#### Banking of Roads and Bending of a Cyclist

##### FORMULAE USED

1. A vehicle taking a circular turn on a level road. If  $\mu$  is the coefficient of friction between tyres and road, then the maximum velocity with which the vehicle can safely take a circular turn of radius  $r$  is given by

$$v_{\max} = \sqrt{\mu rg}$$

2. Banking of tracks (roads). The maximum velocity with which a vehicle (in the absence of friction) can negotiate a circular road of radius  $r$  and banked at an angle  $\theta$  is given by

$$v = \sqrt{rg \tan \theta}$$

When the frictional forces are also taken into account, the maximum safe velocity is given by

$$v_{\max} = \sqrt{rg \left( \frac{\mu + \tan \theta}{1 - \mu \tan \theta} \right)}$$

3. Bending of a cyclist. In order to take a circular turn of radius  $r$  with speed  $v$ , the cyclist should bend himself through an angle  $\theta$  from the vertical such that

$$\tan \theta = \frac{v^2}{rg}$$

##### UNITS USED

Velocity  $v$  is in  $\text{ms}^{-1}$ , radius  $r$  in metre, angle  $\theta$  in degrees and coefficient of friction  $\mu$  has no units.

**EXAMPLE 72.** A bend in a level road has a radius of 100 metres. Find the maximum speed which a car turning this bend may have without skidding, if the coefficient of friction between the tyres and road is 0.8. [NCERT]

**Solution.** Here  $r = 100 \text{ m}$ ,  $\mu = 0.8$ ,  $g = 9.8 \text{ ms}^{-2}$

The car will not skid if the force of friction provides the necessary centripetal force.

$$\therefore f = \mu mg = \frac{mv_{\max}^2}{r}$$

$$\text{or } v_{\max} = \sqrt{\mu rg} = \sqrt{0.8 \times 100 \times 9.8} = 28 \text{ ms}^{-1}.$$

**EXAMPLE 73.** A car of mass 1500 kg is moving with a speed of  $12.5 \text{ ms}^{-1}$  on a circular path of radius 20 m on a level road. What should be the frictional force between the car and the road so that the car does not slip? What should be the value of the coefficient of friction to attain this force?

**Solution.** Here  $m = 1500 \text{ kg}$ ,  $v = 12.5 \text{ ms}^{-1}$ ,  $r = 20 \text{ m}$

Frictional force = Required centripetal force

$$\text{or } f = \frac{mv^2}{r} = \frac{1500 \times 12.5 \times 12.5}{20} \\ = 1.172 \times 10^4 \text{ N}$$

$$\text{But } f = \mu R = \mu mg$$

$\therefore$  Coefficient of friction,

$$\mu = \frac{f}{mg} = \frac{1.172 \times 10^4}{1500 \times 9.8} = 0.8.$$

**EXAMPLE 74.** A train has to negotiate a curve of 400 m. By how much should the outer rail be raised with respect to the inner rail for a speed of  $48 \text{ kmh}^{-1}$ ? The distance between the rails is 1 m. [NCERT]

**Solution:** Here

$$v = 48 \text{ kmh}^{-1} = \frac{48 \times 1000}{3600} = \frac{40}{3} \text{ ms}^{-1}$$

$$r = 400 \text{ m}, l = 1 \text{ m}$$

Let  $h$  be the height through which the outer rail must be raised with respect to the inner rail, as shown in Fig. 5.103. If  $\theta$  is the angle of banking, then

$$\sin \theta = \frac{h}{l}$$

For a small value of  $\theta$ ,

$$\sin \theta \approx \tan \theta$$

$$\text{or } \frac{h}{l} = \frac{v^2}{rg}$$

$$\text{or } h = \frac{v^2 l}{rg}$$

$$= \frac{(40/3)^2 \times 1}{400 \times 9.8} = 0.0454 \text{ m}.$$

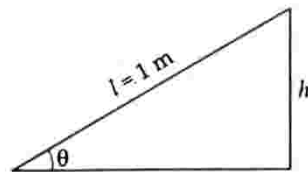

Fig. 5.103

**EXAMPLE 75.** Calculate the angle through which a cyclist bends from the vertical when he crosses a circular path of 34.3 m in circumference in  $\sqrt{22}$  s. Take  $g = 9.8 \text{ ms}^{-2}$ .

**Solution.** Radius of circular path,

$$r = \frac{\text{Circumference}}{2\pi} = \frac{34.3 \times 7}{2 \times 22} \text{ m}$$

$$\text{Velocity, } v = \frac{\text{Length of path}}{\text{Time taken}} = \frac{34.3}{\sqrt{22}} \text{ ms}^{-1}$$

$$\tan \theta = \frac{v^2}{rg} = \left( \frac{34.3}{\sqrt{22}} \right)^2 \times \frac{2 \times 22}{34.3 \times 7} \times \frac{1}{9.8} = 1$$

$\therefore$  Angle through which the cyclist bends from the vertical,  $\theta = 45^\circ$ .

**EXAMPLE 76.** A cyclist speeding at  $18 \text{ kmh}^{-1}$  on a level road takes a sharp circular turn of radius 3 m without reducing the speed and without bending towards the centre of the circular path. The coefficient of static friction between the tyres and the road is 0.1. Will the cyclist slip while taking the turn? [NCERT]

**Solution.** On a level road, force of friction alone provides centripetal force for going along the circular turn.

$$\text{As } \tan \theta = \mu = \frac{v^2}{rg}$$

Therefore, the maximum safe speed is given by

$$v_{\max} = \sqrt{\mu rg} = \sqrt{0.1 \times 3 \times 9.8} = \sqrt{2.94} = 1.715 \text{ ms}^{-1}$$

$$\text{Actual speed, } v = 18 \text{ kmh}^{-1} = 5 \text{ ms}^{-1}$$

As the actual speed is greater than the maximum safe speed, so the cyclist will slip while taking the turn.

**EXAMPLE 77.** A circular race track of radius 300 m is banked at an angle of  $15^\circ$ . If the coefficient of friction between the wheels of a race car and the road is 0.2, what is the

- (i) optimum speed of the race car to avoid wear and tear on its tyres, and
- (ii) maximum permissible speed to avoid slipping?

[NCERT]

**Solution.** Given  $r = 300 \text{ m}$ ,  $\theta = 15^\circ$ ,  $\mu_s = 0.2$

(i) The optimum speed of the race car will be

$$v_0 = \sqrt{rg \tan \theta} = \sqrt{300 \times 9.8 \times \tan 15^\circ} \\ = \sqrt{300 \times 9.8 \times 0.2679} = 28.1 \text{ ms}^{-1}.$$

(ii) The maximum permissible speed of race car will be

$$v_{\max} = \sqrt{rg \frac{\mu_s + \tan \theta}{1 - \mu_s \tan \theta}} \\ = \sqrt{300 \times 9.8 \times \frac{0.2 + 0.2679}{1 - 0.2 \times 0.2679}} \\ = 38.1 \text{ ms}^{-1}.$$



**EXAMPLE 78.** A car is speeding on a horizontal road curving round with a radius 60 m. The coefficient of friction between the wheels and the road is 0.5. The height of centre of gravity of the car from the road level is 0.3 m and the distance between the wheels is 0.8 m. Calculate the maximum safe velocity for the vehicle to negotiate the curve. Will the vehicle skid or topple if this velocity is exceeded ?

**Solution.** Here  $r = 60$  m,  $\mu = 0.5$ ,  $h = 0.3$  m

Distance of any wheel from the vertical line passing through CG of the car,

$$b = \frac{0.8}{2} = 0.4 \text{ m}$$

As  $\tan \theta = \frac{v^2}{rg} \quad \therefore v = \sqrt{rg \tan \theta}$

For skidding,

$$\tan \theta = \mu$$

$$\therefore v_s = \sqrt{\mu rg} = \sqrt{0.5 \times 60 \times 9.8} = 17.15 \text{ ms}^{-1}$$

For toppling,

$$\tan \theta = \frac{b}{h}$$

$$\therefore v_t = \sqrt{\frac{brg}{h}} = \sqrt{\frac{0.4 \times 60 \times 9.8}{0.3}} = 28 \text{ ms}^{-1}$$

Thus the maximum safe velocity for the car to negotiate the curve is  $17.15 \text{ ms}^{-1}$ . When the velocity exceeds this value, the car skids until it topples at  $v = 28 \text{ ms}^{-1}$ .

**EXAMPLE 79.** An electric bulb suspended from the roof of a railway train by a flexible wire shifts through an angle of  $19^\circ 48'$ , when the train goes horizontally round a curved path of 200 m radius. Find the speed of the train.

**Solution.** Various forces acting on the bulb are shown in Fig. 5.104. Resolving the forces along the length and perpendicular to the wire, we get

$$mg \sin \theta = \frac{mv^2}{r} \cdot \cos \theta$$

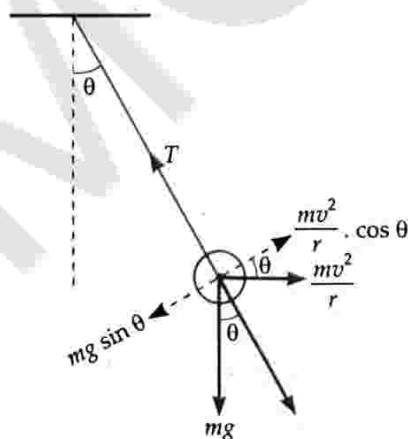

Fig. 5.104

or  $\tan \theta = \frac{v^2}{rg}$   
 or  $v = \sqrt{rg \tan \theta} = \sqrt{200 \times 9.8 \times \tan 19^\circ 48'}$   
 $= \sqrt{200 \times 9.8 \times 0.3600} = \sqrt{705.6}$   
 $= 26.56 \text{ ms}^{-1}$ .

**PROBLEMS FOR PRACTICE**

- Find the maximum speed at which a car can take turn round a curve of 30 m radius on a level road if the coefficient of friction between the tyres and the road is 0.4. Take  $g = 10 \text{ ms}^{-2}$ . [IIT 86, Roorkee 86] (Ans.  $11 \text{ ms}^{-1}$ )
- What should be the coefficient of friction between the tyres and the road, when a car travelling at  $60 \text{ km h}^{-1}$  makes a level turn of radius 40 m ? (Ans. 0.71)
- The mass of a bicycle rider along with the bicycle is 100 kg. He wants to cross over a circular turn of radius 100 m with a speed of  $10 \text{ ms}^{-1}$ . If the coefficient of friction between the tyres and the road is 0.6, will the rider be able to cross the turn ? Take  $g = 10 \text{ ms}^{-2}$ . (Ans. Yes)
- A cyclist riding at a speed of  $14\sqrt{3} \text{ ms}^{-1}$  takes a turn around a circular road of radius  $20\sqrt{3} \text{ m}$ . What is the inclination to the vertical ? (Ans.  $60^\circ$ )
- A cyclist speeding at  $6 \text{ ms}^{-1}$  in a circle of 18 m radius makes an angle  $\theta$  with the vertical. Calculate  $\theta$ . Also determine the minimum possible value of the coefficient of friction between the tyres and the ground. (Ans.  $11^\circ 32'$ , 0.2041)
- A motor cyclist goes round a circular race course of diameter 320 m at  $144 \text{ km h}^{-1}$ . How far from the vertical must he lean inwards to keep his balance ? Take  $g = 10 \text{ ms}^{-2}$ . (Ans.  $45^\circ$ )
- An aeroplane travelling at a speed of  $500 \text{ km h}^{-1}$  tilts at an angle of  $30^\circ$  as it makes a turn. What is the radius of the curve ? (Ans.  $3.41 \times 10^3 \text{ m}$ )
- For traffic moving at  $60 \text{ km h}^{-1}$ , if the radius of the curve is 0.1 km, what is the correct angle of banking of the road ? Take  $g = 10 \text{ ms}^{-2}$ . (Ans.  $15.5^\circ$ )
- A railway carriage has its CG at a height of 1 m above the rails which are 1 m apart. Calculate the maximum safe speed at which it can travel round an unbanked curve of radius 80 m. (Ans.  $19.8 \text{ ms}^{-1}$ )
- A curve in a road forms an arc of radius 800 m. If the road is 19.6 m wide and outer edge is 1 m higher than the inner edge, calculate the speed for which it is banked. (Ans.  $20 \text{ ms}^{-1}$ )

11. A train has to negotiate a curve of radius 400 m. By how much should the outer rail be raised with respect to the inner rail for a speed of  $48 \text{ kmh}^{-1}$ ? The distance between the rails is 1 m. (Ans. 0.0454 m)
12. A 2000 kg car has to go over a turn whose radius is 750 m and the angle of slope is  $5^\circ$ . The coefficient of friction between the wheels and the road is 0.5. What should be the maximum speed of the car so that it may go over the turn without slipping? (Ans.  $67.2 \text{ ms}^{-1}$ )

**X HINTS**

2. Here  $v = 60 \text{ kmh}^{-1} = \frac{60 \times 5}{18} = \frac{50}{3} \text{ ms}^{-1}$ ,  $r = 40 \text{ m}$

$\therefore \mu = \frac{v^2}{rg} = \frac{2500}{9 \times 40 \times 9.8} = 0.71$ .

3. Required centripetal force  
 $= \frac{mv^2}{r} = \frac{100 \times 10 \times 10}{100} = 100 \text{ N}$

Available frictional force  
 $= \mu mg = 0.6 \times 100 \times 10 = 600 \text{ N}$

As the available frictional force is greater than the required centripetal force, so the rider will be able to cross the turn.

5. Here  $v = 6 \text{ ms}^{-1}$ ,  $r = 18 \text{ m}$ ,  $g = 9.8 \text{ ms}^{-2}$   
 $\therefore \tan \theta = \frac{v^2}{rg} = \frac{6 \times 6}{18 \times 9.8} = 0.2041$  or  $\theta = 11^\circ 32'$ .

Also  $\mu = \tan \theta = \frac{v^2}{rg} = 0.2041$ .

8. Here  $v = 60 \text{ kmh}^{-1} = \frac{50}{3} \text{ ms}^{-1}$ ,  
 $r = 0.1 \text{ km} = 100 \text{ m}$ ,  $g = 10 \text{ ms}^{-2}$   
 $\tan \theta = \frac{v^2}{rg} = \frac{2500}{9 \times 100 \times 10} = \frac{5}{18} \therefore \theta = 15.5^\circ$ .

9. Here  $r = 80 \text{ m}$ ,  $h = 1 \text{ m}$ ,  $b = \frac{1}{2} = 0.5 \text{ m}$ ,  $g = 9.8 \text{ ms}^{-2}$   
 $\tan \theta = \frac{v^2}{rg}$

For maximum safe speed,  $\tan \theta = \frac{b}{h}$

$\therefore \frac{v^2}{rg} = \frac{b}{h}$

or  $v = \sqrt{\frac{brg}{h}} = \sqrt{\frac{0.5 \times 80 \times 9.8}{1}} = \sqrt{392} = 19.8 \text{ ms}^{-1}$ .

10. For small  $\theta$ ,  $\tan \theta \approx \sin \theta$  or  $\frac{v^2}{rg} = \frac{h}{l}$

$\therefore v = \sqrt{\frac{hrg}{l}} = \sqrt{\frac{1 \times 800 \times 9.8}{19.6}} = \sqrt{400} = 20 \text{ ms}^{-1}$ .

11. From the above problem, we have

$h = \frac{v^2 l}{rg} = \left(\frac{40}{3}\right)^2 \times \frac{1}{400 \times 9.8} = 0.0454 \text{ m}$ .

**5.37 MOTION IN A VERTICAL CIRCLE\***

70. A body tied to one end of a string is made to revolve in a vertical circle. Derive the expression for the velocity of the body and tension in the string at any point. Hence find (a) tension at the bottom and the top of the circle (b) minimum velocity at the lowest point so that it is just able to loop the loop and (c) the minimum velocity at the top.

**Motion in a vertical circle.** Consider a body of mass  $m$  tied to the one end of a string and rotating in a vertical circle of radius  $r$ , as shown in Fig. 5.105.

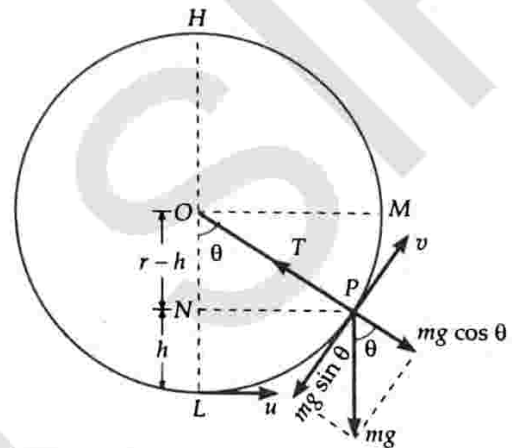

**Fig. 5.105** Motion in a vertical circle.

**Velocity at any point.** Suppose the body passes through lowest point  $L$  with velocity  $u$  and through any point  $P$  with velocity  $v$ . In moving from  $L$  to  $P$ , it has moved up through a vertical height  $LN = h$ .

According to the law of conservation of energy,

$(\text{K.E.} + \text{P.E.}) \text{ at } L = (\text{K.E.} + \text{P.E.}) \text{ at } P$

or  $\frac{1}{2} mu^2 + 0 = \frac{1}{2} mv^2 + mgh$

or  $u^2 = v^2 + 2gh$

or  $v^2 = u^2 - 2gh$  ... (1)

or  $v = \sqrt{u^2 - 2gh}$

This equation gives velocity  $v$  of the body at any point.

**Tension along the string at any point.** The forces acting on the body at point  $P$  are

(i) Weight  $mg$  acting vertically downwards.

(ii) Tension  $T$  along the string.

The component  $mg \cos \theta$  of the weight along the string acts opposite to  $T$ , so that the net centripetal force is

$T - mg \cos \theta = \frac{mv^2}{r}$

or  $T = mg \cos \theta + \frac{mv^2}{r}$  ... (2)

From right angled  $\Delta OPN$ ,

$$\cos \theta = \frac{ON}{OP} = \frac{r-h}{r} \quad \dots(3)$$

Using equations (1) and (3), equation (2) becomes

$$T = mg \frac{r-h}{r} + \frac{m}{r} (u^2 - 2gh)$$

$$= \frac{m}{r} (gr - gh + u^2 - 2gh)$$

or 
$$T = \frac{m}{r} (u^2 + gr - 3gh) \quad \dots(4)$$

This equation gives tension along the string at any point of the circle.

(a) **Tension in the string at the bottom and the top.**

At the lowest point  $L$ ,  $h=0$ , hence the tension in the string is

$$T_L = \frac{m}{r} [u^2 + gr] \quad \dots(5)$$

At the highest point  $H$ ,  $h=2r$ , hence the tension in the string is

$$T_H = \frac{m}{r} (u^2 + gr - 6gr)$$

$$= \frac{m}{r} (u^2 - 5gr) \quad \dots(6)$$

Now  $T_L - T_H = \frac{m}{r} [(u^2 + gr) - (u^2 - 5gr)] = 6mg$

Thus the difference in tensions at the lowest and the highest points is equal to six times the weight of the revolving body.

(b) **Minimum velocity of projection at the lowest point for looping the loop.** The body will be able to cross the highest point  $H$  without any slackening of the string if  $T_H$  is positive i.e.,

$$T_H \geq 0 \quad \text{or} \quad \frac{m}{r} (u^2 - 5gr) \geq 0$$

or 
$$u^2 \geq 5gr \quad \text{or} \quad u \geq \sqrt{5gr}$$

Hence  $\sqrt{5gr}$  is the minimum velocity which the body must possess at the bottom of the circle so as to go round the circle completely i.e., for looping the loop.

(c) **Minimum velocity at the top.** If  $V$  is the velocity which the body possesses at highest point  $H$  in just the case of no slackening of the string, then

$$V^2 = u^2 - 2g \cdot 2r$$

$[\because h=2r, \text{ at the highest point}]$

$$= 5gr - 4gr \quad [\because u = \sqrt{5gr}]$$

or 
$$V = \sqrt{gr}$$

This gives the minimum or *critical velocity* at the highest point.

**71.** For a body in motion in a vertical circle, deduce the conditions for (i) oscillation of the body about the lowest point and (ii) the body to leave the circular path.

**Condition for oscillation.** If  $u < \sqrt{5gr}$ , the body will either oscillate about the lowest point  $L$  or will leave its circular path.

Suppose the velocity of the body becomes zero at height  $h_1$ . As

$$v^2 = u^2 - 2gh$$

$$\therefore 0^2 = u^2 - 2gh_1 \quad \text{or} \quad h_1 = \frac{u^2}{2g}$$

Suppose the tension in the string becomes zero at height  $h_2$ . As

$$T = \frac{m}{r} (u^2 + gr - 3gh)$$

$$\therefore 0 = \frac{m}{r} (u^2 + gr - 3gh_2) \quad \text{or} \quad h_2 = \frac{u^2 + gr}{3g}$$

The body will oscillate if its velocity becomes zero earlier than the tension, i.e.,

$$h_1 < h_2 \quad \text{or} \quad \frac{u^2}{2g} < \frac{u^2 + gr}{3g}$$

or  $3u^2 < 2u^2 + 2gr$  or  $u^2 < 2gr$  or  $u < \sqrt{2gr}$

Hence the body will oscillate about the lowest point of the vertical circle if  $u < \sqrt{2gr}$ . If  $u = \sqrt{2gr}$ , the path of oscillation will be a semicircle.

**Condition for the body to leave the circle.** For this to happen, the tension in the string should become zero earlier than the velocity i.e.,

$$h_2 < h_1$$

or 
$$\frac{u^2 + gr}{3g} < \frac{u^2}{2g} \quad \text{or} \quad u > \sqrt{2gr}$$

Hence if  $\sqrt{2gr} < v_L < \sqrt{5gr}$ , the body leaves the circle somewhere between  $M$  and  $H$ , follows a parabolic path for a short while and then rejoins the circular path.

**For Your Knowledge**

▲ For a body looping the loop, the following conditions hold good :

$$v_L \geq \sqrt{gr}, \quad v_M \geq \sqrt{3gr}, \quad v_H \geq \sqrt{gr}$$

and  $T_L \geq \sqrt{6mg}, \quad T_M \geq \sqrt{3mg}, \quad T_H \geq 0.$

▲ Even if a body is projected with a minimum velocity of  $\sqrt{5gr}$  from the lowest point, its velocity at the highest point will be  $\sqrt{gr}$  and not zero.

▲ The body will oscillate about the lowest point of the vertical circle if  $v < \sqrt{2gr}$ .

▲ For the body to leave the circle,  $\sqrt{2gr} < v_L < \sqrt{5gr}$ .

▲  $T_L - T_H = 6 \times$  Weight of the body.

### Examples based on Motion in a Vertical Circle

#### FORMULAE USED

1. Velocity of the body at any point at a height  $h$  from the lowest point,

$$v = \sqrt{u^2 - 2gh}$$

2. Tension in the string at any point,

$$T = \frac{m}{r}(u^2 - 3gh + gr)$$

3. Tension at the lowest point,

$$T_L = \frac{m}{r}(u^2 + gr)$$

4. Tension at the highest point,

$$T_H = \frac{m}{r}(u^2 - 5gr)$$

5. Difference in tensions at the highest and lowest points,

$$T_L - T_H = 6mg$$

6. Minimum velocity at the lowest point for looping the vertical loop,

$$v_L = \sqrt{5gr}$$

7. Velocity at the highest point for looping the loop,

$$v_H = \sqrt{gr}$$

#### UNITS USED

- Radius  $r$  and height  $h$  are in metre, velocities  $u$  and  $v$  are in  $\text{ms}^{-1}$ , tensions  $T$ ,  $T_L$  and  $T_H$  are in newton.

**EXAMPLE 80.** One end of a string of length 1.5 m is tied to a stone of mass 0.4 kg and the other end to a small pivot on a smooth vertical board. What is the minimum speed of the stone required at its lower-most point so that the string does not slack at any point in its motion along the vertical circle?

[NCERT]

**Solution.** Here  $m = 0.4$  kg,  $r = 1.5$  m,  $g = 9.8$   $\text{ms}^{-2}$

The minimum speed required at the lowermost point so that the string does not slack is given by

$$v_{\min} = \sqrt{5gr} = \sqrt{5 \times 9.8 \times 1.5} = 8.57 \text{ ms}^{-1}$$

**EXAMPLE 81.** A body weighing 0.4 kg is whirled in a vertical circle making 2 revolutions per second. If the radius of the circle is 1.2 m find the tension in the string, when body is (i) at the bottom of the circle, (ii) at the top of the circle.

[NCERT]

**Solution.** Here  $m = 0.4$  kg,  $r = 1.2$  m,  $v = 2$  rps

Angular speed,  $\omega = 2\pi v = 2\pi \times 2 = 4\pi$   $\text{rad s}^{-1}$

(i) When body is at bottom of the circle. Let  $T$  be tension in the string. Then

$$T_1 - mg = \text{Centripetal force} = mr\omega^2$$

$$\begin{aligned} \text{or } T_1 &= m(r\omega^2 + g) = 0.4 [1.2 \times (4\pi)^2 + 9.8] \\ &= 0.4 [1.2 \times 16 \times 9.87 + 9.8] \\ &= 0.4 [189.5 + 9.8] = 79.32 \text{ N.} \end{aligned}$$

(ii) When the body is at the top of the circle. Let  $T_2$  be the tension in the string. Then

$$\begin{aligned} T_2 + mg &= \text{Centripetal force} = mr\omega^2 \\ \text{or } T_2 &= m(r\omega^2 - g) = 0.4 [1.2 \times (4\pi)^2 - 9.8] \\ &= 0.4 [189.5 - 9.8] = 71.88 \text{ N.} \end{aligned}$$

**EXAMPLE 82.** A bucket containing water is tied to one end of a rope of length 2.5 m and rotated about the other end in a vertical circle in such a way that the water in it does not spill. What is the minimum velocity of the bucket at which this happens and how many rotations per minute is it making then? Take  $g = 10$   $\text{ms}^{-2}$ .

**Solution.** Water in the bucket will not spill if the centripetal force is equal to the weight of water.

$$\frac{mv^2}{r} = mg \quad \text{or } v = \sqrt{rg}$$

$$\text{But } r = 2.5 \text{ m, } g = 10 \text{ ms}^{-2}$$

$$\therefore v = \sqrt{2.5 \times 10} = 5 \text{ ms}^{-1}$$

$$\text{Angular speed, } \omega = \frac{v}{r} = \frac{5}{2.5} = 2 \text{ rads}^{-1}$$

$$\text{Frequency of rotation, } \nu = \frac{\omega}{2\pi} = \frac{2}{2\pi} \text{ rps} = \frac{60}{\pi} \text{ rpm.}$$

**EXAMPLE 83.** A stone of mass 0.3 g is tied to one end of a string 0.8 m long and rotated in a vertical circle. At what speed of the ball will the tension in the string be zero at the highest point of the circle? What would be the tension at the lowest point in this case? Given  $g = 9.8$   $\text{ms}^{-2}$ .

**Solution.** When tension is zero at the highest point, speed is minimum. It is given by

$$v_H = \sqrt{gr} = \sqrt{9.8 \times 0.8} = 2.8 \text{ ms}^{-1}$$

$$\text{As } T_L - T_H = 6mg$$

$$\therefore T_L = 6 \times 0.3 \times 9.8 - 0 = 17.64 \text{ N.}$$

**EXAMPLE 84.** In a circus, the diameter of globe of death is 20 m. From what minimum height must a cyclist start in order to go round the globe successfully?

**Solution.** When the cyclist rolls down the incline,

Loss in P.E. = Gain in K.E.

$$mgh = \frac{1}{2}mv^2$$

$$\therefore \text{Velocity gained, } v = \sqrt{2gh}$$

For looping the loop, the minimum velocity at the lowest point should be  $\sqrt{5gr}$ .

$$\therefore \sqrt{2gh} = \sqrt{5gr}$$

$$\text{or } h = \frac{5}{2}r = \frac{5}{2} \times 10 = 25 \text{ m.}$$

[ $\therefore$  Diameter = 20 m]

**EXAMPLE 8.5.** An aeroplane flying in the sky dives, with a speed of  $360 \text{ kmh}^{-1}$  in a vertical circle of radius 200 m. The weight of the pilot sitting in it is 75 kg. Calculate the force with which the pilot presses his seat when the aeroplane is (i) at the highest position and (ii) at the lowest position of the circle. Take  $g = 10 \text{ ms}^{-2}$ .

**Solution.** As shown in Fig. 5.106, let  $R_1$  and  $R_2$  be the normal reactions at highest and lowest positions of the vertical circle.

(i) At the highest position. Here the net force  $R_1 + mg$  provides the centripetal force  $mv^2/r$ .

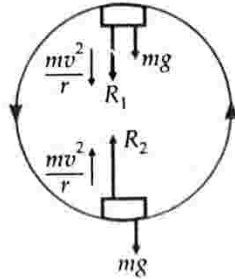

Fig. 5.106

$$\therefore R_1 + mg = \frac{mv^2}{r}$$

or 
$$R_1 = m \left( \frac{v^2}{r} - g \right)$$

But  $m = 75 \text{ kg}$ ,  $v = 36 \text{ kmh}^{-1} = 100 \text{ ms}^{-1}$ ,  
 $r = 200 \text{ m}$ ,  $g = 10 \text{ ms}^{-2}$

$$\therefore R_1 = 75 \left[ \frac{100 \times 100}{200} - 10 \right]$$

$$= 3000 \text{ N} = 300 \text{ kg wt.}$$

(ii) At the lowest position. Here the net force  $R_2 - mg$  provides the centripetal force  $mv^2/r$ .

$$\therefore R_2 - mg = \frac{mv^2}{r}$$

or 
$$R_2 = m \left[ \frac{v^2}{r} + g \right] = 75 \left[ \frac{100 \times 100}{200} + 10 \right]$$

$$= 4500 \text{ N} = 450 \text{ kg wt.}$$

**PROBLEMS FOR PRACTICE**

1. A body weighing 0.5 kg tied to a string is projected with a velocity of  $10 \text{ ms}^{-1}$ . The body starts whirling in a vertical circle. If the radius of circle is 0.8 m, find the tension in the string when the body is (i) at the top of the circle and (ii) at the bottom of the circle. [Ans. (i) 3.8 N (ii) 67.4 N]
2. A child revolves a stone of mass 0.5 kg tied to the end of a string of length 40 cm in a vertical circle. The speed of the stone at the lowest point of the circle is  $3 \text{ ms}^{-1}$ . Calculate the tension in the string at this point. [Ans. 16.15 N]
3. A stone is tied to a weightless string and revolved in a vertical circle of radius 5 m. (i) What should be the minimum speed of the stone at the highest point of the circle so that the string does not slack ?

(ii) What should be speed of the stone at the lowest point in this situation ? Take  $g = 9.8 \text{ ms}^{-2}$ .

[Ans. (i)  $7 \text{ ms}^{-1}$  (ii)  $7\sqrt{5} \text{ ms}^{-1}$ ]

4. The railway bridge over a canal is in the form of an arc of a circle of radius 20 m. What is the minimum speed with which a car can cross the bridge without leaving contact with the ground at the highest point ? Take  $g = 9.8 \text{ ms}^{-2}$ . [Ans.  $14 \text{ ms}^{-1}$ ]
5. An aeroplane describes a vertical circle when looping. Find the radius of the greatest possible loop if the velocity of the aeroplane at the lowest point of its path is  $50 \text{ ms}^{-1}$ . Take  $g = 10 \text{ ms}^{-2}$ . [Ans. 50 m]
6. A weightless thread can bear tension upto 3.7 kg wt. A stone of mass 500 g is tied to it and revolves in a circular path of radius 4 m in vertical plane. If  $g = 10 \text{ ms}^{-2}$ , then what will be the maximum angular velocity of the stone ? [Ans.  $4 \text{ rad s}^{-1}$ ]

**HINTS**

1. Here  $m = 0.5 \text{ kg}$ ,  $u = 10 \text{ ms}^{-1}$ ,  
 $r = 0.8 \text{ m}$ ,  $g = 9.8 \text{ ms}^{-2}$   
 (i)  $T_H = \frac{m}{r} (u^2 - 5gr) = \frac{0.5}{0.8} (10^2 - 5 \times 9.8 \times 0.8)$   
 $= 3.8 \text{ N.}$   
 (ii)  $T_L = \frac{m}{r} (u^2 + gr) = \frac{0.5}{0.8} (10^2 + 9.8 \times 0.8)$   
 $= 67.4 \text{ N.}$

2. From Fig. 5.107,

$$T - mg = \frac{mv^2}{r}$$

or 
$$T = m \left( \frac{v^2}{r} + g \right)$$

$$= 0.5 \times \left[ \frac{3^2}{0.40} + 9.8 \right]$$

$$= 16.15 \text{ N.}$$

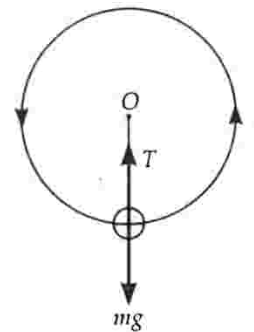

Fig. 5.107

6. Here  $T_{\text{max}} = 3.7 \text{ kg wt} = 3.7 \times 10 = 37 \text{ N}$ ,  
 $m = 500 \text{ g} = 0.5 \text{ kg}$ ,  $r = 4 \text{ m}$   
 As  $T_{\text{max}} = \frac{mv^2}{r} + mg$   
 $\therefore \frac{mv^2}{r} = T_{\text{max}} - mg = 37 - 0.5 \times 10 = 32$   
 or  $v^2 = \frac{32 \times r}{m} = \frac{32 \times 4}{0.5} = 256$  or  $v = 16 \text{ ms}^{-1}$   
 Hence  $\omega = \frac{v}{r} = \frac{16}{4} = 4 \text{ rads}^{-1}$ .

### 5.38 INERTIAL AND NON-INERTIAL FRAMES OF REFERENCE \*

71. What are inertial frames of reference? Give their important features and examples.

**Inertial frame of reference.** A frame of reference in which Newton's first law of motion holds good is called an inertial frame of reference. In such a frame if no force acts on a body, it continues to be at rest or in uniform motion. So it is called an inertial frame. A frame of reference moving with a constant velocity with respect to an inertial frame of reference is also an inertial frame. Acceleration of particles in inertial frames is caused by real forces only.

The important features of inertial frames are as follows :

- (i) All the fundamental laws of physics have been formulated in respect of inertial frame of reference.
- (ii) All the fundamental laws of physics can be expressed so as to have the same mathematical form in all inertial frames of reference.

- (iii) The mechanical and optical experiments performed in an inertial frame in any direction will always yield the same results.

**Examples :** (i) A frame of reference at rest w.r.t. fixed star is an inertial frame of reference.

(ii) Earth can be approximately taken as an inertial frame for measurements taken on its surface.

72. What are non-inertial frames of reference? Give examples. What are fictitious or pseudo forces?

**Non-inertial frame of reference.** A frame of reference which is accelerating with respect to an inertial frame of reference is called non-inertial frame of reference. Newton's laws cannot be applied to the non-inertial frames of reference.

For example, a bus moving along a circular track is an example of accelerated or non-inertial frame of reference. In such a frame, a body experiences an acceleration even if no external force acts on it. When the moving bus turns round a curve, the passengers are thrown away from the centre. This is due to centrifugal force. Such a force which does not really act on particles but appears due to acceleration of the frame is called a fictitious or pseudo force.

### Very Short Answer Conceptual Problems

**Problem 1.** Why do bodies of small mass require small initial effort to bring them into motion?

**Solution.** The inertia of a body is proportional to its mass. Smaller the mass, lesser is the opposition to the change of state of motion.

**Problem 2.** Can a body in linear motion be in equilibrium?

**Solution.** Yes, provided the vector sum of the forces acting upon the body is zero.

**Problem 3.** A body is acted upon by a number of external forces. Can it remain at rest? [Himachal 05]

**Solution.** If the vector sum of all the external forces is zero, then the body will remain at rest.

**Problem 4.** If the net force acting on the body be zero, will the body remain necessarily in rest position? Explain your answer. [Himachal 06]

**Solution.** No, the body may be in the state of uniform motion along a straight line even when the net force acting on the body is zero.

**Problem 5.** If a force is acting on a moving body perpendicular to the direction of motion, then what will be its effect on the speed and direction of the body?

**Solution.** There will be no change in the speed of the body but the direction will change continuously.

**Problem 6.** Why do the passengers fall in backward direction when a bus suddenly starts moving from the rest position? [Delhi 96; Himachal 07C]

**Solution.** When the bus suddenly starts moving, the lower part of the passenger's body begins to move along with the bus while the upper part tend to remain at rest due to inertia of rest. That is why a passenger standing or sitting loosely in a bus falls backward when the bus suddenly starts moving.

**Problem 7.** Why are passengers thrown forward from their seats when a speeding bus stops suddenly?

[Himachal 09; Delhi 09]

**Solution.** This is due to inertia of motion. When the speeding bus stops suddenly, lower part of the body in contact with the seat stops. The upper part of the body of the passengers tends to maintain its uniform motion. Hence the passengers are thrown forward.

**Problem 8.** A man jumping out of a moving train falls with his head forward. Why?

**Solution.** As the man jumps out from a moving train, his feet suddenly come to rest on touching the ground while the upper part of his body continues to move forward. That is why he falls with his head forward. In order to save himself, he should run through some distance in the forward direction.

**Problem 9.** Why do the blades of an electric fan continue to rotate for some time after the current is switched off?

**Solution.** This is due to inertia of motion that the blades of an electric fan continue to rotate for some time even after the fan has been switched off.

**Problem 10.** A stone when thrown on a glass window smashes the windowpane to pieces, but a bullet from the gun passes through making a clean hole. Why?

**Solution.** Due to its small speed, the stone remains in contact with the windowpane for a longer duration. It transfers its motion to the pane and breaks it into pieces. But the particles of windowpane near the hole are unable to share the fast motion of the bullet and so remain undisturbed.

**Problem 11.** We beat a blanket with stick to remove dust particles. Why? [Himachal 04, 07, 09]

**Solution.** When we beat blanket with a stick, it comes into motion. But the dust particles continue to be at rest due to inertia and get detached from the blanket.

**Problem 12.** If you jerk a piece of a paper placed under a book very quickly, the book will not move. Why?

**Solution.** The book continues in its state of rest due to inertia.

**Problem 13.** Why fruits fall down from a tree, when its branches are shaken?

**Solution.** Before shaking the branches, fruits are at rest. When branches are shaken, they come in motion while the fruits tend to remain at rest due to inertia of rest. As a result fruits get detached from the branches and fall down.

**Problem 14.** Why an athlete runs some steps before taking a jump? [Himachal 09]

**Solution.** An athlete always runs for some distance before taking a jump so that inertia of motion may help him in his muscular efforts to take a longer jump.

**Problem 15.** A passenger sitting in a carriage at rest pushes it from within. Will the carriage move?

**Solution.** No, internal forces cannot produce motion in a system.

**Problem 16.** If a ball is thrown up in a moving train, it comes back to the person's hands. Why?

**Solution.** Both during its upward and downward motion, the ball continues to move (inertia of motion) with the same horizontal velocity as the train. In this period, the ball covers the same horizontal distance as the train and so it comes back to the thrower's hands.

**Problem 17.** Why are the passengers thrown outwards when a car in which they are travelling suddenly takes a circular turn? [Himachal 06]

**Solution.** This is because the passengers tend to maintain their direction of motion (inertia of direction) while the direction of car changes when it takes the turn.

**Problem 18.** Why are the wheels of vehicles are provided with mudguards? [Himachal 05C, 06]

**Solution.** When the wheel rotates at a high speed, the mud sticking to the wheel flies off tangentially, this is due to inertia of direction. In order that the flying mud does not spoil the clothes of passersby, the wheels are provided with mudguards.

**Problem 19.** An astronaut accidentally gets thrown out of his small spaceship accelerating in inter-stellar space at a constant rate of  $100 \text{ ms}^{-2}$ . What is the acceleration of the astronaut the instant after he is outside the spaceship? [NCERT]

**Solution.** Assuming that there are no nearby stars to exert gravitational force and the small spaceship exerts negligible gravitational force on the astronaut, then moment he gets out of the ship, there is no external force on him. By the first law of motion, the acceleration of the astronaut is zero.

**Problem 20.** Why is Newton's first law of motion also called law of inertia?

**Solution.** According to Newton's first law of motion, a body by itself cannot change its state of rest or of uniform in a straight line. This inability of a body is called inertia. That is why Newton's first law of motion is also called law of inertia.

**Problem 21.** A thief jumps from the upper storey of a house with a load on his back. What is the force of the load on his back when the thief is in air?

**Solution.** Zero. This is because a condition of weightlessness exists during a free fall.

$$W = m(g - a) = m(g - g) = 0.$$

**Problem 22.** A soda-water bottle is falling freely. Will the bubbles of the gas rise in the water of the bottle?

**Solution.** Bubbles will not rise in water. The water in the freely-falling bottle is in the state of weightlessness. Consequently, the pressure in water does not increase with depth. No upthrust acts on the bubbles and they do not rise.

**Problem 23.** A bird is sitting on the floor of a wire cage and the cage is in the hand of a boy. The bird starts flying in the cage. Will the boy experience any change in the weight of the cage?

**Solution.** The air inside the wire cage is in free contact with the atmospheric air. When the bird starts flying inside the cage, the weight of the bird is no more experienced and the cage will appear lighter than before.

**Problem 24.** The distance travelled by a body is directly proportional to time. Is any external force acting on it?

**Solution.** As  $s \propto t$  or  $s = kt$

$$\therefore v = \frac{ds}{dt} = k, \quad a = \frac{dv}{dt} = 0$$

i.e., the body is moving with a uniform velocity and no external force is acting on it.

**Problem 25.** Chinawares are wrapped in straw paper before packing. Why?

**Solution.** The straw paper between the chinaware increases the time of experiencing the jerk during transportation. Hence, they strike against each other with less force and are less likely to be damaged.

**Problem 26. Why we are hurt less when we jump on a muddy floor in comparison to a hard floor ?**

**Solution.** When we jump on a muddy floor, the floor is carried in the direction of the jump and the time interval  $\Delta t$  for which force acts is increased. This decreases rate of change of momentum and hence the force of reaction. Therefore we are hurt less.

**Problem 27. Why are shockers used in cars, scooters and motorcycles ?**

**Solution.** In the event of jerk or jump, the time for which the force acts increases. Since the product of force and time is to remain constant in a given situation, therefore the force decreases.

**Problem 28. Why buffers are provided between the bogies of a railway train ?**

**Solution.** Due to buffer spring, the time of impact between the bogies increases, and the force acting between the bogies ( $F = \text{Impulse} / \text{time}$ ) decreases. Consequently, passengers sitting inside the bogies do not experience strong jerks. For the same reason shockers are provided in all vehicles.

**Problem 29. Why is it necessary to bend knees while jumping from greater height ?**

**Solution.** During the jump, our feet at once come to rest and for this smaller time ( $F = \text{Impulse} / \text{time}$ ) a large force acts on feet. If we bend the knees slowly, the value of time of impact increases and less force acts on our feet. So we get less hurt.

**Problem 30. A brick can be pushed gently on the smooth floor by applying force with our foot. But if we kick the brick, the foot is hurt. Why ?**

**Solution.** When the brick is kicked, the time for which force is impressed is short and hence rate of change of momentum of the brick is large. The brick in turn, due to reaction applies large force on the foot. This force may hurt our foot.

**Problem 31. Why is it that when a man jumps down from a height of several storeys into a stretched trapaulin, he receives no injury ?**

**Solution.** When the man jumps, the trapaulin gets depressed at the place of impact. This increases the time of impact ( $\Delta t$ ). As a result, the trapaulin exerts a very small force ( $F = \text{impulse}/\text{time}$ ) on the man, and he receives no injury.

**Problem 32. According to Newton's third law, every force is accompanied by equal and opposite force. How can anything move then ?**

**Solution.** Though action and reaction act simultaneously, but they act on different bodies. This makes the motion possible.

**Problem 33. Why is it difficult to drive a nail into a wooden block without supporting it ?**

**Solution.** When we hit the nail with a hammer, the nail and unsupported block together move forward as a

single system. There is no force of reaction. When the block is rested against a support, the reaction of the support holds the block in position and the nail is driven into the block.

**Problem 34. Why it is difficult to climb up a greasy pole ?**

**Solution.** When a person climbs up a pole, he presses the pole downward with his feet and the pole, in turn, pushes the person upwards with an equal force. If the pole is greasy, its surface becomes slippery and the person is not able to press it. As there is no action, there will be no reaction. Hence it becomes difficult for the person to climb up.

**Problem 35. In a tug of war, the team that pushes harder against the ground wins. Why ?**

**Solution.** The team that pushes harder against ground gets greater reactional force and this leads them to win.

**Problem 36. Can a sailboat be propelled by air blown at the sails from a fan attached to the boat ?**

**Solution.** No. When the fan pushes the sail by blowing air, the air also pushes the fan in the opposite direction. As the fan is also a part of the boat, the vector sum of the momenta of the fan and the boat is zero. The boat will move only if some external agency applies force on it.

**Problem 37. A man is at rest in the middle of a pond on perfectly frictionless ice. How can he get himself to the shore ?**

**Solution.** If the man throws away his shirt in a direction opposite to the desired direction of motion, he can get himself to the shore.

**Problem 38. Two bodies of masses  $M$  and  $m$  are allowed to fall from the same height. If the air-resistance be same for each body, will the two bodies reach the earth simultaneously ?**

**Solution.** No. Let the air-resistance on each body be  $F$ .  
Net downward force on body of mass  $M = Mg - F$

Acceleration of body of mass  $M$ ,  $a = \frac{Mg - F}{M} = g - \frac{F}{M}$

Similarly acceleration of body of mass  $m$ ,  $a' = g - \frac{F}{m}$

As  $M > m \therefore a > a'$

Thus the acceleration of the larger mass is greater, it will reach the earth earlier.

**Problem 39. There is some water in a beaker placed on the pan of a spring balance. If we dip our finger in this water without touching the bottom of the beaker, then what would be the effect on the reading of the balance ?**

**Solution.** The reading will increase. The water will exert upthrust on the finger and the finger will exert an equal force of reaction on water in the downward direction *i.e.*, on the bottom of the beaker.

**Problem 40. Two boys having the same mass are standing on ice-skates at some distance apart on a frictionless surface. A rope is fastened around the body of a boy,**



the other end of which is in the hand of the second boy. What would happen if the second boy pulls the rope ?

**Solution.** The two boys will move towards each other with the same velocity so that their combined momentum is still zero (conservation of momentum).

**Problem 41. A retarding force is applied to stop a motor car. If the speed of the motor car is doubled, how much more distance will it cover before stopping under the same retarding force ?**

**Solution.** Work done against retarding force  
= Loss in K.E.

$$\text{In first case, } F \times s = \frac{1}{2} mv^2 \quad \dots(i)$$

$$\text{In second case, } F \times s' = \frac{1}{2} m(2v)^2 \quad \dots(ii)$$

$$\text{From (i) and (ii), } s' = 4s$$

Thus the motor car will cover a distance four times longer than before.

**Problem 42. Why does a rifle give a backward kick on firing a bullet ?**

**Solution.** Before firing, both the bullet and the rifle are at rest and their total momentum is zero. After firing, the bullet gains a large momentum in the forward direction. To conserve momentum, the rifle gains an equal momentum in the opposite direction. So the rifle gives a backward kick.

**Problem 43. Why is it advisable to hold a gun tight to one's shoulder when it is being fired ?** [Himachal 08]

**Solution.** The recoiling gun can hurt the shoulder. If the gun is held tightly against the shoulder, the body and the gun will constitute one system. Total mass becomes large and the recoil velocity becomes small.

**Problem 44. When a body falls to the earth, the earth also moves up to meet it. But the earth's motion is not noticeable. Why ?**

**Solution.** We know that acceleration is the ratio of applied force and mass of the body. Since the earth is a massive body, therefore its acceleration is very small. Hence the motion of the earth is not noticeable.

**Problem 45. A meteorite burns in the atmosphere before it reaches the earth's surface. What happens to its momentum ?**

**Solution.** Since the meteorite moves under the force of gravity, therefore its momentum changes but remains conserved before and after burning.

**Problem 46. Why does a heavy rifle not kick as strongly as a light rifle using the same cartridge ?**

**Solution.** Recoil velocity of a rifle,

$$\vec{V} = -\frac{m}{M} \vec{v} \quad \text{i.e., } \vec{V} \propto \frac{1}{M}$$

Thus the recoil velocity of the heavy rifle is smaller than that of the light rifle, so it does not kick strongly.

**Problem 47. Why is static friction called a self-adjusting force ?**

**Solution.** As the applied force increases, the static friction also increases and becomes equal to the applied force. That is why static friction is called a self-adjusting force.

**Problem 48. Can we get off a frictionless horizontal surface by jumping ?**

**Solution.** No, because a frictionless surface is unable to provide reaction which is necessary for jumping.

**Problem 49. Automobile tyres are generally provided with irregular projections over their surfaces. Why ?**

**Solution.** Irregular projections increase the friction between the rubber tyres and the road. This provides a firm grip between the tyres and the road and prevents slipping.

**Problem 50. Carts with rubber tyres are easier to fly than those with iron wheels. Why ?**

**Solution.** The coefficient of friction between rubber tyres and road is much smaller than that between iron wheels and the road.

**Problem 51. Sand is thrown on tracks covered with snow. Why ?** [Himachal 09]

**Solution.** When tracks are covered with snow, there is considerable reduction of frictional force. So, the driving is not safe. When sand is thrown on the snow-covered tracks, the frictional force increases. So, safe driving is possible.

**Problem 52. Why are wheels of automobiles made circular ?**

**Solution.** Circular wheels roll on the road and rolling friction comes into play during the motion of automobile. Rolling friction is less than the sliding friction. It is due to this reason that wheels of automobiles are made circular.

**Problem 53. Proper inflation of tyres of vehicles saves fuel. Why ?**

**Solution.** When the tyre is properly inflated, the area of contact between the tyre and the ground is reduced. This reduces rolling friction. Consequently, the automobile covers greater distance for the same quantity of fuel consumed.

**Problem 54. It is difficult to move a cycle along a road with its brakes on. Explain ?** [Himachal 07C]

**Solution.** When the cycle is moved with brakes on, the wheels can only skid. So, the friction is sliding in nature. Since the sliding friction is greater than rolling friction, therefore, it is difficult to move a cycle with its brakes on.

**Problem 55. A large size brake on bicycle is as effective as small one. Comment.**

**Solution.** Action of brakes is based upon friction. But the friction is independent of the area of surfaces in contact so long as the normal reaction remains the same. Hence, large size brakes and normal size brakes will be equally effective if the material of brakes remains unchanged.

**Problem 56. Why is it difficult to put a cycle into motion than to maintain its motion ?** [Chandigarh 02]

**Solution.** To put a cycle into motion, one needs to overcome limiting friction while to maintain its motion,

one needs to overcome kinetic friction. Limiting friction is greater than the kinetic friction. So it is difficult to put a cycle into motion than to maintain its motion.

**Problem 57. How does friction help us in walking ?**

**Solution.** Due to friction, we are able to push the ground backward during walking. The reaction of the ground helps us to move forward.

**Problem 58. Why do we slip on a rainy day ?**

[Himachal 05C, 06 ; Delhi 10]

**Solution.** On a rainy day, the wet ground becomes very smooth. The friction between our feet and the ground is greatly reduced. It causes us to slip.

**Problem 59. Why is it difficult to walk on sand ?**

**Solution.** Because of its yielding nature, sand cannot exert as much forward thrust as hard ground does.

**Problem 60. Why frictional force gets increased when a surface is polished beyond a certain limit ?**

**Solution.** When surfaces are highly polished, the area of contact between them increases. As a result of this, a large number of atoms and molecules lying on both the surfaces start exerting strong attractive forces on each other and therefore frictional force increases.

**Problem 61. When a person walks on a rough surface, the frictional force exerted by the surface on the person is opposite to direction of his motion. State whether it true or false ?**

**Solution.** False. When a person walks, he pushes the ground backward with his foot. The tendency of the foot when it is in the contact of the earth is to move backward. Hence the force of friction acts in the forward direction, *i.e.*, in a direction in which the man walks.

**Problem 62. Why has a horse to pull a cart harder during the first few steps of his motion ?**

Or

**A horse has to apply more force to start a cart than to keep it moving. Why ?** [Himachal 07C ; Delhi 09]

**Solution.** During the first few steps of his motion, the horse has to work against the limiting friction and once the cart starts moving, the horse has to work against kinetic friction which is less than limiting friction.

**Problem 63. Is it unreasonable to expect the coefficient of friction to exceed unity ?**

**Solution.** No. The coefficient is less than unity for normal plane surfaces. But when the surfaces are so irregular that they have sharp minute projections and cavities on them, then the coefficient of friction may exceed unity.

**Problem 64. Is friction a non-conservative force ?**

**Solution.** Yes. When the direction of motion of a body reverses, the direction of friction is also reversed. Work has to be done against friction both during forward and return journey *i.e.*, work done against friction along a closed path is not zero. So friction is a non-conservative force.

**Problem 65. For uniform circular motion, does the direction of centripetal force depend on the sense of rotation ?**

**Solution.** No. Whether a body revolves clockwise or anticlockwise, the centripetal force always acts along the radius towards the centre of the circle.

**Problem 66. A stone tied at the end of a string is whirled in a circle. When the string breaks, the stone flies away tangentially ? Explain why. [Meghalaya 1998]**

**Solution.** The instantaneous velocity of the stone moving round the circle is along the tangent to the circular path. When the string breaks, the centripetal force vanishes. Due to the inertia of motion, the stone flies away tangentially.

**Problem 67. Why does a child in a merry-go-round press the side of his seat radially outward ?**

**Solution.** In accordance with Newton's third law, the seat will press the child inward, providing the necessary centripetal force.

**Problem 68. Why does skidding takes place generally on a rainy day along a curved path ?**

**Solution.** The force of friction between the road and the tyres of the vehicle may not be sufficient to provide the necessary centripetal force.

**Problem 69. A car is taking a sudden turn to the left. A passenger in the front seat finds himself sliding towards the door. Explain, indicating the forces acting on the passenger and the car at this instant.**

**Solution.** The passenger in the front seat slides towards the door *i.e.*, away from the circular turn. This is because of the centrifugal force acting on the passenger.

**Problem 70. The outer rail of a curved railway track is generally raised over the inner. Why ?**

**Solution.** When the outer rail of a curved railway track is raised over the inner, the horizontal component of the normal reaction of the rails provides the necessary centripetal force for the train to enable it move along the curved path.

**Problem 71. A motor cyclist is going in a vertical circle. What is the necessary condition so that he may not fall down ?**

**Solution.** The necessary condition that the motor cyclist may not fall down is  $mv^2/r \geq mg$  *i.e.*,  $v \geq \sqrt{rg}$  at the highest point and  $v \geq \sqrt{5gr}$  at the lowest point.

**Problem 72. A bucket containing water is rotated in a vertical circle. Explain, why the water does not fall.**

**Solution.** For its revolution in a vertical circle, water in the bucket needs a centripetal force. The weight of the water due to which water can fall is used up in providing the necessary centripetal force and the water does not fall.

**Problem 73. Why does a pilot looping a vertical loop not fall down even at the highest point ?**

**Solution.** At the highest point of the vertical loop, the weight of the pilot due to which he can fall is used up in providing him the necessary centripetal force.

**Problem 74.** What is the maximum possible velocity at the lowest position for oscillation of a simple pendulum of length  $L$ . What can happen to the motion if the velocity exceeds this value ?

**Solution.** The maximum possible velocity at the lowest point for oscillation of simple pendulum  $= \sqrt{3gL}$ . When velocity exceeds  $\sqrt{3gL}$  but is less than  $\sqrt{5gL}$ , the bob leaves the vertical circle. When  $v = \sqrt{5gL}$ , the bob completes the vertical circle.

**Problem 75.** A cricket player lowers his hands to catch the ball safely. Explain, why ?

[Himachal 04, 05C, 07C, 09, 09C]

**Solution.** The impulse is equal to the product of the force exerted by the ball and the time of catch. By lowering the hands, the time of catch increases. Then the force exerted on the hands becomes much smaller and it does not hurt the cricketer.

**Problem 76.** It is easy to catch a table tennis ball than a cricket ball even both are moving with same velocity. Why ?

[Himachal 09 ; Central Schools 05]

**Solution.** Due to its small mass, the momentum of the table tennis ball is much smaller than that of the cricket ball of same velocity. Less force is required to stop the table tennis ball than the cricket ball. Hence it is easy to catch the table tennis ball than the cricket ball.

**Problem 77.** Why does a cyclist bend inwards while riding along a curved road ?

[C.S. 05 ; Himachal 07C]

**Solution.** A cyclist bends inwards because then the horizontal component of the normal reaction of the ground provides the necessary centripetal force for going along the curved road.

**Problem 78.** The motion of a particle of mass  $m$  is described by  $y = ut + 1/2 gt^2$ . Find the force acting on the particle.

[NCERT]

**Solution.** We have  $y = ut + 1/2 gt^2$

Velocity,  $v = \frac{dy}{dt} = u + gt$

Acceleration,  $a = \frac{dv}{dt} = g$

Force,  $F = ma = mg$

Thus the given equation describes the motion of a particle under acceleration due to gravity and  $y$  is the position coordinate in the direction of  $g$ .

**Problem 79.** A particle of mass 0.3 kg is subjected to a force of  $F = -kx$  with  $k = 15 \text{ Nm}^{-1}$ . What will be its

initial acceleration, if it is released from a point 20 cm away from the origin ?

[AIEEE 05]

**Solution.** Here

$$k = 15 \text{ Nm}^{-1}, x = 20 \text{ cm} = 0.20 \text{ m}, m = 0.3 \text{ kg}$$

$$F = -kx = 15 \times 0.20 = -3 \text{ N}$$

Acceleration,  $a = \frac{F}{m} = \frac{-3}{0.3} = -10 \text{ ms}^{-2}$ .

**Problem 80.** A block of mass  $M$  is pulled along a horizontal frictionless surface by a rope of mass  $m$ . A force  $P$  is applied at the free end of the rope. Find the force exerted by the rope on the block.

[AIEEE 03]

**Solution.** If  $a$  is the acceleration produced, then

$$P = (M + m)a \quad \text{or} \quad a = \frac{P}{M + m}$$

Force exerted by the rope on the block

$$F = Ma = \frac{MP}{M + m}$$

**Problem 81.** Three forces  $F_1, F_2$  and  $F_3$  are acting on a particle of mass  $m$ , such that  $F_2$  and  $F_3$  are mutually perpendicular and under their effect, the particle remains stationary. What will be the acceleration of the particle, if the force  $F_1$  is removed ?

[AIEEE 02]

**Solution.** As the particle remains stationary under the action of the three forces, so  $\vec{F}_1 + \vec{F}_2 + \vec{F}_3 = 0$

When force  $\vec{F}_1$  is removed, the net force left is

$$\vec{F}_2 + \vec{F}_3 = -\vec{F}_1$$

Acceleration,  $a = -\frac{\vec{F}_1}{m}$ .

**Problem 82.** A spring balance is attached to the ceiling of a lift. A man hangs his bag on the spring and the spring reads 49 N, when the lift is stationary. What will be the reading of the spring balance, if the lift moves downward with an acceleration of  $5 \text{ ms}^{-2}$ .

[AIEEE 03]

**Solution.** When the lift is stationary. The reaction of the spring is equal to weight of the bag.

$$\therefore R = mg = 49 \text{ N} \quad \text{or} \quad m = \frac{49}{g} = \frac{49}{9.8} = 5 \text{ kg}$$

When the lift moves downward. The reaction is

$$R' = m(g - a) = 5(9.8 - 5) = 24 \text{ N}.$$

## Short Answer Conceptual Problems

**Problem 1.** Why does Newton's first law of motion appear to be contradicted in our day-to-day life ?

**Solution.** In our day-to-day observations, we find that when we push a block lying on the surface of a table, it covers some distance before it stops. At first sight, it

seems to contradict Newton's first law of motion. However, the motion of the block is being opposed by the force of friction between the block and the table and also by air resistance. In the absence of such opposing forces, the block would continue to move on its own.

**Problem 2. Explain, why**

- (a) The passengers are thrown forward from their seats, when a speeding bus stops suddenly.
- (b) Does a cricketer move his hand backwards while holding a catch ?
- (c) Is the boat pushed away when a man jumps out of the boat ? [Delhi 08]

**Solution.** (a) Refer to the solution of Problem 7 on page 5.62.

(b) Refer to the answer of NCERT Exercise 5.23(d) on page 5.80.

(c) Initially, the total momentum of the boat and the man is zero. As the man jumps out of the boat, he gains momentum in the forward direction. To conserve momentum, the boat also gains an equal and opposite momentum. So the boat moves away from the shore.

**Problem 3. Explain :** (a) Why are ball bearings used in machinery ? (b) Why does a horse have to apply more force to start a cart than to keep it moving ? (c) What is the need for banking the tracks ? [Delhi 09]

**Solution.** (a) By using ball bearings between the moving parts of a machinery, the sliding friction gets converted into rolling friction. The rolling friction is much smaller than sliding friction. This reduces power dissipation.

(b) Refer to the solution of Problem 62 on page 5.66.

(c) When the circular track is banked, the horizontal component of the normal reaction of the road provides the necessary centripetal force for the vehicle to move it along the curved path. This reduces wear and tear of the tyres.

**Problem 4. The speed of driving a car safely depends upon the range of headlight. Explain.**

**Solution.** By the range of the headlight of a car, we mean the maximum distance(s) upto which an obstacle on the road can be seen by the driver in the darkness. The driver has to stop the car before it reaches the obstacle. The retarding force acting on the car is constant. If, on applying brakes, the retardation in the car is  $a$ , then to stop the car within distance  $s$ , the speed  $v$  of the car should be less than  $\sqrt{2as}$ . Thus the speed of the car depends on the range ( $s$ ) of the headlight.

**Problem 5. A bird is sitting on the floor of a closed glass cage and the cage is in the hand of a girl. Will the girl experience any change in the weight of the cage when the bird (i) starts flying in the cage with a constant velocity (ii) flies upwards with acceleration (iii) flies downwards with acceleration ?**

**Solution.** In a closed cage, the inside air is bound with the cage.

- (i) As the acceleration is zero, there is no change in the weight of the cage.
- (ii) In this case, the reaction  $R$  is given by

$$R - Mg = Ma \quad \text{or} \quad R = M(g + a)$$

Thus the cage will appear heavier than before.

- (iii) In this case, the reaction  $R$  is given by

$$Mg - R = Ma \quad \text{or} \quad R = M(g - a)$$

Thus the cage will appear lighter than before.

**Problem 6. A man stands in a lift going downward with uniform velocity. He experiences a loss of weight at the start but not when lift is in uniform motion. Explain why ?**

**Solution.** The apparent weight is given by

$$R = W - ma = mg - ma \quad \text{or} \quad R = m(g - a)$$

Since lift is in acceleration in the start,  $a \neq 0$ , so  $R < mg$ . When lift comes in uniform motion, acceleration ceases ( $a = 0$ ) and man experiences his own weight.

**Problem 7. Aeroplanes having wings fly at low altitudes while jet planes fly at high altitudes. Why ?**

**Solution.** The wings of the aeroplane push the external air backward and the aeroplane moves forward by the reaction of the pushed air. At lower altitude the air is dense and so the aeroplane receives sufficient reactional force to move forward. In the jet plane the external air is sucked into the plane and compressed. Hence for the air to be dense is not only unnecessary but also undesirable. The reason is that jet planes fly with very large velocity. If air is dense, then due to the air-friction the plane will become very hot. Therefore, jet planes fly at high altitude where air-density is very small.

**Problem 8. A person (mass  $m$ ) is hanging from a rope fastened to a stationary balloon (mass  $M$ ). If the person climbs along the rope, then with what velocity the balloon will move and in what direction ? The velocity of the person relative to the rope is  $v$ .**

**Solution.** The initial momentum of the person and balloon is zero. Hence when the person climbs, the balloon will come down with such a velocity  $u$  that the total momentum be still zero. The velocity of the person relative to earth is  $(v - u)$ . Hence

$$m(v - u) - Mu = 0 \quad \text{or} \quad u = \frac{mv}{M + m}$$

**Problem 9. A rope is hanging from a tree, as shown in Fig. 5.108. Bananas are fastened to the higher end of the rope, and a monkey is hanging along the rope near its lower end. The monkey climbs along the rope, will it be able to eat the bananas ?**

**Solution.** No. As the monkey climbs up, the bananas also move up through equal distance so that the momentum is conserved. Here the branch of the tree acts as a pulley which reverses the direction of momentum. When the monkey and the bananas both move up with the same velocity, the combined momentum remains zero.

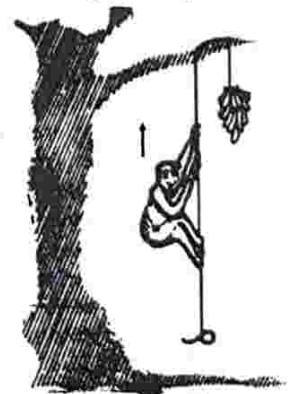

**Fig. 5.108**

**Problem 10.** A long rope is hanging, passing over a pulley. Two monkeys of equal weights climb up from the opposite ends of the rope. One of them climbs up more rapidly relative to rope. Which monkey will reach first at the top? The pulley is frictionless and the rope is massless and inextensible.

**Solution.** There is no external force which may provide momentum to any monkey. The monkeys themselves give equal momenta to each other (through the rope). Therefore, two monkeys will climb up the rope at the same rate relative to the earth. As their masses are equal, they will reach the top simultaneously.

**Problem 11.** When a ball is thrown upward, its momentum first increases and then decreases. Is the conservation of momentum violated in this process?

**Solution.** No. The combined momentum of the ball and the earth is conserved. The ball attracts the earth by the same force as the earth attracts the ball. When the ball moves upward, its momentum decreases in the upward direction but simultaneously the momentum of the earth increases in the upward direction at the same rate. Similarly, when the ball falls down, its momentum increases in the downward direction but simultaneously the momentum of the earth increases in the upward direction at the same rate.

**Problem 12.** A disc of mass  $m$  is placed on a table. A stiff spring is attached to it and is vertical. To the other end of the spring is attached a disc of negligible mass. What minimum force should be applied to the upper disc to press the spring such that the lower disc is lifted off the table when the external force is suddenly removed?

**Solution.** The minimum applied force should be  $mg$ . When a force  $mg$  is applied vertically downwards on the upper disc, the lower disc gets pressed against the floor with a force equal to  $mg$ . The floor exerts an upward reaction equal to  $mg$ . When the external force is suddenly removed, this force of reaction lifts up the lower disc.

**Problem 13.** Can a single isolated force exist in nature? Give reason.

**Solution.** No. According to Newton's third law of motion, to every action there is always an equal and opposite reaction. So the forces always exist in pairs. When we talk of a single force, we are just considering only one aspect of the mutual interaction.

**Problem 14.** A body is dropped from the ceiling of a transparent cabin falling freely towards the earth. Describe the motion of the body as observed by an observer (i) sitting in the cabin (ii) standing on the earth.

**Solution.** (i) The body will appear stationary in air.

(ii) The body will appear falling freely under gravity.

**Problem 15.** A ball is suspended by a cord from the ceiling of a motor car. What will be the effect on the

position of the ball if (i) the car is moving with uniform velocity (ii) the car is moving with accelerated motion and (iii) the car is turning towards right?

**Solution.**

(i) The ball will remain suspended vertically.

(ii) The ball will move in backward direction.

(iii) The ball will move towards left.

**Problem 16.** A block of mass  $M$  is supported by a cord  $C$  from a rigid support, and another cord  $D$  is attached to the bottom of the block. If you give a sudden jerk to  $D$ , it will break. But if you pull on  $D$  steadily, chord  $C$  will break. Why?

**Solution.** When a sudden jerk is given to  $D$ , the upper portion of the system is not able to share the force in short time and the block tends to remain at rest (inertia of rest). So the chord  $D$  breaks.

When the chord  $D$  is pulled steadily, the force gets sufficient time to reach the chord  $C$  which ultimately breaks.

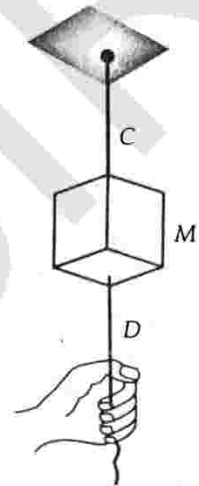

Fig. 5.109

**Problem 17.** A vessel containing water is given a constant acceleration  $a$  towards the right, along a horizontal path. Which of the following figures correctly represents the surface of the liquid?

**Solution.** Fig. 5.110(c) is correct. This is because the liquid experiences a backward force.

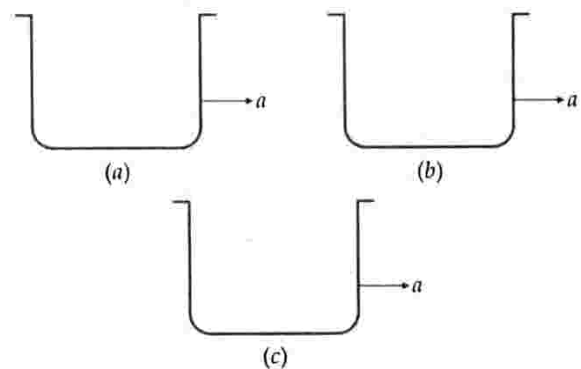

Fig. 5.110

**Problem 18.** When brakes are applied in a bicycle, the brake shoes apply frictional force on the wheels. The forces are internal for the system (bicycle). For retardation, external forces must act on the system. The force of friction at the road surface remains the same before and after the brakes are applied ( $f = \mu R$ ). How does the bicycle stop?

**Solution.** When brakes are applied, the wheels are prevented from rolling. During rolling, the friction at the road surface does not cause retardation. When rolling is prevented, the wheels have to slip on the road. The friction of the road now causes retardation.

**Problem 19.** A light string passing over a smooth pulley connects two blocks of masses  $m_1$  and  $m_2$  (vertically). If the acceleration of the system is  $g/8$ , find the ratio of the two masses. [AIEEE 02]

## HOTS

**Problem 1.** For ordinary terrestrial experiments, which of the observers below are inertial and which non-inertial :

- a child revolving in a "giant wheel",
- a driver in a sports car moving with a constant high speed of 200 km/h on a straight road,
- the pilot of an aeroplane which is taking off,
- a cyclist negotiating a sharp turn,
- the guard of a train which is slowing down to stop at a station ?

**Solution.** (a) The child is *non-inertial observer*, because the revolving giant wheel has an accelerated motion.

(b) The driver is an *inertial observer*, because the sports car is moving with a constant speed in a straight line.

(c) The pilot is *non-inertial observer*, because the aeroplane accelerates while taking off.

(d) The cyclist is *non-inertial observer*, because cycle has an accelerated motion at the sharp turn.

(e) The guard is *non-inertial observer*, because the train is under retardation.

**Problem 2.** One often comes across the following type of statement concerning circular motion : 'A particle moving uniformly along a circle experiences a force directed towards the centre (centripetal force) and an equal and opposite force directed away from the centre (centrifugal force). The two forces together keep the particle in equilibrium'. Explain what is wrong with this statement. [NCERT]

**Solution.** The statement is correct relative to a non-inertial frame rotating with the particle. For example, consider an observer moving with the same acceleration ( $= v^2/r$ ) as that of the particle. For him, the particle remains at rest. The centripetal force equals the centrifugal force. Centrifugal force is not a real force. It arises only because of the non-inertial nature of the observer himself.

The given statement is wrong relative to an inertial frame e.g., the laboratory frame. For an inertial

**Solution.** As  $a = \frac{m_1 - m_2}{m_1 + m_2} g$   $\therefore \frac{g}{8} = \frac{m_1 - m_2}{m_1 + m_2} g$

$$\text{or } \frac{m_1 - m_2}{m_1 + m_2} = \frac{1}{8}$$

$$\text{or } \frac{(m_1 + m_2) + (m_1 - m_2)}{(m_1 + m_2) - (m_1 - m_2)} = \frac{8 + 1}{8 - 1}$$

$$\text{or } \frac{m_1}{m_2} = \frac{9}{7} = 9 : 7.$$

## Problems on Higher Order Thinking Skills

observer (stationary observer), the particle in circular motion is not in equilibrium, it has a centripetal acceleration. There is no force such as centrifugal force.

**Problem 3.** Two particles of masses  $m_1$  and  $m_2$  in projectile motion have velocities  $\vec{v}_1$  and  $\vec{v}_2$  respectively at time  $t = 0$ .

They collide at time  $t_0$ . Their velocities become  $\vec{v}'_1$  and  $\vec{v}'_2$  at time  $2t_0$  while still moving in air. Find the value of  $|(m_1 \vec{v}'_1 + m_2 \vec{v}'_2) - (m_1 \vec{v}_1 + m_2 \vec{v}_2)|$ . [IIT Screening 01]

**Solution.** As there is no external force in the horizontal direction, the momentum is changed in the vertical direction only by the gravitational force in time 0 to  $2t_0$ . Change in momentum = external force  $\times$  time interval

$$\begin{aligned} \therefore |(m_1 \vec{v}'_1 + m_2 \vec{v}'_2) - (m_1 \vec{v}_1 + m_2 \vec{v}_2)| \\ = (m_1 + m_2) g \times (2t_0 - 0) = 2(m_1 + m_2) g t_0. \end{aligned}$$

**Problem 4.** Two bodies A and B, each of mass  $m$ , are connected together by a massless spring. A force  $F$  acts on the mass B as shown in Fig. 5.111. At the instant shown, the body A has an acceleration  $a$ , what is the acceleration of B ? [CPMT 93]

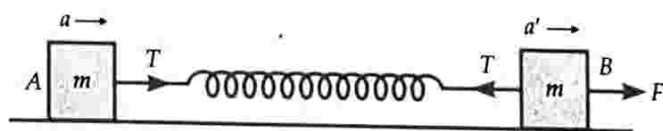

**Fig. 5.111**

**Solution.** Let  $T$  be the tension in the string. Then the equation of motion for A can be written as

$$T = ma$$

Let  $a'$  be the acceleration of B. Then for motion of B,

$$ma' = F - T = F - ma$$

$$\text{or } a' = \frac{F}{m} - a.$$

**Problem 5.** A piece of uniform string hangs vertically so that its free end just touches horizontal surface of a table. If now the upper end of the string is released, show that at any instant during the falling of the string, the total force on the surface is three times the weight of that part of the string lying on the surface. [Roorkee 96]

**Solution.** Let  $m$  be the mass per unit length of the string. Each element of the string falls freely. Initial velocity at the end is zero. When the string has fallen through distance  $y$ , its velocity  $v$  at that instant is given by

$$v^2 - 0^2 = 2gy$$

or  $v = \sqrt{2gy}$

After this instant, the length of the string that falls in small time  $dt$  is

$$dy = v dt$$

Mass of length  $dy$  of the string

$$= m dy = m v dt$$

Momentum transferred to the table in small time  $dt$  is

$$dp = (m v dt) \cdot v = m v^2 dt$$

$\therefore$  Force exerted on the table,

$$F_1 = \frac{dp}{dt} = m v^2 = m(2gy) = (2my)g$$

Since a length  $y$  of the string already lies on the table which also exerts force on the table given by

$$F_2 = \text{weight of length } y = (my)g$$

Total force exerted on the table is

$$F = F_1 + F_2 = (2my)g + (my)g = 3(my)g = 3 \times \text{Weight of the part of the string on the table.}$$

**Problem 6.** An explosion blows a rock into three pieces. Two pieces whose masses are 200 kg and 100 kg go off at right angles to each other with a velocity of  $8 \text{ ms}^{-1}$  and  $12 \text{ ms}^{-1}$  respectively. If third piece flies off with a velocity of  $25 \text{ ms}^{-1}$ , then calculate the mass of this piece and indicate the direction of flight of this piece in a diagram.

**Solution.** As shown in Fig. 5.113, suppose the rock explodes at point O. The 100 kg piece moves along OA and 200 kg piece along OB. The third piece of mass  $m$  moves along OC making an angle  $\theta$  with OA.

Before explosion, momentum of the rock in any direction is zero.

By conservation of momentum along OA,

$$100 \times 12 - m v \cos \theta = 0$$

or  $1200 = m v \cos \theta$

$$\therefore m \cos \theta = \frac{1200}{v} = \frac{1200}{25} = 48 \quad \dots(i)$$

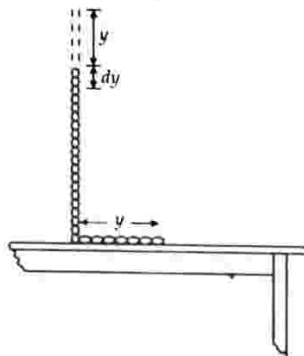

Fig. 5.112

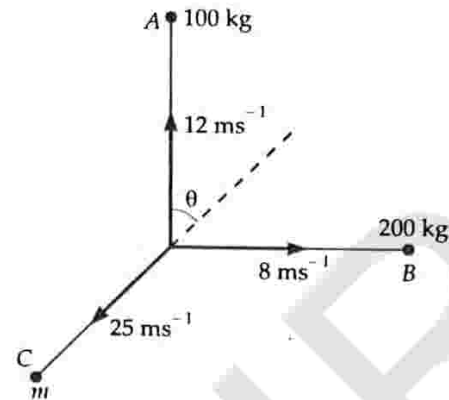

Fig. 5.113

By conservation of momentum along OB,

$$200 \times 8 - m v \sin \theta = 0$$

or  $1600 = m v \sin \theta$

or  $m \sin \theta = \frac{1600}{v} = \frac{1600}{25} = 64 \quad \dots(ii)$

Squaring and adding (i) and (ii), we get

$$m^2 = 48^2 + 64^2 = 6400 \quad \therefore m = 80 \text{ kg}$$

Dividing (ii) by (i), we get,

$$\tan \theta = \frac{64}{48} = \frac{4}{3} \quad \therefore \theta = \tan^{-1} \left( \frac{4}{3} \right) = 53^\circ.$$

**Problem 7.** A block of mass 0.1 kg is held against a wall by applying a horizontal force of 5 N on the block. If the coefficient of friction between the block and the wall is 0.5, what is the magnitude of the frictional force acting on the block? [IIT 94]

**Solution.** In Fig. 5.114, the block presses the wall with a horizontal force,  $F = 5 \text{ N}$ . The wall exerts a force of reaction  $R$  on the block. The weight  $mg$  acts vertically downwards and static friction  $f_s$  acts vertically upward.

In equilibrium,

$$R = 5 \text{ N}$$

and  $f_s = mg$

$$= 0.1 \times 9.8 = 0.98 \text{ N.}$$

Fig. 5.114

**Problem 8.** A body of mass 2 kg is being dragged with a uniform velocity of  $2 \text{ ms}^{-2}$  on a rough horizontal plane. The coefficient of friction between the body and the surface is 0.2. Calculate the amount of heat generated per second. Take  $g = 9.8 \text{ ms}^{-2}$  and  $J = 4.2 \text{ J cal}^{-1}$ . [IIT 80]

**Solution.** Here  $m = 2 \text{ kg}$ ,  $u = 2 \text{ ms}^{-1}$ ,  $\mu = 0.2$

Force of friction,

$$f = \mu R = \mu mg = 0.2 \times 2 \times 9.8 = 3.92 \text{ N}$$

Distance moved per second,  $s = ut = 2 \times 1 = 2 \text{ m}$

Work done per second,  $W = f \cdot s = 3.92 \times 2 = 7.84 \text{ J}$

Heat produced,

$$H = \frac{W}{J} = \frac{7.84}{4.2} = 1.87 \text{ cal.}$$

**Problem 9.** An aeroplane requires for take off a speed of  $80 \text{ kmh}^{-1}$ , the run on the ground being 100 m. The mass of the aeroplane is  $10^4 \text{ kg}$  and the coefficient of friction between the plane and the ground is 0.2. Assume that the plane accelerates uniformly during the take off. What is the maximum force required by the engine of the plane for take off? [IIT 77]

**Solution.** Here  $u = 0$ ,  $s = 100 \text{ m}$ ,

$$v = 80 \text{ kmh}^{-1} = 80 \times \frac{5}{18} = \frac{200}{9} \text{ ms}^{-1}$$

As  $v^2 - u^2 = 2as$

$$\therefore \left(\frac{200}{9}\right)^2 - 0 = 2a \times 100$$

or  $a = \frac{40000}{81 \times 200} = \frac{200}{81} \text{ ms}^{-2}$

Force required to produce acceleration  $a$ ,

$$F_1 = ma = 10^4 \times \frac{200}{81} = 2.47 \times 10^4 \text{ N}$$

Force required to overcome friction,

$$F_2 = \mu R = \mu mg = 0.2 \times 10^4 \times 9.8 = 1.96 \times 10^4 \text{ N}$$

Maximum force required by the engine for take off,

$$F = F_1 + F_2 = 2.47 \times 10^4 + 1.96 \times 10^4 = 4.43 \times 10^4 \text{ N.}$$

**Problem 10.** A body of mass  $m$  rests on a horizontal floor with which it has a coefficient of static friction  $\mu$ . It is desired to make the body move by applying the minimum possible force  $F$ . Find the magnitude of  $F$  and the direction in which it has to be applied.

**Solution.** As shown in Fig. 5.115, suppose the force  $F$  is applied at an angle  $\theta$  with the horizontal.

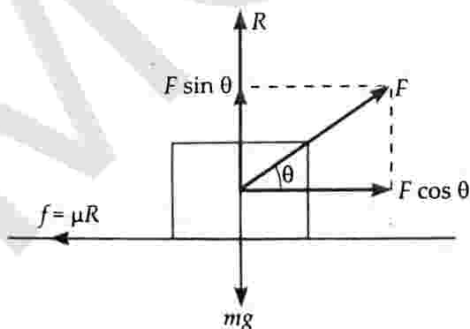

Fig. 5.115

For horizontal equilibrium,

$$F \cos \theta = \mu R \quad \dots(1)$$

For vertical equilibrium,

$$R + F \sin \theta = mg$$

or

$$R = mg - F \sin \theta \quad \dots(2)$$

Substituting this value of  $R$  in (1), we get

$$F \cos \theta = \mu (mg - F \sin \theta) \\ = \mu mg - \mu F \sin \theta$$

or

$$F (\cos \theta + \mu \sin \theta) = \mu mg$$

or

$$F = \frac{\mu mg}{\cos \theta + \mu \sin \theta} \quad \dots(3)$$

For  $F$  to be minimum, the denominator  $(\cos \theta + \mu \sin \theta)$  should be maximum.

$$\therefore \frac{d}{d\theta} (\cos \theta + \mu \sin \theta) = 0$$

or

$$-\sin \theta + \mu \cos \theta = 0$$

or

$$\tan \theta = \mu$$

Then  $\sin \theta = \frac{\mu}{\sqrt{1 + \mu^2}}$  and  $\cos \theta = \frac{1}{\sqrt{1 + \mu^2}}$

Hence  $F_{\min} = \frac{\mu mg}{\frac{1}{\sqrt{1 + \mu^2}} + \frac{\mu^2}{\sqrt{1 + \mu^2}}} = \frac{\mu mg}{\sqrt{1 + \mu^2}}$

Angle which the force makes with the horizontal,

$$\theta = \tan^{-1} \mu.$$

**Problem 11.** The pulleys and strings shown in Fig. 5.116 are smooth and of negligible mass. For the system to remain in equilibrium, what should be the angle  $\theta$ ?

[IIT Screening 01]

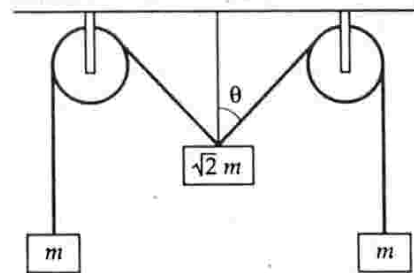

Fig. 5.116

**Solution.** The free body diagrams of the masses  $\sqrt{2}m$  and  $m$  are shown in Fig. 5.117.

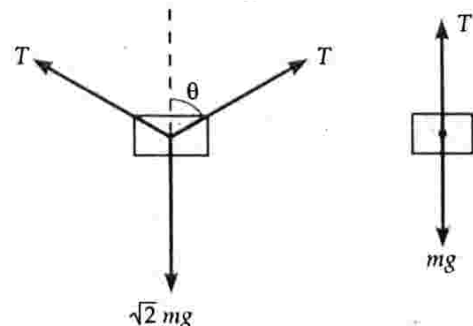

Fig. 5.117



For the equilibrium of mass  $m$ ,

$$mg = T$$

For the equilibrium of mass  $\sqrt{2}m$ ,

$$\sqrt{2}mg = 2T \cos \theta$$

or  $\sqrt{2} \times T = 2T \cos \theta$

or  $\cos \theta = \frac{1}{\sqrt{2}}$  or  $\theta = 45^\circ$ .

**Problem 12.** A string of negligible mass going over a clamped pulley of mass  $m$  supports a block of mass  $M$  as shown in Fig. 5.118. Find the force exerted on the pulley by the clamp. [IIT Screening 01]

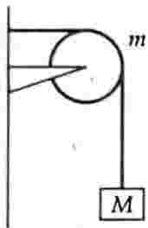

Fig. 5.118

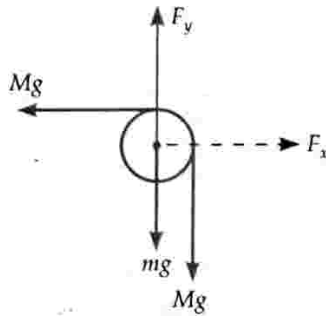

Fig. 5.119

**Solution.** The free body diagram for the pulley is shown in Fig. 5.119.

For the equilibrium of the pulley,

$$F_x = \text{Horizontal component of the force by the clamp on the pulley} = Mg$$

$$F_y = \text{Vertical component of the force by the clamp on the pulley} = (M + m)g$$

The net force exerted on the pulley by the clamp,

$$F = \sqrt{F_x^2 + F_y^2} = g \sqrt{(M + m)^2 + M^2}$$

**Problem 13.** An insect crawls up a hemispherical surface very slowly (see Fig. 5.120). The coefficient of friction between the insect and the surface is  $1/3$ . If the line joining the centre of the hemispherical surface to the insect makes an angle  $\alpha$  with the vertical, find the maximum possible value of  $\alpha$ . [IIT Screening 01]

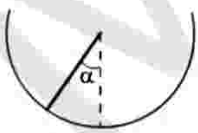

Fig. 5.120

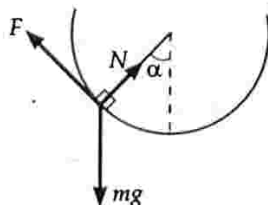

Fig. 5.121

**Solution.** Refer to Fig. 5.121. Balancing horizontal components of the forces, we get,

$$F \cos \alpha = N \sin \alpha$$

or  $\tan \alpha = F / N$ .

For  $\alpha$  to be maximum,  $F$  must be maximum, i.e.,

$$F = \mu N$$

$$\therefore \tan \alpha = \mu = 1/3 \text{ or } \cot \alpha = 3.$$

**Problem 14.** What is the maximum value of the force  $F$  such that the block shown in the arrangement of Fig. 5.122 does not move? [IIT Screening 03]

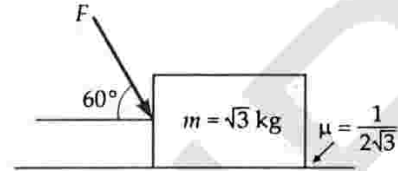

Fig. 5.122

**Solution.** The free body diagram for the block is shown in Fig. 5.123.

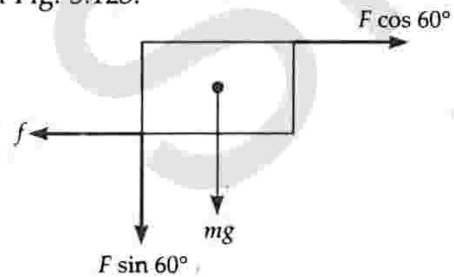

Fig. 5.123

For no motion of the block,

$$F \cos 60^\circ \leq f$$

or  $F \cos 60^\circ \leq \mu N$

or  $F \cos 60^\circ \leq \mu (mg + F \sin 60^\circ)$

or  $\frac{F}{2} \leq \frac{1}{2\sqrt{3}} \left( \sqrt{3} \times g + \frac{F\sqrt{3}}{2} \right)$

or  $\frac{F}{2} \leq g$

$$\therefore F_{\max} = 2g = 2 \times 10 = 20 \text{ N.}$$

**Problem 15.** The driver of a truck travelling with a velocity  $v$  suddenly notices a brick wall in front of him at a distance  $d$ . Is it better for him to apply brakes or to make a circular turn without applying brakes in order to just avoid crashing into the wall? Explain. [Delhi 05; Central Schools 08]

**Solution.** Suppose  $F_B$  force is required in applying brakes to stop the truck in distance  $d$ . Then

$$F_B \times d = \frac{1}{2} mv^2 \text{ or } F_B = \frac{mv^2}{2d}$$

Suppose  $F_T$  force is required in taking a turn of radius  $d$ . Then

$$F_T = \frac{mv^2}{d} = 2F_B \text{ or } F_B = \frac{1}{2} F_T$$

Clearly, it is better to apply brakes than to take circular turn.

**Problem 16.** A smooth block is released at rest on a  $45^\circ$  incline and then slides a distance  $d$ . If the time taken to slide on rough incline is  $n$  times as large as that to slide than on a smooth incline, find the coefficient of friction. [AIEEE 05]

**Solution.** When there is no friction, the block slides down the inclined plane with acceleration,

$$a = g \sin \theta$$

When there is friction, the downward acceleration of the block is

$$a' = g (\sin \theta - \mu \cos \theta)$$

As the block slides a distance  $d$  in each case, so

$$d = \frac{1}{2} at^2 = \frac{1}{2} a' t'^2$$

$$\text{or } \frac{a}{a'} = \frac{t'^2}{t^2} = \frac{(nt)^2}{t^2} = n^2$$

$$\text{or } \frac{g \sin \theta}{g (\sin \theta - \mu \cos \theta)} = n^2$$

$$\text{or } \sin \theta = n^2 \sin \theta - \mu n^2 \cos \theta$$

$$\text{or } \mu n^2 \cos \theta = (n^2 - 1) \sin \theta$$

$$\text{or } \mu = \left(1 - \frac{1}{n^2}\right) \tan \theta = \left(1 - \frac{1}{n^2}\right) \tan 45^\circ$$

$$\text{or } \mu = 1 - \frac{1}{n^2}$$

**Problem 17.** A block of wood of mass 3 kg is resting on the surface of a rough inclined surface, inclined at an angle  $\theta$  as shown in Fig. 5.124.

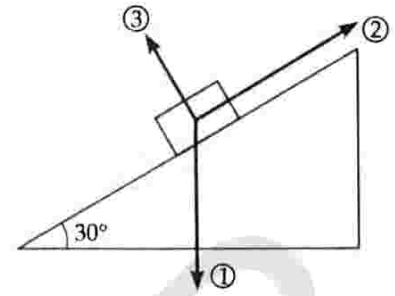

Fig. 5.124

(a) Name the forces (1, 2, 3).

(b) If the coefficient of static friction is 0.2, calculate the value of all the three forces.

(use  $g = 10 \text{ m/s}^2$ )

[Central Schools 08]

**Solution.** (a) Force 1 = Weight of block =  $mg$

Force 2 = Upward applied force for keeping block at rest.

Force 3 = Normal reaction  $R$ .

(b) Here  $\mu = 0.2$ ,  $m = 3 \text{ kg}$ ,  $g = 10 \text{ ms}^{-2}$ ,  $\theta = 30^\circ$ .

$\therefore$  Force 1 =  $mg = 3 \times 10 = 30 \text{ N}$ .

Force 3 = Normal reaction =  $mg \cos \theta$

$$= 3 \times 10 \times \cos 30^\circ = 15\sqrt{3} \text{ N.}$$

Now  $mg \sin \theta = 3 \times 10 \times \sin 30^\circ = 15 \text{ N}$

Friction,  $f = \mu R = 0.2 \times 15\sqrt{3} = 3\sqrt{3} \text{ N}$

$\therefore$  Force 2 =  $mg \sin \theta + f$

$$= 15 + 3\sqrt{3} = 20.2 \text{ N.}$$

## Guidelines to NCERT Exercises

5.1. Give the magnitude and direction of the net force acting on

(a) a drop of rain falling down with a constant speed,

(b) a cork of mass 10 g floating on water,

(c) a kite skilfully held stationary in the sky,

(d) a car moving with a constant velocity of 30 km/h on a rough road, [Delhi 12]

(e) a high-speed electron in space far from all gravitating objects, and free of electric and magnetic fields.

Ans.

(a) As the rain drop is falling down with a constant speed, no net force is acting on it. The weight of the drop is balanced by the upthrust and viscosity of air.

(b) Zero, because the weight of the cork is balanced by the upthrust exerted by water.

(c) As the kite is held stationary, no net force acts on it. The force exerted by air on the kite is balanced by the tension produced in the string.

(d) As the car is moving with a constant velocity, no net force acts on it. The force exerted by the engine is balanced by the friction due to rough road.

(e) As no field (gravitational/electric/magnetic) is acting on the electron, the net force on it is zero.

5.2. A pebble of mass 0.05 kg is thrown vertically upwards. Give the direction and magnitude of the net force on the pebble

(i) during its upward motion.

(ii) during its downward motion.

(iii) at the highest point where it is momentarily at rest.

Do your answers alter if the pebble were thrown at an angle of say  $45^\circ$  with the horizontal direction? Take  $g = 10 \text{ ms}^{-2}$

**Ans.** Here  $m = 0.05 \text{ kg}$ ,  $g = 10 \text{ ms}^{-2}$

- (i) Net force on the pebble =  $mg$   
 $= 0.05 \times 10 = 0.5 \text{ N}$ , vertically downwards
- (ii) Net force on the pebble =  $mg$   
 $= 0.05 \times 10 = 0.5 \text{ N}$ , vertically downwards
- (iii) Net force on the pebble  
 $= mg = 0.05 \times 10 = 0.5 \text{ N}$ , vertically downwards

The answers will not alter if the pebble were thrown at an angle of  $45^\circ$  with the horizontal because the horizontal component of velocity remains constant.

**5.3.** Give the magnitude and direction of the net force acting on a stone of  $0.1 \text{ kg}$ ,

- (i) just after it is dropped from the window of a stationary train.
- (ii) just after it is dropped from the window of a train running at a constant velocity of  $36 \text{ kmh}^{-1}$ .
- (iii) just after it is dropped from the window of a train accelerating with  $1 \text{ ms}^{-2}$ .
- (iv) lying on the floor of a train which is accelerating with  $1 \text{ ms}^{-2}$ , the stone being at rest relative to the train. Neglect air resistance throughout, and take  $g = 10 \text{ ms}^{-2}$ .

**Ans.** Here  $m = 0.1 \text{ kg}$ ,  $g = 10 \text{ ms}^{-2}$

- (i) When the stone is just dropped from the window of a stationary train,  
 $F = mg = 0.1 \times 10 = 1 \text{ N}$ , vertically downwards
- (ii) When the stone is dropped from the window of a train running at a constant velocity, no force acts on the stone due to the motion of the train.  
 $\therefore F = mg = 1 \text{ N}$ , vertically downwards.
- (iii) In the train accelerating with  $1 \text{ ms}^{-2}$ , the stone experiences an additional force,  
 $F' = ma = 0.1 \times 1 = 0.1 \text{ N}$ , along horizontal.  
 As the stone is dropped, the force  $F'$  no longer acts on the stone and so net force on the stone is  
 $F = mg = 1 \text{ N}$ , vertically downwards
- (iv) Here weight of the stone is balanced by the normal reaction of the floor.  
 Acceleration of the stone  
 $=$  Acceleration of the train  $= 1 \text{ ms}^{-2}$   
 $\therefore F = ma = 0.1 \times 1 = 0.1 \text{ N}$ , along horizontal.

**5.4.** One end of a string of length  $l$  is connected to a particle of mass  $m$  and the other to a small peg on a smooth horizontal table. If the particle moves in a circle with speed  $v$  the net force on the particle (directed towards the centre) is :

- (i)  $T$ , (ii)  $T - \frac{mv^2}{l}$ , (iii)  $T + \frac{mv^2}{l}$ , (iv)  $0$ .

$T$  is the tension in the string. Choose the correct alternative.

**Ans.** Alternative (i) is correct. The net force on the particle directed towards the centre is  $T$ . This provides the necessary centripetal force to the particle moving in the circle.

**5.5.** A constant retarding force of  $50 \text{ N}$  is applied to a body of mass  $20 \text{ kg}$  moving initially with a speed of  $15 \text{ ms}^{-1}$ . How long does the body take to stop ?

**Ans.** Here  $F = -50 \text{ N}$ ,  $m = 20 \text{ kg}$ ,  $u = 15 \text{ ms}^{-1}$ ,  $v = 0$

As  $F = ma$

$\therefore a = \frac{F}{m} = \frac{-50}{20} = -2.5 \text{ ms}^{-2}$

Also,  $v = u + at \quad \therefore 0 = 15 - 2.5 \times t$

or  $t = 6 \text{ s}$ .

**5.6.** A constant force acting on a body of mass  $3 \text{ kg}$  changes its speed from  $2 \text{ ms}^{-1}$  to  $3.5 \text{ ms}^{-1}$  in  $25 \text{ s}$ . The direction of motion of the force remains unchanged. What is the magnitude and the direction of the force ? [Delhi 06]

**Ans.** Here  $m = 3 \text{ kg}$ ,  $u = 2 \text{ ms}^{-1}$ ,  $v = 3.5 \text{ ms}^{-1}$ ,  $t = 25 \text{ s}$

As  $v = u + at$

$\therefore 3.5 = 2 + a \times 25$

or  $a = \frac{3.5 - 2}{25} = 0.06 \text{ ms}^{-2}$

Force,  $F = ma = 3 \times 0.06 = 0.18 \text{ N}$

As the applied force increases the speed of the body, it acts in the direction of motion of the body.

**5.7.** A body of mass  $5 \text{ kg}$  is acted upon by two perpendicular forces of  $8 \text{ N}$  and  $6 \text{ N}$ . Give the magnitude and direction of the acceleration of the body.

**Ans.** As shown in Fig. 5.125,

$F_1 = 8 \text{ N}$ ,  $F_2 = 6 \text{ N}$ ,  $m = 5 \text{ kg}$

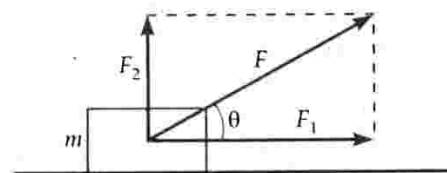

**Fig. 5.125**

The magnitude of the resultant force,

$F = \sqrt{F_1^2 + F_2^2} = \sqrt{8^2 + 6^2} = 10 \text{ N}$

The magnitude of the acceleration produced,

$a = \frac{F}{m} = \frac{10}{5} = 2 \text{ ms}^{-2}$ .

If the force  $F$  makes angle  $\theta$  with  $F_1$ , then

$\cos \theta = \frac{F_1}{F} = \frac{8}{10} = 0.8$

$\therefore \theta = \cos^{-1}(0.8) = 36.87^\circ$ ,

with the  $8 \text{ N}$  force.

**5.8.** The driver of a three wheeler moving with a speed of  $36 \text{ kmh}^{-1}$  sees a child standing in the middle of the road and brings his vehicle to rest in  $4 \text{ s}$  just in time to save the child.

What is the average retarding force on the vehicle? The mass of the three-wheeler is 400 kg and the mass of the driver is 65 kg.

**Ans.** Here  $u = 36 \text{ kmh}^{-1} = 10 \text{ ms}^{-1}$ ,  $v = 0$ ,

$$t = 4 \text{ s}, m = 400 + 65 = 465 \text{ kg}$$

As  $v = u + at$

$$\therefore 0 = 10 + a \times 4 \quad \text{or} \quad a = -2.5 \text{ ms}^{-2}$$

Magnitude of the retarding force on the vehicle is

$$F = ma = 465 \times 2.5 = \mathbf{1162.5 \text{ N.}}$$

**5.9.** A rocket with a lift off mass 20,000 kg is blasted upwards with an initial acceleration of  $5 \text{ ms}^{-2}$ . Calculate the initial thrust of the blast.

**Ans.** Initial thrust = upthrust required to impart acceleration  $a$  + upthrust required to overcome gravitational pull

$$\begin{aligned} &= ma + mg = m(a + g) \\ &= 20,000(5 + 9.8) = 20,000 \times 14.8 \text{ N} \\ &= \mathbf{2.96 \times 10^5 \text{ N.}} \end{aligned}$$

**5.10.** A body of mass 0.4 kg moving with a constant speed of  $10 \text{ ms}^{-1}$  to the north is subjected to a constant force of 8 N directed towards the south for 30 s. Take the instant the force is applied to be  $t = 0$ , the position of the body at that time to be  $x = 0$  and predict its position at  $t = -5 \text{ s}$ , 25 s and 100 s.

**Ans.** We take south to north as the positive direction. Then  $u = +10 \text{ ms}^{-1}$  (due north),  $F = -8 \text{ N}$  (due south),  $t = 30 \text{ s}$ ,  $m = 0.4 \text{ kg}$

$$a = \frac{F}{m} = \frac{-8}{0.4} = -20 \text{ ms}^{-2}$$

(i) At  $t = -5 \text{ s}$ , no force acts on the particle.

$$\therefore x = ut = 10 \times (-5) = \mathbf{-50 \text{ m.}}$$

(ii) At  $t = 25 \text{ s}$ , the position of the particle will be

$$\begin{aligned} x &= ut + \frac{1}{2}at^2 = 10 \times 25 - \frac{1}{2} \times 20 \times (25)^2 \\ &= 250 - 6250 = \mathbf{-6000 \text{ m} = -6 \text{ km.}} \end{aligned}$$

(iii) At  $t = 100 \text{ s}$ , there is no force because force stops acting after  $t = 30 \text{ s}$ .

$\therefore$  Distance covered during first 30 s is

$$\begin{aligned} x_1 &= ut + \frac{1}{2}at^2 = 10 \times 30 - \frac{1}{2} \times 20 \times (30)^2 \\ &= \mathbf{-8700 \text{ m}} \end{aligned}$$

Velocity acquired at  $t = 30 \text{ s}$  will be

$$v = u + at = 10 - 20 \times 30 = \mathbf{-590 \text{ ms}^{-1}}$$

Distance covered in next 70 s with constant velocity of  $-590 \text{ ms}^{-1}$  is

$$x_2 = vt = -590 \times 70 = \mathbf{-41300 \text{ m}}$$

$\therefore$  Position of the particle at  $t = 30 \text{ s}$  is

$$\begin{aligned} x_1 + x_2 &= -8700 - 41300 \\ &= \mathbf{-50,000 \text{ m} = -50 \text{ km.}} \end{aligned}$$

**5.11.** A truck starts from rest and accelerates uniformly with  $2.0 \text{ ms}^{-2}$ . At  $t = 10 \text{ s}$ , a stone is dropped by a person

standing on the top of the truck (6 m high from the ground). What are the (i) velocity, and (ii) acceleration of the stone at  $t = 11 \text{ s}$ ? Neglect air resistance. Take  $g = 10 \text{ ms}^{-2}$

**Ans.** Here  $u = 0$ ,  $a = 2 \text{ ms}^{-2}$ ,  $g = 10 \text{ ms}^{-2}$ ,  $t = 10 \text{ s}$ .

(i) During first 10 s, the horizontal component of the velocity is

$$v_x = u + at = 0 + 2 \times 10 = 20 \text{ ms}^{-1}$$

From 10 s to 11 s (i.e., for 1 s), the vertical component of the velocity is

$$v_y = u + gt = 0 + 10 \times 1 = 10 \text{ ms}^{-1}$$

$\therefore$  Resultant velocity,

$$v = \sqrt{v_x^2 + v_y^2} = \sqrt{(20)^2 + (10)^2} = 10\sqrt{5} = \mathbf{22.4 \text{ ms}^{-1}}$$

The direction of resultant velocity with the horizontal is given by

$$\tan \theta = \frac{v_y}{v_x} = \frac{10}{20} = \frac{1}{2} \quad \text{or} \quad \theta = \tan^{-1}(1/2) = \mathbf{26.7^\circ}$$

(ii) As there is no horizontal acceleration, the only acceleration is vertical.

$\therefore$  Vertically downward acceleration =  $g = 10 \text{ ms}^{-2}$ .

**5.12** A bob of mass 0.1 kg hung from the ceiling of a room by a string 2 m long is set into oscillation. The speed of the bob at its mean position is  $1 \text{ ms}^{-1}$ . What is the trajectory of the bob if the string is cut when the bob is (a) at one of its extreme positions, (b) at its mean position?

**Ans.**

(a) At the extreme position the speed of bob is zero. The bob is momentarily at rest. If the string is cut, the bob will fall vertically downwards.

(b) At the mean position, the bob has a horizontal velocity. If the string is cut, it will fall along a parabolic path under the effect of gravity.

**5.13.** A man weighs 70 kg. He stands on a weighing machine in a lift, which is moving

(i) upwards with a uniform speed of  $10 \text{ ms}^{-1}$ .

(ii) downwards with a uniform acceleration of  $5 \text{ ms}^{-2}$ .

(iii) upwards with a uniform acceleration of  $5 \text{ ms}^{-2}$ .

What would be the readings on the scale in each case? What would be the reading, if the lift mechanism failed and it came down freely under gravity? [Delhi 05C; Central Schools 08]

**Ans.** The apparent weight measured by the weighing machine is the measure of the reaction  $R$  exerted on the man due to the lift.

(i) When the lift moves upward with uniform velocity, reaction of the lift is equal to the weight of the man.

$\therefore$  Apparent weight,

$$R = mg = 70 \times 9.8 = \mathbf{686 \text{ N} = 70 \text{ kg wt}}$$

(ii) When the lift moves downwards with uniform acceleration,

$$a = 5 \text{ ms}^{-2}$$

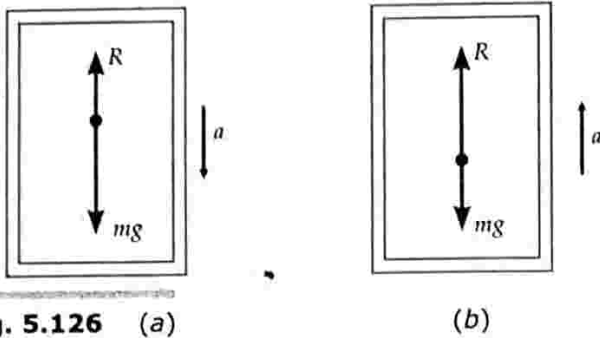

Fig. 5.126 (a)

(b)

Resultant downward force,

$$F = mg - R \quad \text{or} \quad ma = mg - R$$

∴ Apparent weight,

$$R = m(g - a) = 70(9.8 - 5) \\ = 70 \times 4.8 = 336 \text{ N} = 34.29 \text{ kg wt.}$$

(iii) When the lift moves upwards with uniform acceleration,  $a = 5 \text{ ms}^{-2}$

Resultant upward force,

$$F = R - mg \quad \text{or} \quad ma = R - mg$$

∴ Apparent weight,

$$R = m(g + a) = 70(9.8 + 5) \\ = 70 \times 14.8 = 1036 \text{ N} = 105.7 \text{ kg wt.}$$

When the lift falls freely under gravity,  $a = g$

∴ Apparent weight,  $R = m(g - a) = m(g - g) = 0$

This is the condition of weightlessness.

5.14. Fig. 5.127 shows the position-time graph of a particle of mass 4 kg. What is the (i) force acting on the particle for  $t < 0, t \gg 4 \text{ s}, 0 < t < 4 \text{ s}$ ? (ii) impulse at  $t = 0$  and  $t = 4 \text{ s}$ ? Assume that the motion is one dimensional. [Delhi 09]

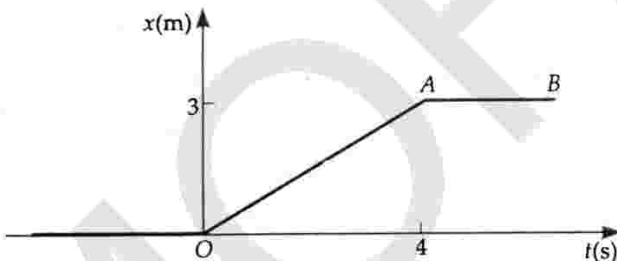

Fig. 5.127

Ans. (i) For  $t < 0$  and  $t > 4 \text{ s}$ , the position of the particle is not changing i.e. the particle is at rest. So no force is acting on the particle during these intervals.

For  $0 < t < 4 \text{ s}$ , the position of the particle is continuously changing. As the position-time graph is a straight line, the motion of the particle is uniform, so acceleration,  $a = 0$ . Hence no force acts on the particle during this interval also.

(ii) Before  $t = 0$ , the particle is at rest, so  $u = 0$

After  $t = 0$ , the particle has a constant velocity,

$$v = \text{Slope of } OA = \frac{3}{4} \text{ ms}^{-1}$$

∴ At  $t = 0$ ,

Impulse = Change in momentum

$$= m(v - u) = 4 \left( \frac{3}{4} - 0 \right) = 3 \text{ kg ms}^{-1}.$$

Before  $t = 4 \text{ s}$ , the particle has a constant velocity,

$$u = \text{Slope of } OA = \frac{3}{4} \text{ ms}^{-1}$$

After  $t = 4 \text{ s}$ , the particle is at rest, so  $v = 0$

At  $t = 4 \text{ s}$ ,

$$\text{Impulse} = m(v - u) = 4 \left( 0 - \frac{3}{4} \right) = -3 \text{ kg ms}^{-1}.$$

5.15. Two bodies of masses 10 kg and 20 kg respectively kept on a smooth, horizontal surface are tied to the ends of a light string. A horizontal force  $F = 600 \text{ N}$  is applied to (i) B (ii) A along the direction of string. What is the tension in the string in each case? [Central Schools 04, 09]

Ans. Here  $F = 600 \text{ N}$ ,  $m_1 = 10 \text{ kg}$ ,  $m_2 = 20 \text{ kg}$

Let  $T$  be the tension in the string and  $a$  be the acceleration produced in the system, in the direction of applied force  $F$ . Then

$$a = \frac{F}{m_1 + m_2} = \frac{600}{10 + 20} = 20 \text{ ms}^{-2}.$$

(i) Suppose the pull  $F$  is applied on the body B of mass 20 kg, as shown in Fig. 5.128(a).

Let  $T_1$  be the tension in the string. As  $T_1$  is the only force acting on mass 10 kg, so

$$T_1 = m_1 a = 10 \times 20 = 200 \text{ N}.$$

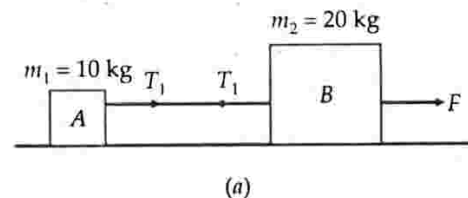

(a)

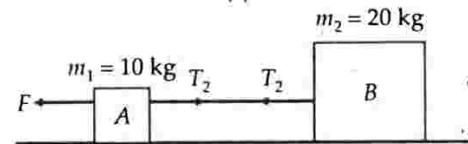

(b)

Fig. 5.128

(ii) When the pull  $F$  is applied on body A of mass 10 kg [Fig. 5.128(b)], tension in the string will be

$$T_2 = m_2 a = 20 \times 20 = 400 \text{ N}.$$

Clearly, the tension depends on which mass end the pull is applied.

5.16. Two masses 8 kg and 12 kg are connected at the two ends of a light inextensible string that goes over a frictionless pulley. Find the acceleration of the masses and the tension in the string when the masses are released. [Delhi 10]

Ans. Here  $m = 8 \text{ kg}$ ,  $M = 12 \text{ kg}$ ,  $g = 10 \text{ ms}^{-2}$

From the derivation of connected motion in Q.45 on page 5.31, we have

$$a = \frac{M - m}{M + m} \cdot g = \frac{12 - 8}{12 + 8} \times 10 = 2 \text{ ms}^{-2}$$

$$T = \frac{2Mm}{M + m} \cdot g = \frac{2 \times 12 \times 8}{12 + 8} \times 10 = 96 \text{ N.}$$

5.17. A nucleus is at rest in the laboratory frame of reference. Show that if it disintegrates into two smaller nuclei, the products must move in opposite directions.

Ans. Let  $M$  be the mass of the nucleus at rest. Suppose it disintegrates into two smaller nuclei of masses  $m_1$  and  $m_2$  which move with velocities  $v_1$  and  $v_2$  respectively.

∴ Momentum before disintegration =  $M \times 0 = 0$

Momentum after disintegration =  $m_1 v_1 + m_2 v_2$

According to the law of conservation of momentum,

$$m_1 v_1 + m_2 v_2 = 0 \quad \text{or} \quad v_2 = -\frac{m_1}{m_2} \cdot v_1$$

As masses  $m_1$  and  $m_2$  cannot be negative, the above equation shows that  $v_1$  and  $v_2$  must have opposite signs i.e. the two products must move in opposite directions.

5.18. Two billiard balls each of mass 0.05 kg moving in opposite directions with speed of  $6 \text{ ms}^{-1}$  collide and rebound with the same speed. What is the impulse imparted to each ball by the other?

Ans. Fig. 5.129(a) and 5.129(b) show the situations of the two balls before and after the collision.

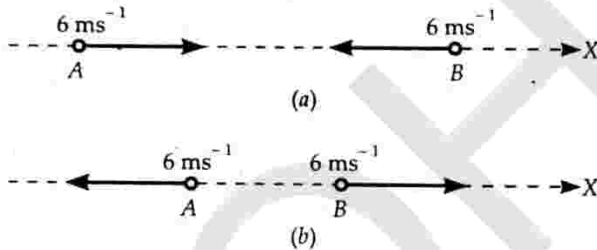

Fig. 5.129

Impulse imparted to one ball by the other = Change in momentum.

For ball A :  $p_i$  = Momentum before collision

$$= 0.05 \times 6 = 0.3 \text{ kg ms}^{-1}$$

$p_f$  = Momentum after collision

$$= 0.05 \times (-6) = -0.3 \text{ kg ms}^{-1}.$$

∴ Impulse imparted to ball A due to ball B

$$= p_f - p_i = -0.3 - 0.3 = -0.6 \text{ kg ms}^{-1}.$$

For ball B :  $p_i$  = Momentum before collision

$$= 0.05 \times (-6) = -0.3 \text{ kg ms}^{-1}$$

$p_f$  = Momentum after collision

$$= 0.05 \times (6) = 0.3 \text{ kg ms}^{-1}$$

∴ Impulse imparted to ball B due to ball A

$$= p_f - p_i = 0.3 - (-0.3) = 0.6 \text{ kg ms}^{-1}.$$

5.19. A shell of mass 0.02 kg is fired by a gun of mass 100 kg. If the muzzle speed of the shell is  $80 \text{ ms}^{-1}$ , what is the recoil speed of the gun?

Ans. Mass of shell,  $m = 0.02 \text{ kg}$

Mass of gun,  $M = 100 \text{ kg}$

Speed of shell,  $v = 80 \text{ ms}^{-1}$

Let  $V$  be the recoil speed of the gun. According to the law of conservation of momentum,

Initial momentum = Final momentum

$$\text{or} \quad 0 = mv + MV$$

$$\therefore V = -\frac{mv}{M} = -\frac{0.02 \times 80}{100} = -0.016 \text{ ms}^{-1}.$$

Negative sign indicates that the gun moves backward as the bullet moves forward.

5.20. A batsman deflects a ball by an angle of  $45^\circ$  without changing its initial speed which is equal to  $54 \text{ kmh}^{-1}$ . What is the impulse imparted to the ball? Mass of the ball is 0.15 kg.

Ans. Speed of the ball =  $54 \text{ kmh}^{-1} = 15 \text{ ms}^{-1}$

Let  $\vec{v}_1$  and  $\vec{v}_2$  be the velocities of the ball before and after deflection.

As the speed of the ball remains unchanged even after deflection, so

$$|\vec{v}_1| = |\vec{v}_2| = 15 \text{ ms}^{-1}$$

In Fig. 5.130,  $\vec{AO} = \vec{v}_1$  and  $\vec{OB} = \vec{v}_2$ . Clearly, the change in velocity of the ball is

$$\vec{v}_2 - \vec{v}_1 = \vec{v}_2 + (-\vec{v}_1) = \vec{OB} + \vec{BC} = \vec{OC} = \vec{v} \text{ (say)}$$

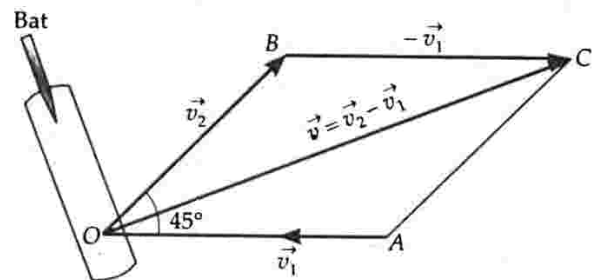

Fig. 5.130

$$\text{Then} \quad v = \sqrt{v_1^2 + v_2^2 + 2v_1 v_2 \cos 45^\circ}$$

$$= \sqrt{(15)^2 + (15)^2 + 2 \times 15 \times 15 \times (1/\sqrt{2})}$$

$$= \sqrt{225 + 225 + 225\sqrt{2}} = 27.72 \text{ ms}^{-1}$$

Impulse imparted to the ball

= Mass  $\times$  Change in velocity of the ball

$$= 0.15 \times 27.72 = 4.16 \text{ kg ms}^{-1}$$

Impulse is imparted along  $\vec{v}$ . As the velocity  $\vec{v}$  is the resultant of two velocities  $-\vec{v}_1$  and  $\vec{v}_2$ , which have equal

magnitude, so  $\vec{v}$  equally divides the angle between  $\vec{v}_1$  and  $\vec{v}_2$  i.e. impulse is directed along the bisector of initial and final directions.

5.21. A stone of 0.25 kg tied to the end of a string is whirled round in a circle of radius 1.5 m with a speed of 40 rev./min in a horizontal plane. What is the tension in the string? What is the maximum speed with which the stone can be whirled around if the string can withstand a maximum tension of 200 N?

[Chandigarh 04]

Ans. (i) Here  $m = 0.25$  kg,  $r = 1.5$  m

$$v = 40 \text{ rev min}^{-1} = 40 \text{ rev (60 s)}^{-1} = \frac{2}{3} \text{ rps}$$

$$\omega = 2\pi v = 2\pi \times \frac{2}{3} = \frac{4\pi}{3} \text{ rad s}^{-1}$$

Tension in the string = Centripetal force

$$\text{or } T = mr\omega^2 = 0.25 \times 1.5 \times \left(\frac{4\pi}{3}\right)^2 = 6.6 \text{ N.}$$

(i) Given  $T_{\text{max}} = 200$  N

$$\text{As } \frac{mv_{\text{max}}^2}{r} = T_{\text{max}}$$

$$\therefore v_{\text{max}} = \sqrt{\frac{T_{\text{max}} \times r}{m}} = \sqrt{\frac{200 \times 1.5}{0.25}} = 34.6 \text{ ms}^{-1}.$$

5.22. A stone tied to the end of string is whirled round in a circle in a horizontal plane. If the speed of the stone is increased beyond the maximum permissible value, and the string breaks suddenly, which of the following correctly describes the trajectory of the stone after the string breaks :

- the stone jerks radially outwards,
- the stone flies off tangentially from the instant the string breaks,
- the stone flies off at an angle with the tangent whose magnitude depends on the speed of the particle?

Ans. The alternative (b) is correct. When the string breaks, the stone flies off tangentially from the instant, the string breaks. This is because the velocity at any point is directed along the tangent at that point.

5.23. Explain why

- a horse cannot pull a cart and run in empty space,
- passengers are thrown forward from their seats when a speeding bus stops suddenly,
- it is easier to pull a lawn mower than to push it,
- a cricketer moves his hands backwards while holding a catch.

[Chandigarh 09]

Ans. (a) For pulling a cart or for running, the horse pushes the earth with its feet and reaction of the earth makes it move in the forward direction. Since in empty space there is no reaction force, therefore the horse cannot run in empty space.

(b) Refer to solution of Problem 7 on page 5.62.

(c) Refer to Figs. 5.96 and 5.97. A lawn mower is pulled or pushed by applying force at an angle. The vertical component of the applied force reduces the effective weight of the mower in case of pull and increases the effective weight in case of push. Consequently, the normal reaction and hence the force of friction is less in case of pull than that in push. Hence it is easier to pull a lawn mower than to push it.

(d) When the ball is caught, the impulse received by the hands is equal to the product of the force exerted by the ball and the time taken to complete the catch. By moving the hands backwards, the cricketer increases the time of catch. The force exerted on his hands becomes much smaller and it does not hurt him.

5.24. Fig. 5.131 below shows the position-time graph of a particle of mass 0.04 kg. Suggest a suitable physical context for this motion. What is the time between two consecutive impulses received by the particle? What is the magnitude of each impulse?

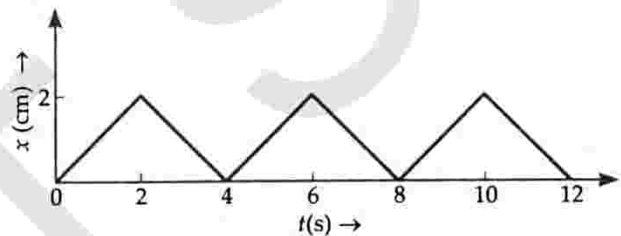

Fig. 5.131

Ans. Fig. 5.131 shows that (i) the direction of motion of the particle changes after every 2 s and (ii) in both directions, the particle moves with a uniform speed.

Before  $t = 2$  s, velocity of the particle,

$$u = \text{Slope of } x-t \text{ graph} \\ = \frac{(2-0) \text{ cm}}{(2-0) \text{ s}} = 1 \text{ cms}^{-1} = 0.01 \text{ ms}^{-1}$$

After  $t = 2$  s, velocity of the particle,

$$v = \frac{(0-2) \text{ cm}}{(4-2) \text{ s}} = -1 \text{ cms}^{-1} = -0.01 \text{ ms}^{-1}$$

Mass of particle,  $m = 0.04$  kg

At  $t = 2$  s, magnitude of impulse

$$= \text{Change in momentum} = m(u-v) \\ = 0.04 [0.01 - (-0.01)] \text{ kg ms}^{-1} \\ = 8 \times 10^{-4} \text{ kg ms}^{-1}.$$

The given  $x-t$  graph may represent the repeated rebounding of a particle between two walls situated at  $x = 0$  and  $x = 2$  cm. The particle receives an impulse of  $8 \times 10^{-4} \text{ kg ms}^{-1}$  after every 2 s.

5.25. Fig. 5.132 shows a man standing stationary with respect to a horizontal conveyor belt that is accelerating with  $1 \text{ ms}^{-2}$ . What is the net force on the man? If the coefficient of static friction between the man's shoes and the belt is 0.2, upto what acceleration of the belt can the man continue to be stationary relative to the belt? Mass of the man = 65 kg.

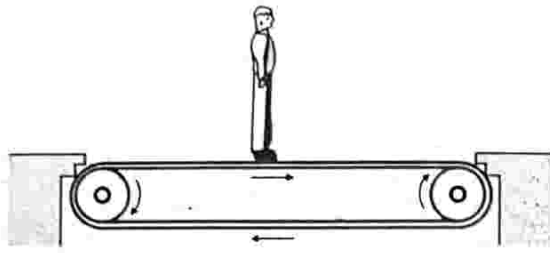

Fig. 5.132

Ans. As the man is standing stationary w.r.t. the belt,

∴ Acceleration of the man  
= Acceleration of the belt =  $a = 1 \text{ ms}^{-2}$

Mass of the man,  $m = 65 \text{ kg}$

Net force on the man =  $ma = 65 \times 1 = 65 \text{ N}$ .

Given coefficient of friction,  $\mu = 0.2$

∴ Limiting friction,  $f = \mu R = \mu mg$

If the man remains stationary w.r.t. the maximum acceleration  $a'$  of the belt, then

$$ma' = f = \mu mg$$

∴  $a' = \mu g = 0.2 \times 9.8 = 1.96 \text{ ms}^{-2}$ .

5.26. A stone of mass  $m$  tied to the end of a string is revolved in a vertical circle of radius  $R$ . The net forces at the lowest and highest points of the circle directed vertically downwards are :

Lowest Point	Highest Point
(i) $mg - T_1$	$mg + T_2$
(ii) $mg + T_1$	$mg - T_2$
(iii) $mg + T_1 - (mv_1^2)/R$	$mg - T_2 + (mv_2^2)/R$
(iv) $mg - T_1 - (mv_1^2)/R$	$mg + T_2 + (mv_2^2)/R$

Here  $T_1, T_2$  (and  $v_1, v_2$ ) denote the tension in the string (and the speed of the stone) at the lowest and the highest point respectively. Choose the correct alternative.

Ans. The alternative (i) is correct because the net force at the lowest point  $L$  is  $F_L = mg - T_1$ , and the net force at highest point  $H$  is  $F_H = mg + T_2$ .

5.27. A helicopter of mass  $1000 \text{ kg}$  rises with a vertical acceleration of  $15 \text{ ms}^{-2}$ . The crew and the passengers weigh  $300 \text{ kg}$ . Give the magnitude and direction of

- (i) force on the floor by the crew and passengers.
- (ii) action of the rotor of the helicopter on the surrounding air.
- (iii) force on the helicopter due to the surrounding air.

Take  $g = 10 \text{ ms}^{-2}$ . [Delhi 03]

Ans. Mass of helicopter,  $M = 1000 \text{ kg}$

Mass of the crew and passengers,  $m = 300 \text{ kg}$

Vertically upward acceleration,  $a = 15 \text{ ms}^{-2}$

(i) Force on the floor by the crew and passengers,

$$F = \text{Apparent weight} = m(g + a) = 300(10 + 15) = 7500 \text{ N, vertically downwards.}$$

(ii) Action of the rotor of the helicopter on the surrounding air

$$\begin{aligned} &= \text{Apparent weight of the helicopter, crew and passengers} \\ &= (M + m)(g + a) = (1000 + 300)(10 + 15) \\ &= 32500 \text{ N, vertically downwards.} \end{aligned}$$

(iii) Force on the helicopter due to the surrounding air is equal and opposite to the action of the rotor of the helicopter on the surrounding air.

∴ Force on surrounding air  
=  $32500 \text{ N}$ , vertically upwards.

5.28. A stream of water flowing horizontally with a speed of  $15 \text{ ms}^{-1}$  gushes out of a tube of cross-sectional area  $10^{-2} \text{ m}^2$ , and hits at a vertical wall nearby. What is the force exerted on the wall by the impact of water, assuming it does not rebound?

Ans. Here  $u = 15 \text{ ms}^{-1}$ ,  $v = 0$ ,  $t = 1 \text{ s}$ ,  $A = 10^{-2} \text{ m}^2$

Density of water =  $1000 \text{ kgm}^{-3}$

$$m = \frac{\text{Volume} \times \text{density}}{\text{Time}} = \frac{\text{Area} \times \text{distance} \times \text{density}}{\text{Time}}$$

$$= \text{Area} \times \text{velocity} \times \text{density}$$

$$= Au\rho = 10^{-2} \times 15 \times 1000 = 150 \text{ kg}$$

Force exerted by the wall on water,

$$F = ma = m \left( \frac{v - u}{t} \right) = 150 \times \frac{0 - 15}{1} = -2250 \text{ N}$$

Force exerted on the wall by the impact of water,

$$F' = -F = 2250 \text{ N.}$$

5.29. Ten one-rupee coins are put on top of each other on a table. Each coin has a mass  $m \text{ kg}$ . Give the magnitude and direction of

- (i) the force on the 7<sup>th</sup> coin (counted from the bottom) due to all the coins on its top.
- (ii) the force on the 7<sup>th</sup> coin by the eighth coin.
- (iii) the reaction of the 6<sup>th</sup> coin on the 7<sup>th</sup> coin.

[Central Schools 09]

Ans. (i) Force on the 7th coin

$$= \text{Force due to 3 coins on its top} = 3mg.$$

(ii) Force on the 7th coin by the 8th coin

$$= \text{Masses of 8th, 9th and 10th coins} \times g = 3mg$$

(iii) Reaction of the 6th coin on the 7th coin

$$= \text{Force on the 6th coin due to 7th coin} = 4mg.$$

5.30. An aircraft executes a horizontal loop at a speed of  $720 \text{ kmh}^{-1}$  with its wings banked at  $15^\circ$ . What is the radius of the loop? [Central Schools 07]

Ans. Here  $\theta = 15^\circ$ ,  $g = 9.8 \text{ ms}^{-2}$

$$v = 720 \text{ kmh}^{-1} = \frac{720 \times 5}{18} = 200 \text{ ms}^{-1}$$

As  $\tan \theta = \frac{v^2}{rg}$



$$\begin{aligned} \therefore r &= \frac{v^2}{g \tan \theta} = \frac{200 \times 200}{9.8 \times \tan 15^\circ} \\ &= \frac{200 \times 200}{9.8 \times 0.2679} = 15.24 \times 10^3 \text{ m} = \mathbf{15.24 \text{ km}}. \end{aligned}$$

**5.31.** A train runs along an unbanked circular track of radius 30 m at a speed of  $54 \text{ kmh}^{-1}$ . The mass of the train is  $10^6 \text{ kg}$ . What provides the centripetal force required for this purpose? The engine or the rails? The outer or the inner rail? Which rail will wear out faster, the outer or the inner rail? What is the angle of banking required to prevent wearing out of the rails?

**Ans.** Here

$$r = 30 \text{ m}, v = 54 \text{ kmh}^{-1} = 15 \text{ ms}^{-1}, m = 10^6 \text{ kg}$$

The centripetal force required for the purpose is provided by the lateral thrust by the outer rail on the flanges of the wheels. By Newton's third law of motion, the train exerts an equal and opposite thrust on the outer rail, causing its wear and tear.

$$\tan \theta = \frac{v^2}{rg} = \frac{(15)^2}{30 \times 9.8} = 0.7653$$

$\therefore$  Angle of banking,  $\theta = 37.4^\circ$ .

**5.32.** A block of mass 25 kg is raised by a 50 kg man in two different ways as shown in Fig. 5.133. What is the action on the floor by the man in the two cases? If the floor yields to a normal force of 700 N, which mode should the man adopt to lift the block without the floor yielding?

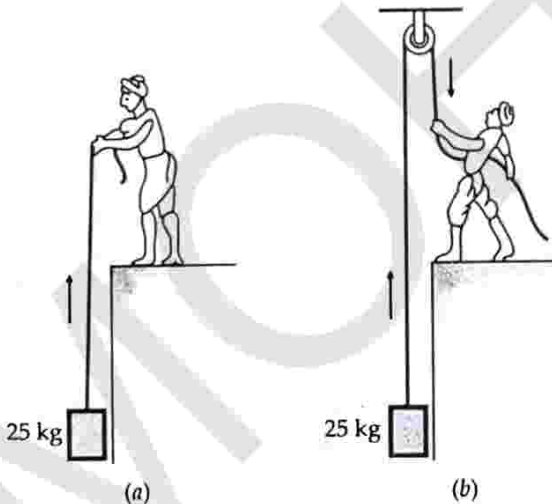

**Fig. 5.133**

**Ans.** In mode (a), the man applies force equal to 25 kg wt in the upward direction. According to Newton's third law of motion, there will be a downward force of reaction on the floor.

$$\begin{aligned} \therefore \text{Total action on the floor by the man} &= 50 \text{ kg wt} + 25 \text{ kg wt} = 75 \text{ kg wt} \\ &= 75 \times 9.8 \text{ N} = \mathbf{735 \text{ N}}. \end{aligned}$$

In mode (b), the man applies a downward force equal to 25 kg wt. According to Newton's third law, the reaction will be in the upward direction.

$$\begin{aligned} \therefore \text{Total action on the floor by the man} &= 50 \text{ kg wt} - 25 \text{ kg wt} = 25 \text{ kg wt} = 25 \times 9.8 \text{ N} = \mathbf{245 \text{ N}}. \end{aligned}$$

As the floor yields to a downward force of 700 N, so the man should adopt mode (b).

**5.33.** A monkey of mass 40 kg climbs on a rope which can stand a maximum tension of 600 N [Fig. 5.134]. In which of the following cases will the rope break: the monkey

- (i) climbs up with an acceleration of  $6 \text{ ms}^{-2}$
- (ii) climbs down with an acceleration of  $4 \text{ ms}^{-2}$
- (iii) climbs up with a uniform speed of  $5 \text{ ms}^{-1}$
- (iv) falls down the rope nearly freely under gravity?

Take  $g = 10 \text{ ms}^{-2}$ . Ignore the mass of the rope.

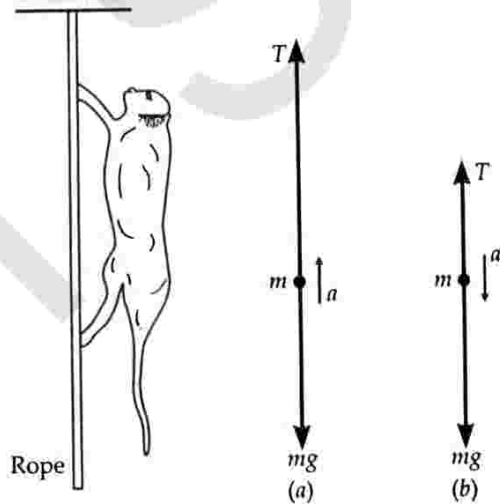

**Fig. 5.134**

**Fig. 5.135**

**Ans.** (i) When the monkey climbs up with an acceleration  $a = 6 \text{ ms}^{-2}$ , the tension  $T$  in the string must be greater than the weight of the monkey [Fig. 5.135(a)],

$$T - mg = ma$$

or  $T = m(g + a) = 40(10 + 6) = \mathbf{640 \text{ N}}$ .

(ii) When the monkey climbs down with an acceleration,  $a = 4 \text{ ms}^{-2}$  [Fig. 5.135(b)],

$$mg - T = ma$$

or  $T = m(g - a) = 40(10 - 4) = \mathbf{240 \text{ N}}$ .

(iii) When the monkey climbs up with uniform speed,

$$T = mg = 40 \times 10 = \mathbf{400 \text{ N}}$$

(iv) When the monkey falls down the rope nearly freely,  $a = g$

$$\therefore T = m(g - a) = m(g - g) = \mathbf{0}$$

As the tension in the rope in case (i) is greater than the maximum permissible tension (600 N), so the rope will break in case (i) only.

**5.34.** Two bodies A and B of masses 5 kg and 10 kg in contact with each other rest on a table against a rigid partition. The coefficient of friction between the bodies and the table is 0.15. A force of 200 N is applied horizontally at A. What are (i) the reaction of the partition (ii) the action-reaction forces between A and B? What happens when the partition is removed? Does answers to (ii) change, when the bodies are in motion? Ignore difference between  $\mu_s$  and  $\mu_k$ .

**Ans.** Mass of body A,

$$m_A = 5 \text{ kg}$$

Mass of body B,

$$m_B = 10 \text{ kg}$$

Coefficient of friction,

$$\mu = 0.15$$

Applied force,  $P = 200 \text{ N}$

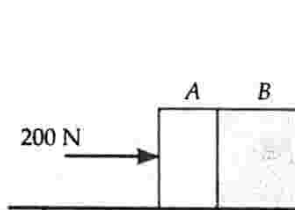

**Fig. 5.136**

(i) Force of limiting friction is

$$f = \mu R = \mu (m_1 + m_2) g \\ = 0.15 \times (5 + 10) \times 9.8 = 22.05 \text{ N}$$

(towards left)

When a force of 200 N is applied, the net force exerted on the partition is

$$P' = P - f = 200 - 22.05 = 177.95 \text{ N}$$

(towards right)

Reaction of the partition = 177.95 N (towards left)

(ii) Force of limiting friction on body A is

$$f_1 = \mu m_1 g = 0.15 \times 5 \times 9.8 = 7.35 \text{ N}$$

Net force exerted by body A on body B is

$$P_1 = P - f_1 = 200 - 7.35 = 192.65 \text{ N}$$

(towards right)

Reaction of body B on A = 192.65 N (towards left)

**When the partition is removed.** The system of the two bodies moves under the action of the net force,

$$P' = 177.95 \text{ N}$$

Acceleration produced in the system,

$$a = \frac{P'}{m_1 + m_2} = \frac{177.95}{5 + 10} = 11.86 \text{ ms}^{-2}$$

Force producing motion in the body A

$$= m_1 a = 5 \times 11.86 = 59.3 \text{ N}$$

Net force exerted by A on B after the removal of partition

$$= P_1 - 59.3 = 192.65 - 59.3 = 133.35 \text{ N}$$

(towards right)

Reaction of the body B on A = 133.5 N.

(towards left)

**5.35.** A block of mass 15 kg is placed on a long trolley. The coefficient of friction between the block and the trolley is 0.18. The trolley accelerates from rest with  $0.5 \text{ ms}^{-2}$  for 20 s and then moves with uniform velocity. Discuss the motion of the block as viewed by (i) a stationary observer on the ground (ii) an observer moving with the trolley.

**Ans.** Mass of block,  $m = 15 \text{ kg}$

$$\mu_s = 0.18, a = 0.5 \text{ ms}^{-2}, t = 20 \text{ s}$$

Maximum value of static friction,

$$f_{ms} = \mu_s R = \mu_s mg = 0.18 \times 15 \times 9.8 = 26.46 \text{ N}$$

Force acting on the block during the accelerated motion,

$$F = ma = 15 \times 0.5 = 7.5 \text{ N}$$

As  $f_{ms} > F$ , so the block does not move. It remains at rest w.r.t. the trolley, even when it is accelerated. When the trolley moves with uniform velocity, acceleration is zero and hence no force is acting on the trolley.

(i) The stationary observer will see the accelerated and the uniform motions.

(ii) When the observer is in the trolley, he is in an accelerated or non-inertial frame. The laws of motion are not applicable. But during uniform motion he will see that the block is at rest w.r.t. him.

**5.36.** The rear side of a truck is open and a box of 40 kg mass is placed 5 m away from the open end as shown in Fig. 5.137. The coefficient of friction between the box and the surface below it is 0.15. On a straight road, the truck starts from rest and accelerates with  $2 \text{ ms}^{-2}$ . At what distance from the starting point does the box fall off the truck? Ignore the mass of the box.

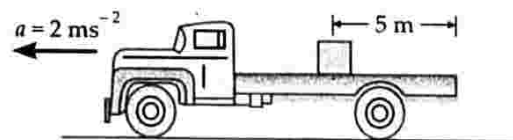

**Fig. 5.137**

**Ans.** Mass of box,  $m = 40 \text{ kg}$

Acceleration of truck,

$$a = 2 \text{ ms}^{-2}$$

Distance of the box from the rear end,

$$s = 5 \text{ m}$$

Coefficient of friction,

$$\mu = 0.15$$

As the box is in an accelerated frame, it experiences a backward force,

$$F = ma$$

Motion of the box is opposed by the frictional force,

$$f = \mu R = \mu mg$$

∴ Net force on the box in the backward direction is

$$F' = F - f = ma - \mu mg = m(a - \mu g) \\ = 40(2 - 0.15 \times 9.8) = 21.2 \text{ N.}$$

Acceleration produced in the box in the backward direction,

$$a' = \frac{F'}{m} = \frac{21.2}{40} = 0.53 \text{ ms}^{-2}$$

If the box takes time  $t$  to fall off the truck, then

$$s = ut + \frac{1}{2} a' t^2 \text{ or } 5 = 0 \times t + \frac{1}{2} \times 0.53 \times t^2$$

or 
$$t^2 = \frac{5 \times 2}{0.53} = \frac{10}{0.53}$$

The distance covered by the truck accelerating at  $2 \text{ ms}^{-2}$  during this time is

$$s' = \frac{1}{2} at^2 = \frac{1}{2} \times 2 \times \frac{10}{0.53} = 18.57 \text{ m.}$$

5.37. A disc revolves with a speed of  $33 \frac{1}{3} \text{ rev min}^{-1}$ , and has a radius of 15 cm. Two coins are placed at 4 cm and 14 cm away from the centre of the disc. If the coefficient of friction between the coins and the disc is 0.15, which of the two coins will revolve with the disc? Take  $g = 9.8 \text{ ms}^{-2}$ .

Ans. Here  $v = 33 \frac{1}{3} \text{ rpm} = \frac{100}{3} \text{ rpm} = \frac{100}{3 \times 60} \text{ rps}$

$$\omega = 2\pi v = 2 \times \frac{22}{7} \times \frac{100}{3} \times \frac{1}{60} = \frac{220}{63} \text{ rad s}^{-1}$$

$$r = 15 \text{ cm, } \mu = 0.15$$

The coin will revolve with the disc if the force of friction is enough to provide the necessary centripetal force,

i.e.  $mr\omega^2 \leq \mu mg \text{ or } r \leq \frac{\mu g}{\omega^2}$

Now 
$$\frac{\mu g}{\omega^2} = \frac{0.15 \times 9.8}{\left(\frac{220}{63}\right)^2} = 0.12 \text{ m} = 12 \text{ cm}$$

Thus the coin placed at a distance of 4 cm from the centre of the disc will revolve with the disc.

5.38. You may have seen in a circus a motorcyclist driving in vertical loops inside a 'death-well' (a hollow spherical chamber with holes, so that the spectators can watch from outside). Explain clearly why the motorcyclist does not drop down when he is at the uppermost point, with no support from below. What is the minimum speed required to perform a vertical loop if the radius of the chamber is 25 m?

Ans. At the highest point of the death-well, the normal reaction  $R$  of the walls of the chamber acts downwards. The centripetal force is provided by his weight  $mg$  and the normal reaction  $R$ .

$$\therefore \frac{mv^2}{r} = R + mg$$

The motorcyclist does not fall down due to the balancing of these forces. For minimum speed, at the highest point,  $R = 0$ , so that

$$\frac{mv_{\min}^2}{r} = mg$$

or 
$$v_{\min} = \sqrt{rg} = \sqrt{25 \times 9.8} = 15.65 \text{ ms}^{-1}.$$

5.39. A 70 kg man stands in contact against the wall of a cylindrical drum of radius 3 m rotating about its vertical axis with 200 rev/min. The coefficient of friction between the wall and his clothing is 0.15. What is the minimum rotational speed of the cylinder to enable the man to remain stuck to the wall (without falling) when the floor is suddenly removed?

Ans. Here  $r = 3 \text{ m, } \mu = 0.15,$

$$v = 200 \text{ rpm} = \frac{200}{60} \text{ rps}$$

$$\omega = 2\pi v = 2 \times \frac{22}{7} \times \frac{200}{60} = \frac{400}{7} \text{ rad s}^{-1}$$

The horizontal reaction  $R$  of the wall on the man provides the necessary centripetal force.

$$R = \frac{mv^2}{r} = mr\omega^2 \quad [\because v = r\omega]$$

The frictional force  $f$  acting vertically upwards balances the weight of the man. The man will remain stuck to the wall after the floor is removed, if

$$f \leq \mu R$$

or  $mg \leq \mu mr\omega^2 \quad [\because f = mg]$

or  $g \leq \mu r\omega^2 \text{ or } \omega^2 \geq \frac{g}{\mu r}$

The minimum rotational speed of the cylinder is

$$\omega_{\min} = \sqrt{\frac{g}{\mu r}} = \sqrt{\frac{9.8}{0.15 \times 3}} = \sqrt{21.78} = 4.7 \text{ rad s}^{-1}.$$

5.40. A thin circular loop of radius  $R$  rotates about its vertical diameter with an angular frequency  $\omega$ . Show that a small bead on the wire remains at its lowermost point for  $\omega \leq \sqrt{\frac{g}{R}}$ . What is the angle made by the radius vector joining

the centre to the bead with the vertical downward direction for  $\omega = \sqrt{\frac{2g}{R}}$ ? Neglect friction.

Ans. Fig. 5.138 shows the free-body diagram of the bead when the radius vector joining the centre to the bead makes an angle  $\theta$  with the vertical downward direction. The normal reaction here is equal to the centrifugal force,

i.e., 
$$N = \frac{mv^2}{R} = m\omega^2 R$$

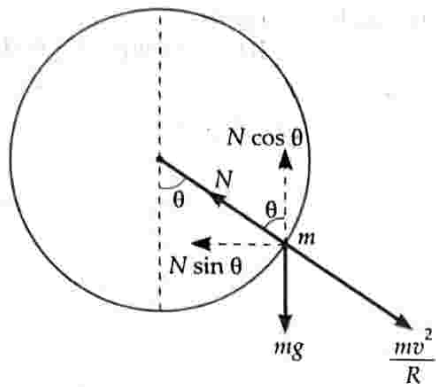

Fig. 5.138

$$\text{Also } mg = N \cos \theta = m\omega^2 R \cos \theta$$

$$\therefore \omega^2 = \frac{g}{R \cos \theta} \quad \text{or} \quad \omega = \sqrt{\frac{g}{R \cos \theta}}$$

For the bead to remain in the lowermost position,  $\theta = 0^\circ$  and  $\cos \theta = 1$ . Hence

$$\omega = \sqrt{\frac{g}{R}}$$

Thus the bead will remain in the lowermost position, if

$$\omega \leq \sqrt{\frac{g}{R}}$$

For  $\omega = \sqrt{\frac{2g}{R}}$ , we have

$$\cos \theta = \frac{g}{\omega^2 R} = \frac{g}{\frac{2g}{R} \cdot R} = \frac{1}{2}$$

$$\therefore \theta = 60^\circ.$$

## Text Based Exercises

### Type A : Very Short Answer Questions

1 Mark Each

- Is any external force required to keep a body in uniform motion ?
- State Aristotelian law of motion. What is flaw in this law ?
- State Galileo's law of inertia.
- Define the term inertia.
- What gives the measure of inertia ?
- Define inertial mass of a body.
- Name the scientist who first gave the laws of motion.
- State Newton's first law of motion.  
[Delhi 03C ; Central Schools 07]
- A piece of cork is floating on water. What is the net force acting on it ?
- How does Newton's first law of motion define force ?
- Which law of motion gives the measure of force ?
- Name the scientist who first introduced the concept of momentum.
- Write the dimensions of momentum.
- What are the SI and CGS units of momentum ?
- What is the ratio of SI to the CGS units of momentum ?
- State Newton's Second law of motion.  
[Delhi 03 ; Central Schools 07]
- Define one newton force. [Delhi 96, Manipur 99]
- Define one dyne.
- Write the relation between newton and dyne.
- Is it correct to say that the second law of motion is the real law of motion ?
- Write the second law of motion in vector form.
- Show that if the force acting on a particle is zero, its momentum will remain unchanged. [BIT Ranchi 97]
- The two ends of a spring balance are pulled each by a force of 10 kg wt. What will be the reading of the spring balance ?
- A person is standing on a weighing machine placed near a door. What would be the effect on the reading of the machine if a person (i) presses the edge of the door upward (ii) pulls downwards ?
- What are the conditions for maximum and minimum pull of a lift on a supporting cable.
- A lift is going up with an acceleration  $2g$ . A man is inside the lift and his mass is  $m$ . What will be the reaction of the floor on the man ?
- Which of Newton's laws of motion is involved in rocket propulsion ?
- A person sitting in the compartment of a train moving with uniform speed throws a ball in the upward direction (i) What path of the ball will appear to him ? (ii) What to a person standing outside ?
- State the principle of conservation of linear momentum. [Kerala 01 ; Delhi 08]
- Will the momentum remain conserved if some external force acts on the system ?

31. What is the principle of working of a rocket ?  
[Delhi 10]
32. Vehicles stop on applying brakes. Does this phenomenon violate the principle of conservation of momentum ?
33. A bomb explodes in mid-air into two equal fragments. What is the relation between the direction of motion of the two fragments ?
34. The total momentum of the universe remains constant. Is this statement true ?
35. Can a rocket operate in free space ?
36. Is impulse a scalar or vector quantity ? Write its SI unit.
37. The dimensional formula of impulse is  $MLT^{-1}$ . Name another physical quantity having the same dimensions.  
[Delhi 96]
38. A bus weighing 900 kg is at rest on the bus stand. What is the linear momentum of the bus ?  
[Himachal 02]
39. What is dry friction ?
40. What is wet friction ?
41. What is normal reaction ?
42. Define limiting friction.  
[Himachal 09]
43. Define coefficient of limiting friction.
44. What is the unit of coefficient of limiting friction.  
[Himachal 01]
45. Which is greater  $\mu_s$  or  $\mu_k$  ?
46. Write the relation between coefficient of friction and angle of friction ?
47. What is the relation between angle of friction and angle of repose ?
48. Is rolling friction more than sliding friction ?
49. On what factors does the coefficient of friction depend ?
50. Which is greatest out of static friction, limiting friction and kinetic friction ?
51. What is the angle between frictional force and instantaneous velocity of a body moving over a rough surface ?
52. A body is just sliding down an inclined plane due to its own weight. What is the relation between angle of inclination and angle of repose ?
53. A body slides down an inclined plane having friction. Indicate the directions of the frictional force and the reaction of the plane on the body.  
[Manipur 99]
54. Give an example of the use of friction.
55. Does the force of friction depend on the area of contact ?
56. What is the angle of friction between two surfaces in contact if the coefficient of friction is  $1/\sqrt{3}$  ?  
[Himachal 07C]
57. Define angle of friction.  
[Himachal 01C ; Central Schools 07]
58. It is easier to roll a barrel than to pull it along the road. Why ?  
[Himachal 07]
59. Why are rockets given conical shape ?
60. Arrange  $\mu_s$ ,  $\mu_k$  and  $\mu_r$  in ascending order.
61. A body is moving along a circular path such that its speed is always constant. Should there be a force acting on the body ?  
[Himachal 02]
62. What provides the centripetal force to a satellite revolving around the earth ?  
[Punjab 91]
63. What furnishes the centripetal force for the electrons to go round the nucleus ?
64. Can a centripetal force produce rotation ?
65. Which is real among the centripetal and centrifugal forces ?
66. What provides the centripetal force to a car taking a turn on a level road ?  
[Himachal 06]
67. Does the angle of banking depend on the mass of the vehicle ?
68. When a body moves in a circular path, which thing experiences a centrifugal force ?
69. A body is travelling with a constant speed on the circumference of a circle. Of the quantities (i) linear velocity (ii) linear acceleration (iii) acceleration towards the centre and (iv) centripetal force, which remains constant ?
70. A circus man starts down an inclined plane on his scooter. At the end of the inclined plane, there is a vertical circular arch. If he is to safely negotiate the arch, what must be his velocity at the end of the plane ?
71. How many newtons make one kg wt. ?  
[Central Schools 04, 12]
72. Define impulse. [Central Schools 05 ; Himachal 09C]
73. What is difference between mN and nm ?  
[Himachal 03]
74. From which Newton's laws of motion, the definition of force comes ?  
[Himachal 03]
75. Give and state the SI unit of force.  
[Himachal 03]
76. What is friction ?  
[Himachal 04, 09]
77. What is the unit of coefficient of limiting friction ?  
[Himachal 01]
78. What happens to coefficient of friction, when weight of body is doubled ?  
[Chandigarh 03]
79. What is the need of banking a circular road ?  
[Himachal 04 ; Delhi 09]
80. Three forces start acting simultaneously on a particle moving with a velocity  $\vec{v}$ . These forces are represented in magnitude and direction by three sides of a triangle taken in the same order. What now will be the velocity of the particle ?  
[AIEEE 03]

81. Action and reaction forces do not balance each other. Why? [Himachal 06 ; Delhi 12]

Or

Action and reaction are equal and opposite. Why cannot they cancel each other? [Central Schools 12]

82. If the net external force acting on a body is zero, then the body at rest continues to remain at rest and a body in motion continues to move with uniform motion. What is the name given to this property of the body? [Delhi 08]
83. A tennis ball of mass ' $m$ ' strikes the massive wall with vel ' $v$ ' and traces the same path. Calculate the change in momentum. [Central Schools 08, 09]
84. What will be the maximum velocity with which a vehicle can negotiate a turn of radius  $r$  safely, when the coefficient of friction between the tyres and the road is  $\mu$ ? [Himachal 07]
85. Athlete runs a certain distance before long jump. Name the law that explains it. [Central Schools 07]

## Answers

- No.
- Aristotelian law of motion states that an external force is required to keep a body in motion. This law is wrong. In practice, a force is required to counter the opposing force of friction.
- A body moving in a straight line with a certain speed will continue moving in the same straight line with the same speed in the absence of any external force.
- Inertia is the inherent property of a material body by virtue of which it cannot change, by itself, its state of rest or of uniform motion in a straight line.
- Mass of a body gives the measure of its inertia.
- Inertial mass of a body is equal to the force required to produce unit acceleration in the body.
- Isaac Newton.
- According to Newton's first law of motion, every body continues in its state of rest or of uniform motion, unless an external force is applied to change that state.
- Zero, because the weight of the piece of cork is balanced by the upthrust of water on it.
- Refer answer to Q. 11 on page 5.4.
- Newton's second law of motion.
- Isaac Newton.
- [ $MLT^{-1}$ ].
- The SI unit of momentum is  $kg\ ms^{-1}$  and CGS unit of momentum is  $g\ cms^{-1}$ .
- $10^5$ .
- Newton's second law of motion states that the rate of change of momentum of a body is directly proportional to the applied force and the change in momentum takes place in the direction of the applied force.
- One newton is defined as the force which produces an acceleration of  $1\ ms^{-2}$  in a body of mass 1 kg.
- One dyne is defined as the force which produces an acceleration of  $1\ cms^{-2}$  in a body of mass 1 gram.
- $1\ newton = 10^5\ dyne$ .
- Yes, because both the first and third law of motions are contained in the second law of motion.
- $\vec{F} = m\vec{a}$ .
- According to Newton's second law,
 
$$\vec{F} = \frac{d\vec{p}}{dt}$$
 As  $\vec{F} = 0 \therefore \frac{d\vec{p}}{dt} = 0$ 
 or  $\vec{p} = \text{constant}$ .
- The reading of the spring balance will be 10 kg wt.
- (i) The reading in the weighing machine will increase.  
(ii) The reading in the weighing machine will decrease.
- When the lift is falling freely, the pull of the cable is minimum (zero). When the lift is moving up with some acceleration, then the pull is maximum.
- Let  $R$  be the reaction, then
 
$$R - mg = 2\ mg \therefore R = 3\ mg.$$
- Newton's third law of motion.
- (i) Vertically downwards.  
(ii) Parabolic to the person standing outside.
- If no external force acts on a system, the momentum of the system remains constant.
- No, it is true only for an isolated system.
- Law of conservation of linear momentum.
- No, it does not violate the law of conservation of momentum because an external force is acting on the system.
- The two fragments will fly off in exactly opposite directions.
- Yes. As no external force can be applied on the universe, so its total momentum remains constant.
- Yes.
- Impulse is a vector quantity. Its SI unit is  $Ns$ .
- Linear momentum has same dimensions as the impulse.

38. Zero.
39. The force of friction between solid surfaces in contact is called dry friction.
40. The force of friction between a solid surface and a liquid surface is called wet friction.
41. It is the force of reaction on a body due to the surface on which it is placed. It acts perpendicular to the surface of contact.
42. The maximum force of static friction which comes into play when a body just starts moving over the surface of another body is called limiting friction.
43. The coefficient of limiting friction is defined as the ratio of limiting friction to the normal reaction.
44. The coefficient of limiting friction has no units.
45.  $\mu_s > \mu_k$ .
46. Coefficient of friction = Tangent of the angle of friction or  $\mu = \tan \theta$ .
47. Angle of friction = Angle of repose.
48. No, rolling friction is less than sliding friction.
49. The coefficient of friction depends on  
(i) nature of the surfaces in contact and  
(ii) nature of motion.
50. Limiting friction is greatest.
51. As the force of friction always opposes the relative motion, so the angle is  $180^\circ$ .
52. Angle of inclination = Angle of repose.
53. See Fig. 5.81 on page 5.45.
54. The friction between our feet and the ground helps us to move forward.
55. No, force of friction does not depend on the area of contact.
56.  $\mu = \tan \theta = 1/\sqrt{3} \therefore \theta = 30^\circ$ .
57. Angle of friction is the angle which the resultant of limiting friction and the normal reaction makes with the normal reaction.
58. This is because rolling friction is less than the sliding friction.
59. Conical shape of the rockets reduces atmospheric friction.
60.  $\mu_r < \mu_k < \mu_s$ .
61. Yes, a centripetal force must be acting on the body.
62. Gravitational force of attraction on the satellite due to the earth.
63. The electrostatic attraction on the electrons due to the nucleus.
64. No. A centripetal force can move a body along a circular path but cannot produce rotational motion.
65. Centripetal force.
66. The force of friction between the tyres and the road provides the necessary centripetal force to the car for taking a turn on a level road.
67. No, the angle of banking does not depend on the mass of the vehicle.
68. The agency forcing the body to move in a circular path experiences the centrifugal force.
69. No quantity remains constant because the directions of all these vectors change from instant to instant. However, the magnitudes of all these quantities remain constant.
70.  $v = \sqrt{5gr}$ , where  $r$  is the radius of the circular arch.
71. 1 kg wt = 9.8 N.
72. Impulse is the total effect of a large force which acts for a short time to produce a finite change in momentum.  

$$\text{Impulse} = \text{Force} \times \text{its time duration}$$

$$= \text{Total change in momentum.}$$
73. 1 mN = 1 millinewton =  $10^{-3}$  N  
1 nm = 1 nanometre =  $10^{-9}$  m
74. First law of motion.
75. The SI unit of force is newton. One newton is the force which produces an acceleration of  $1 \text{ ms}^{-2}$  in a body of mass 1 kg.
76. Friction is the opposing force which comes into play between the surfaces in contact, when one body moves or tends to move over the surface of another body.
77. The coefficient of limiting friction is the ratio of two forces, so it has no unit.
78. The coefficient of friction remains unchanged.
79. When the circular road is banked, the horizontal component of the normal reaction of the road provides the necessary centripetal force for the vehicle to move it along the curved path.
80. The resultant of the three forces is zero. The velocity  $\vec{v}$  of the particle will remain unaffected.
81. As the action and reaction forces act on different bodies, they cannot cancel each other.
82. Inertia.
83. Change in momentum =  $m(-v) - mv = -2mv$ .
84. The maximum safe velocity,  $v = \sqrt{\mu rg}$ .
85. Law of inertia.

## Type B : Short Answer Questions

2 or 3 Marks Each

1. What is inertia ? Discuss its types giving one example in each case.
2. Define momentum. Is it a scalar or vector quantity ? Give its units and dimensions.

3. State Newton's second law of motion. Hence, derive the relation  $\vec{F} = m\vec{a}$ , where the symbols have their usual meanings. [Himachal 09C ; Delhi 96]
4. State Newton's second law of motion. Show that it gives a measure of force. Hence define 1 N force. [Himachal 04, 05C, 07C]
5. Show that Newton's second law of motion is the real law of motion. [Delhi 98 ; Chandigarh 03 ; Himachal 07C, 08, 09]
6. State the Newton's second law of motion and deduce the Newton's first law from it. [Delhi 09]
7. How can you show that Newton's third law of motion follows from the Newton's second law of motion ?
8. What is force ? What are its absolute and gravitational units ? How are these related to each other ? [Himachal 03, 09]
9. State Newton's Second law of motion. Derive a mathematical formula to calculate force if mass remains constant. Prove that it contains Newton's first law. [Central Schools 03]
10. State Newton's third law of motion. Derive the law of conservation of linear momentum from it. [Manipur 97 ; Himachal 03, 05, 07C]
11. (i) State principle of conservation of momentum.  
(ii) A bullet of mass ' $m$ ' is fired from a gun of mass ' $M$ ' with a horizontal velocity ' $V$ '. Calculate the recoil velocity ' $v$ ' of the gun. [Delhi 97]
12. State the principle of conservation of linear momentum. Explain, why the gun recoils when a bullet is fired from it. [Himachal 02, 07C]
13. Derive the law of conservation of momentum from Newton's second law of motion.
14. Derive Newton's third law of motion from the law of conservation of momentum.
15. State law of conservation of momentum and prove it by using third law of motion. [Chandigarh 02 ; Himachal 09C]
16. Name a varying mass system. Derive an expression for velocity of propulsion of a rocket at any instant. [Chandigarh 03]
17. Two masses  $M$  and  $m$  are connected at the two ends of an inextensible string. The string passes over a smooth frictionless pulley. Obtain the acceleration of the masses and the tension in the string. Given  $M > m$ . [Delhi 12 ; Central Schools 12]
18. Define the terms momentum and impulse. State and prove impulse-momentum theorem. [Himachal 06, 09C]
19. Define the term impulse, Give its SI unit. Prove that impulse of a force is equal to the change in momentum. [Himachal 06, 07C, 08]
20. What are concurrent forces ? Obtain a condition for the equilibrium of three concurrent forces. [Himachal 06, 09C]
21. What do you mean by equilibrium of concurrent forces. Prove that under the action of three concurrent forces  $\vec{F}_1$ ,  $\vec{F}_2$  and  $\vec{F}_3$ , a body will be in equilibrium, when  $\vec{F}_1 + \vec{F}_2 + \vec{F}_3 = 0$ . [Himachal 01, 05C]
22. What are inertial and non-inertial frames of reference ? Give an example of each.
23. What is friction ? Explain the cause of sliding friction. [Himachal 08]
24. What is limiting friction ? State the laws of limiting friction. [Himachal 07 ; Central Schools 12]
25. State the laws of kinetic friction. Define coefficient of kinetic friction.
26. Define angle of friction. Show that the tangent of the angle of friction is equal to the coefficient of static friction.
27. Define coefficient of friction and angle of friction and hence derive a relation between them. [Chandigarh 08]
28. Define angle of repose. Deduce its relation with coefficient of static friction. [Himachal 04, 07]
29. Explain why it is easier to pull a lawn roller than to push it ? [Central Schools 05]
30. Define limiting friction. Prove that it is always convenient to pull a heavier body than to push it, on the surface. [Chandigarh 07]
31. Friction is a necessary evil. Explain. [Himachal 05, 06, 09C]
32. Describe any three methods of reducing friction. [Kerala 01 ; Himachal 04, 08]
33. Define force of friction. How does the use of ball bearing reduce friction ? [Delhi 05]
34. Distinguish between static friction, limiting friction and kinetic friction. How do they vary with the applied force, explain by diagram. [Chandigarh 04]
35. Find an expression for the work done in sliding a body over a rough horizontal surface.
36. Derive an expression for the work done when a body is made to slide up a rough inclined plane.
37. Derive an expression for the work done when a body slides down a rough inclined plane.
38. Obtain an expression for the acceleration of a body sliding down a rough inclined plane.
39. State two advantages of friction in daily life. [Delhi 96]
40. Define the term coefficient of limiting friction between the surfaces. A body of mass 10 kg is placed on an inclined surface of angle  $30^\circ$ . If the coefficient of limiting friction is  $1/\sqrt{3}$ , find the force



- required to just push the body up the inclined plane. The force is being applied parallel to the inclined surface. [Delhi 02]
41. When a horse pulls a cart, according to Newton's third law, the cart also pulls the horse with an equal and opposite force. What causes the motion of the horse, cart and the system as a whole? Explain with a diagram. [Central Schools 08]
42. Why does a cyclist lean inwards while negotiating a curve? Explain with a diagram. [Delhi 99, 02; Himachal 02, 09C]
43. Obtain an expression for the angle which a cyclist will have to make with the vertical, while taking a circular turn. [For successful negotiation]. [Chandigarh 07]
44. Find an expression for the maximum speed of circular motion of a car in a circular horizontal track of radius 'R'. The coefficient of static friction between the car tyres and the road along the surfaces is  $\mu_s$ . [Delhi 03]
45. Draw the free body diagram of a car on a banked road. [Central Schools 03]
46. With the help of suitable diagram, obtain an expression for the maximum speed with which a vehicle can safely negotiate a curved road banked at an angle  $\theta$ . The coefficient of friction between the wheels and road is  $\mu$ . [Delhi 06; Central Schools 12]
47. Derive a relation for the optimum velocity of negotiating a curve by a body in a banked curve. [Central Schools 04]
48. State Newton's second and third laws of motion. Explain how these laws lead to an important consequence – the law of conservation of angular momentum. [Delhi 03C]
49. A block of wood of mass  $m$  rests on a rough horizontal plane. The plane is gradually inclined at an angle  $\theta$  with the horizontal until the block just begins to slide. Find the coefficient of static friction between the block and the plane. [Delhi 03C]
50. A small body tied to one end of the string is whirled in a vertical circle.
- (i) Represent the forces on a diagram when the string makes an angle  $\theta$  with initial position.
- (ii) Find the tension and velocity at the highest and lowest point respectively. [Delhi 05]
51. What do you mean by ball bearings? How sliding friction is converted into rolling friction? [Himachal 09]

## Answers

- Refer answer to Q. 4 on page 5.2.
- Refer answer to Q. 7 on page 5.3.
- Refer answer to Q. 16 on page 5.5.
- Refer answer to Q. 16 on page 5.5.
- Refer answer to Q. 36 on page 5.17.
- Refer answer to Q.36 on page 5.17.
- Refer answer to Q.36 on page 5.17.
- Refer answer to Q. 18 on page 5.6.
- Refer answer to Q. 16 on page 5.5 and Q. 36 on page 5.17.
- Refer answer to Q. 39 on page 5.20.
- (i) Refer answer to Q. 38 on page 5.20.  
(ii) Refer answer to Q. 41 on page 5.21.
- Refer answer to Q. 38 on page 5.20 and Q. 41 on page 5.21.
- Refer answer to Q. 38 on page 5.20.
- Refer answer to Q. 40 on page 5.20.
- Refer answer to Q. 39 on page 5.20.
- Refer answer to Q. 42 on page 5.24.
- Refer answer to Q. 45 on page 5.31.
- Refer answer to Q.28 on page 5.11.
- Refer answer to Q. 28 on page 5.11.
- Refer answer to Q.43 on page 5.27.
- Refer answer to Q. 43 on page 5.27.
- Refer answer to Q. 71 on page 5.62.
- Refer answer to Q. 47 on page 5.37 and Q. 49 on page 5.37.
- Refer answer to Q. 51 on page 5.38.
- Refer answer to Q. 52 on page 5.38.
- Refer answer to Q. 53 on page 5.39.
- Refer answer to Q.53 on page 5.39.
- Refer answer to Q. 54 on page 5.39.
- Refer answer to Q. 65 on page 5.51.
- Refer answer to Q.65 on page 5.51.
- Refer answer to Q. 62 on page 5.51.
- Refer answer to Q. 63 on page 5.51.
- Refer answer to Q. 63 on page 5.51.
- Refer answer to Q. 50 on page 5.37.
- Refer answer to Q. 58 on page 5.44.
- Refer answer to Q. 59 on page 5.45.
- Refer answer to Q. 60 on page 5.45.
- Refer answer to Q. 61 on page 5.45.
- Refer answer to Q. 62 on page 5.51.
- The coefficient of limiting friction is defined as the ratio of limiting friction to the normal reaction.

$$F = mg (\sin \theta + \mu \cos \theta)$$

$$= 10 \times 9.8 \left( \sin 30^\circ + \frac{1}{\sqrt{3}} \cos 30^\circ \right) = 98 \left( \frac{1}{2} + \frac{1}{\sqrt{3}} \cdot \frac{\sqrt{3}}{2} \right)$$

$$= 98 \text{ N.}$$

41. Refer answer to Q. 35 on page 5.16.  
 42. Refer answer to Q. 69 on page 5.55.  
 43. Refer answer to Q.60 on page 5.45.  
 44. Refer answer to Q. 68 on page 5.54.  
 45. See Fig. 5.101 on page 5.54.  
 46. Refer answer to Q. 68 on page 5.54.  
 47. Refer answer to Q. 68 on page 5.54.  
 48. Refer answer to Q. 38 on page 5.20 and Q. 5.39 on page 5.20.  
 49. Refer answer to Q. 54 on page 5.39.  
 50. Refer answer to Q. 70 on page 5.58.  
 51. Refer answer to Q. 63 (iv) page 5.51.

### Type C : Long Answer Questions

5 Marks Each

- Prove that the velocity of a rocket at any instant when its mass is  $m$  is given by  $v = v_0 + u \log_e \frac{m_0}{m}$   
 where,  $v_0$  and  $m_0$  are the velocity and mass of the rocket at  $t = 0$  and  $u$  is the velocity of exhaust gases relative to the rocket. [Himachal 02 ; Delhi 06]
- (a) A person of mass  $m$  is standing in a lift. Find his apparent weight when the lift is : (i) moving upward with uniform acceleration  $a$ . (ii) moving downward with uniform acceleration  $a (< g)$ . (iii) falls freely.  
 (b) Explain why, it is easier to pull a lawn mover than to push it. [Delhi 12]
- (a) Obtain an expression for the centripetal force required to make a body of mass  $m$ , moving with a velocity  $v$  around a circular path of radius  $r$ .  
 (b) Find an expression for velocity of recoil of gun. [Chandigarh 07]
- Define the terms static friction, limiting friction and kinetic friction. Draw the graph between friction and applied force on any object and show static friction, limiting friction and kinetic friction in graph.  
 Using graph show that static friction is a self-adjusting force. [Delhi 12]
- What do you understand by friction ? Discuss about static friction, limiting friction, kinetic friction and rolling friction. Show how the force of friction varies with the applied friction  $F$ . [Delhi 08, 10]
- Define angle of friction and angle of repose. Show that both are numerically equal. [Himachal 02, 03]
- Explain the terms : friction and limiting friction. State the laws of limiting friction. Give some methods for reducing friction. [Himachal 02]
- What is meant by banking of roads ? What is the need for banking a road ? Obtain an expression for the maximum speed with which a vehicle can safely negotiate a curved road banked at an angle  $\theta$ . The coefficient of friction between the wheels and the road is  $\mu$ . [Delhi 08, 10]
- Derive an expression for velocity of a car on a banked circular road having coefficient of friction  $\mu$ . Hence write the expression for optimum velocity. [Chandigarh 08]
- (a) Why are circular roads banked ? Deduce an expression for the angle of banking.  
 (b) A 1000 kg car rounds a curve on a flat road of radius 50 m at a speed of  $50 \text{ km h}^{-1}$  ( $14 \text{ ms}^{-1}$ ). Will the car make the turn or will it skid if the coefficient of friction is 0.60 ? Justify. [BIT Ranchi 99]
- What are centripetal and centrifugal forces ? A body attached to a string of length  $l$  describes a vertical circle such that it is just able to cross the highest point. Find the minimum velocity at the bottom of the circle. [Meghalaya 99]

### Answers

- Refer answer to Q. 42 on page 5.24.
- (a) Refer answer to Q. 37 on page 5.17.  
 (b) Refer answer to Exercise 5.23(c) on page 5.79.
- (a) Refer answer to Q. 66 on page 5.52.  
 (b) Refer to answer to Q.41(i) on page 5.21.
- Refer answer to Q. 50 on page 5.37.
- Refer answer to Q. 50 on page 5.37.
- Refer answer to Q. 53 and Q. 54 on page 5.39.
- Refer answer to Q. 51 on page 5.38 and Q. 63 on page 5.51.
- Refer answer to Q.68 on page 5.54.
- Refer answer to Q.68 on page 5.54.
- (a) Refer answer to Q. 68 on page 5.54.  
 (b) Required centripetal force  

$$= \frac{mv^2}{r} = \frac{1000 \times (14)^2}{50} = 3920 \text{ N}$$
 Force of friction  

$$= \mu mg = 0.60 \times 1000 \times 9.8 = 5880 \text{ N}$$
 As the available force of friction is greater than the required centripetal force, so the car will not skid.
- Refer answer to Q. 70 on page 5.58.

## Laws of Motion

### GLIMPSES

- Force.** It may be defined as an agency (a push or pull) which changes or tends to change the state of rest or of uniform motion or the direction of motion of a body. Force is a vector quantity.
- Inertia.** It is the inherent property of a material body by virtue of which it cannot change, by itself, its state of rest or of uniform motion in a straight line. Inertia is of *three* types (i) inertia of rest (ii) inertia of motion and (iii) inertia of direction.
- Mass as the measure of inertia.** If a body has more mass, it has more inertia *i.e.*, it is more difficult to change its state of rest or of uniform motion.
- Momentum.** It is the quantity of motion in a body. It is equal to the product of mass  $m$  and velocity  $v$  of the body.

$$\text{Momentum, } p = mv \text{ or } \vec{p} = m\vec{v}$$

Momentum is a vector quantity having the direction of velocity  $\vec{v}$ . Its SI unit is  $\text{kg ms}^{-1}$  and CGS unit is  $\text{g cms}^{-1}$ .

- Newton's first law of motion.** It states that every body continues in its state of rest or of uniform motion along a straight line, unless an external force is applied to change that state. This law defines force.
- Newton's second law of motion.** It states that the rate of change of momentum of a body is directly proportional to the applied force and the change in momentum takes place in the direction of the applied force. This law gives a measure of the force.

Mathematically,

$$F = \frac{dp}{dt} = \frac{d}{dt}(mv) = m \frac{dv}{dt} = ma = m \left( \frac{v - u}{t} \right)$$

- When  $m$  is constant and  $v$  changes,

$$F = m \frac{dv}{dt}$$

- When  $v$  is constant and  $m$  changes,

$$F = v \frac{dm}{dt}$$

In component form, Newton's second law may be expressed as

$$F_x = \frac{dp_x}{dt} ; F_y = \frac{dp_y}{dt} ; F_z = \frac{dp_z}{dt}$$

- Newton's third law of motion.** It states that to every action, there is an equal and opposite reaction. Mathematically,

$$\vec{F}_{BA} = -\vec{F}_{AB}$$

Forces of action and reaction never cancel out because they act on different bodies.

- Absolute units of force.** The SI unit of force is *newton* (N) and CGS unit is *dynes* (dyn).

$$1 \text{ newton (N)} = 1 \text{ kg} \times 1 \text{ ms}^{-2} = 1 \text{ kg ms}^{-2}$$

$$1 \text{ dyne (dyn)} = 1 \text{ g} \times 1 \text{ cms}^{-2} = 1 \text{ g cms}^{-2}$$

$$1 \text{ N} = 10^5 \text{ dyn}$$

- Gravitational units of force.** The SI unit of force is *kilogram weight* (kg wt) or *kilogram force* (kg f) and the CGS unit is *gram weight* (g wt) or *gram force* (g f).

$$1 \text{ kg wt} = 1 \text{ kg f} = 1 \text{ kg} \times 9.8 \text{ ms}^{-2} = 9.8 \text{ N}$$

$$1 \text{ g wt} = 1 \text{ g f} = 1 \text{ g} \times 980 \text{ cms}^{-2} = 980 \text{ dyn}$$

- Impulse of a force.** Impulse is the total effect of a large force which acts for a short time to produce a finite change in momentum. It is defined as the product of the force and the time for which it acts and equal to the total change in momentum.

$$\text{Impulse} = \text{Force} \times \text{time duration}$$

$$= \text{Total change in momentum.}$$

Impulse is a vector quantity, denoted by  $\vec{J}$ .

$$\vec{J} = \int_{t_1}^{t_2} \vec{F} \cdot dt$$

= Area under the force-time ( $F-t$ ) graph.

or  $\vec{J} = \vec{F}_{av} \times t = \vec{p}_2 - \vec{p}_1 = m(\vec{v} - \vec{u})$

The SI unit of impulse is Ns or  $\text{kg ms}^{-1}$  and CGS unit is dyn s or  $\text{g cms}^{-1}$ .

**11. Apparent weight of body in a lift.**

(i) When a lift moves upwards with uniform acceleration  $a$ , apparent weight of a body in the lift increases.

From Fig. (a),

$$R - mg = ma \quad \text{or} \quad R = m(g + a)$$

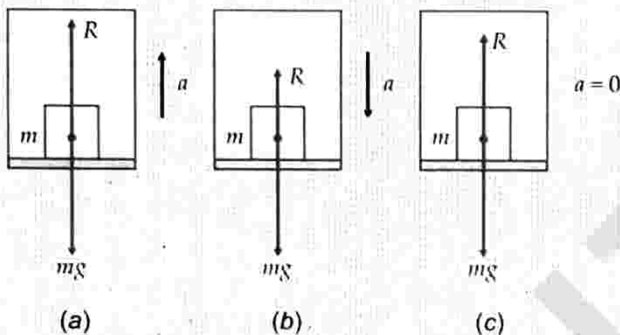

(ii) When a lift moves downwards with acceleration  $a$ , the apparent weight of a body in the lift decreases. From Fig. (b),

$$mg - R = ma \quad \text{or} \quad R = m(g - a)$$

(iii) When a lift is at rest or moves with uniform velocity,  $a = 0$ , the apparent weight of the body is equal to its true weight.

From Fig. (c),

$$R = mg$$

(iv) When a lift falls freely, ( $a = g$ ) the apparent weight of a body in the lift becomes zero.

$$R = m(g - g) = 0.$$

**12. Law of conservation of linear momentum.**

(i) In the absence of any external force, vector sum of the linear momenta of a system of particles remains constant.

$$\vec{p} = \vec{p}_1 + \vec{p}_2 + \vec{p}_3 + \dots + \vec{p}_n = \text{constant}$$

or  $m_1 \vec{v}_1 + m_2 \vec{v}_2 + m_3 \vec{v}_3 + \dots + m_n \vec{v}_n = \text{constant}$

(ii) When two bodies collide,

Total momentum before collision  
= Total momentum after collision

$$m_1 u_1 + m_2 u_2 = m_1 v_1 + m_2 v_2$$

(iii) When a bullet of mass  $m$  is fired with velocity  $v$  from a gun of mass  $M$ , the gun recoils with velocity  $V$ .

Momentum of gun = - Momentum of bullet

$$MV = -mv$$

Recoil velocity of gun,

$$V = -\frac{mv}{M}$$

**13. Rocket propulsion.** It is an example of momentum conservation in which the large backward momentum of the ejected gases imparts an equal forward momentum to the rocket. Due to the decrease in mass of the rocket-fuel system, the acceleration of the rocket keeps on increasing. Let

$u$  = velocity of exhaust gases

$v_0, v$  = initial velocity and velocity of the rocket at any instant  $t$

$m_0, m, m_c$  = initial mass, mass of the rocket at any instant  $t$  and mass of empty rocket.

$\frac{dm}{dt}$  = rate of ejection of fuel.

Thrust on rocket :  $F = -u \frac{dm}{dt}$

Acceleration of rocket :  $a = \left[ \frac{u}{m_0 - t \frac{dm}{dt}} \right] \frac{dm}{dt}$

Velocity of rocket :  $v = v_0 + u \log_c \frac{m_0}{m}$

Burnt-out speed of rocket :  $v_b = v_0 + u \log_c \frac{m_0}{m_c}$

**14. Concurrent forces.** The forces acting at the same point of a body are called concurrent forces.

**15. Equilibrium of concurrent forces.** A number of concurrent forces acting on a body are said to be in equilibrium if their vector sum is zero or if these forces can be completely represented by the sides of a closed polygon taken in the same order.

$$\vec{F}_1 + \vec{F}_2 + \vec{F}_3 + \dots + \vec{F}_n = 0$$

**16. Lami's theorem.** It states that if three forces acting on a particle keep it in equilibrium, then each force is proportional to the sine of the angle between other two forces. If  $\alpha, \beta, \gamma$  be the angles between  $\vec{F}_2$  and  $\vec{F}_3$ ;  $\vec{F}_3$  and  $\vec{F}_1$ ;  $\vec{F}_1$  and  $\vec{F}_2$  respectively, then according to Lami's theorem :

$$\frac{F_1}{\sin \alpha} = \frac{F_2}{\sin \beta} = \frac{F_3}{\sin \gamma}$$

**17. Free-body diagram.** A diagram for each body of the system showing all the forces exerted on the body by the remaining parts of the system is called free-body diagram.

18. **Motion of connected bodies.** Suppose two bodies of masses  $M$  and  $m$  ( $M > m$ ) are tied at the ends of an inextensible string passing over a frictionless pulley. Then

$$\text{Acceleration of the masses, } a = \frac{M - m}{M + m} \cdot g$$

$$\text{Tension in the string, } T = \frac{2Mm}{M + m} \cdot g$$

Clearly,  $a < g$ .

19. **Friction.** Whenever a body moves or tends to move over the surface of another body, a force comes into play which acts parallel to the surface of contact and opposes the relative motion. This opposing force is called friction.
20. **Static friction.** The force of friction which comes into play between two bodies before one body actually starts moving over the other is called static friction ( $f_s$ ). Static friction is a self-adjusting force.
21. **Limiting friction.** The maximum force of static friction which comes into play when a body just starts moving over the surface of another body is called limiting friction ( $f_s^{\text{max}}$ ).
22. **Kinetic friction.** The force of friction which comes into play when a body is in a steady motion over the surface of another body is called kinetic or dynamic friction ( $f_k$ ). Kinetic friction is less than limiting friction.
23. **Laws of limiting friction :**
- The force of limiting friction depends upon the nature of the two surfaces in contact and their state of roughness.
  - The force of limiting friction acts tangential to the two surfaces in contact and in a direction opposite to that of the applied force.
  - The force of limiting friction between any two surfaces is independent of the shape or area of the surfaces in contact so long as the normal reaction remains the same.
  - The force of limiting friction between two given surfaces is directly proportional to the normal reaction between the two surfaces.
- $$f \propto R \quad \text{or} \quad f = \mu_s R$$
- where the constant of proportionality  $\mu_s$  is called the coefficient of limiting friction.
24. **Coefficient of limiting friction.** It is the ratio of limiting friction to the normal reaction.
- $$\mu_s = \frac{f^{\text{max}}}{R} = \frac{\text{Limiting friction}}{\text{Normal reaction}}$$
25. **Coefficient of kinetic friction.** It is the ratio of kinetic friction ( $f_k$ ) to the normal reaction.

$$\mu_k = \frac{f_k}{R} = \frac{\text{Kinetic friction}}{\text{Normal reaction}}$$

$$\text{As } f_k < f_s^{\text{max}} \quad \text{or} \quad \mu_k R < \mu_s R \quad \therefore \mu_k < \mu_s$$

26. **Angle of friction.** It is the angle which the resultant of the limiting friction and the normal reaction makes with the normal reaction. If  $\theta$  is the angle of friction, then  $\tan \theta = \mu_s$ .
27. **Angle of repose.** It is the minimum angle that an inclined plane makes with the horizontal when a body placed on it just begins to slide down. If  $\phi$  is the angle of repose, then  $\tan \phi = \mu_s$ .
28. **Motion along a rough horizontal surface.** If a body of mass  $m$  is moved over a rough horizontal surface through distance  $s$ , then
- Force of friction,  $f = \mu R = \mu mg$
- Retardation produced,  $a = \frac{f}{m} = \mu g$
- Work done against friction,  $W = f \times s = \mu mg s$
- Power =  $f \times v = \mu mg v$ .
29. **Motion along a rough inclined plane.**
- When a body moves down an inclined plane with uniform velocity ( $a = 0$ ), net downward force needed is
 
$$F = mg \sin \theta - f = mg (\sin \theta - \mu \cos \theta)$$
 Work done,  $W = F_s = mg (\sin \theta - \mu \cos \theta) s$
  - When a body moves up an inclined plane with uniform velocity ( $a = 0$ ), net upward force needed is
 
$$F = mg \sin \theta + f = mg (\sin \theta + \mu \cos \theta)$$

$$W = Fs = mg (\sin \theta + \mu \cos \theta) s$$
  - When a body moves up an inclined plane with acceleration  $a$ , net upward force needed is
 
$$F = ma + mg \sin \theta + f$$

$$= m(a + g \sin \theta + \mu g \cos \theta)$$

$$W = m(a + g \sin \theta + \mu g \cos \theta) s$$
30. **Acceleration of body sliding down a rough inclined plane.** When the angle of inclination is greater than the angle of repose, the acceleration produced is
- $$a = g (\sin \theta - \mu_k \cos \theta)$$
31. **Centripetal force.** It is the force required to make a body move along a circular path with a uniform speed. It always acts along the radius and towards the centre of the circular path. The centripetal force required to move a body of mass  $m$  along a circular path of radius  $r$  with speed  $v$  is given by

$$F = \frac{mv^2}{r} = m r \omega^2 = m r (2\pi v)^2 = m r \left(\frac{2\pi}{T}\right)^2$$

32. **Centrifugal force.** It is a fictitious force acting radially outwards on a particle moving in a circle and is equal in magnitude to the centripetal force.
33. **A vehicle taking circular turn on a level road.** If  $\mu$  is the coefficient of friction between tyres and road, then the maximum velocity with which the vehicle can safely take a circular turn of radius  $r$  is given by

$$v = \sqrt{\mu r g}$$

34. **Banking of tracks (roads).** The maximum angle with which a vehicle (in the absence of friction) can negotiate a circular turn of radius  $r$  and banked at an angle  $\theta$  is given by

$$v = \sqrt{r g \tan \theta}$$

When the frictional forces are also taken into account, the maximum safe velocity is given by

$$v = \sqrt{r g \left( \frac{\mu + \tan \theta}{1 - \mu \tan \theta} \right)}$$

35. **Bending of a cyclist.** In order to take a circular turn of radius  $r$  with speed  $v$ , the cyclist should bend himself through an angle  $\theta$  from the vertical such that

$$\tan \theta = \frac{v^2}{r g}$$

36. **Motion in a vertical circle.** As shown in the figure, consider a body of mass  $m$  tied at the end of a string and rotating in a vertical circle of radius  $r$ .

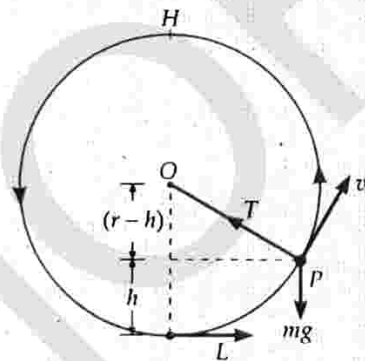

Then

- (i) Velocity at any point  $P$  at a height  $h$  from the lowest point  $L$ ,

$$v = \sqrt{u^2 - 2gh}$$

- (ii) Tension in the string at any point  $P$ ,

$$T = \frac{m}{r} (u^2 - 3gh + gr)$$

- (iii) Tension at the lowest point ( $h = 0$ ),

$$T_L = \frac{m}{r} (u^2 + gr)$$

- (iv) Tension at the highest point  $H$  ( $h = 2r$ ),

$$T_H = \frac{m}{r} (u^2 - 5gr)$$

- (v) Difference in tensions at the highest and lowest points,

$$T_L - T_H = 6mg$$

- (vi) Minimum velocity at the lowest point  $L$  for looping the loop,

$$v_L = \sqrt{5gr}$$

- (vii) Velocity at the highest point for looping the loop,

$$v_H = \sqrt{gr}$$

37. **Inertial frame of reference.** An inertial frame of reference is one in which Newton's first law of motion holds good. All frames moving with uniform motion relative to an inertial frame are also inertial.

38. **Non-inertial frame of reference.** A frame of reference which is accelerating with respect to an inertial frame of reference is called a non-inertial frame of reference. In a non-inertial frame, the second law of motion  $\vec{F} = m\vec{a}$  is not valid.

Instead, it takes the form

$$\vec{F} - m\vec{\alpha} = m\vec{a} \quad \text{or} \quad \vec{F} + \vec{F}_p = m\vec{a}$$

where  $\vec{\alpha}$  is the acceleration of the non-inertial frame relative to any inertial frame and  $\vec{a}$  is the acceleration of the body relative to the non-inertial frame. The force  $\vec{F}_p = -m\vec{\alpha}$  is an example of pseudo force.

### IIT Entrance Exam

**MULTIPLE CHOICE QUESTIONS WITH ONE CORRECT ANSWER**

1. A ship of mass  $3 \times 10^7$  kg initially at rest is pulled by a force of  $5 \times 10^4$  N through a distance of 3 m.

Assuming that the resistance due to water is negligible, the speed of the ship is

- (a) 1.5 m/s                      (b) 60 m/s  
(c) 0.1 m/s                      (d) 5 m/s

2. A vessel containing water is given a constant acceleration  $a$  towards the right, along a straight horizontal path. Which of the following figures represents the surface of the liquid? [IIT 80]

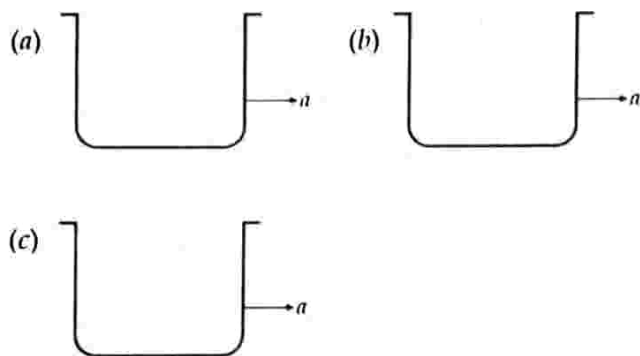

3. Two particles of masses  $m_1$  and  $m_2$  in projectile motion have velocities  $\vec{v}_1 < \vec{v}_2$  respectively at time  $t = 0$ . They collide at time  $t_0$ . Their velocities become  $\vec{v}'_1$  and  $\vec{v}'_2$  at time  $2t_0$ , while still moving in air. The value of  $|(m_1 \vec{v}'_1 + m_2 \vec{v}'_2) - (m_1 \vec{v}_1 + m_2 \vec{v}_2)|$  is

- (a)  $(m_1 + m_2)gt_0$  (b)  $2(m_1 + m_2)gt_0$   
 (c)  $\frac{1}{2}(m_1 + m_2)gt_0$  (d) zero [IIT 01]

4. Two blocks A and B of masses  $2m$  and  $m$  respectively are connected by a massless and inextensible string. The whole system is suspended by a massless spring as shown in the figure. The magnitudes of acceleration of A and B immediately after the string is cut, are respectively

- (a)  $g, g/2$  (b)  $g/2, g$   
 (c)  $g, g$  (d)  $g/2, g/2$  [IIT 06]

5. A string of negligible mass going over a clamped pulley of mass  $m$  supports a block of mass  $M$  as shown in the figure. The force on the pulley by the clamp is given by

- (a)  $\sqrt{2}Mg$   
 (b)  $\sqrt{2}mg$   
 (c)  $\sqrt{(M+m)^2 + m^2}g$   
 (d)  $\sqrt{(M+m)^2 + M^2}g$  [IIT 01]

6. The pulleys and strings shown in the figure are smooth and of negligible mass. For the system to remain in equilibrium, the angle  $\theta$  should be

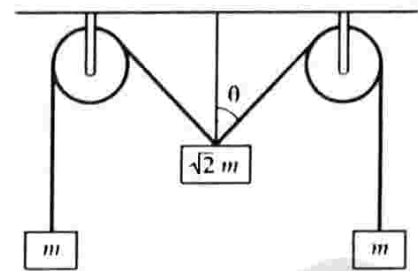

- (a)  $0^\circ$  (b)  $30^\circ$   
 (c)  $45^\circ$  (d)  $60^\circ$  [IIT 01]

7. In the arrangement, shown in the figure, the ends P and Q of an unstretchable string move downwards with uniform speed  $u$ . Pulleys A and B are fixed. Mass M moves upwards with a speed

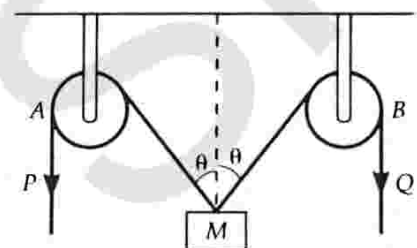

- (a)  $2u \cos \theta$  (b)  $u / \cos \theta$   
 (c)  $2u / \cos \theta$  (d)  $u \cos \theta$  [IIT 82]

8. A particle moves in the X-Y plane under the influence of a force such that its linear momentum is  $\vec{p}(t) = A[\hat{i} \cos(kt) - \hat{j} \sin(kt)]$ , where A and k are constants. The angle between the force and the momentum is

- (a)  $0^\circ$  (b)  $30^\circ$   
 (c)  $45^\circ$  (d)  $90^\circ$  [IIT 07]

9. When a bicycle is in motion, the force of friction exerted by ground on the two wheels is such that, it acts

- (a) in the backward direction on the front wheel and in the forward direction on the rear wheel.  
 (b) in the forward direction on the front wheel and in the backward direction on the rear wheel.  
 (c) in the backward direction on both the front and the rear wheels.  
 (d) in the forward direction on both the front and the rear wheels. [IIT 90]

10. A block of mass 2 kg rests on a rough inclined plane making an angle  $30^\circ$  with the horizontal. The coefficient of static friction between the block and the plane is 0.7. The frictional force on the block is

- (a) 9.8 N (b)  $0.7 \times 9.8 \sqrt{3}$  N  
 (c)  $9.8 \sqrt{3}$  (d)  $0.7 \times 9.8$  N [IIT 80]

11. A block of mass 0.1 kg is held against a wall applying a horizontal force of 5 N on the block. If the co-efficient of friction between the block and the wall is 0.5, the magnitude of the frictional force acting on the block is

- (a) 2.5 N (b) 0.98 N  
(c) 4.9 N (d) 0.49 N [IIT 94]

12. A block of mass  $m$  is at rest under the action of force  $F$  against a wall as shown in the figure. Which of the following statements is incorrect ?

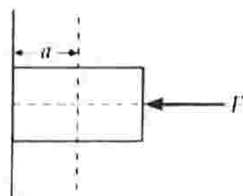

- (a)  $f = mg$ ; where  $f$  is frictional force  
(b)  $F = N$ ; where  $N$  is normal force  
(c)  $F$  will not produce torque  
(d)  $N$  will not produce torque. [IIT 05]

13. What is the maximum value of the force  $F$  such that the block shown in the arrangement, does not move ?

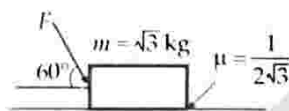

- (a) 20 N (b) 10 N  
(c) 12 N (d) 15 N [IIT 03]

14. A block  $P$  of mass  $m$  is placed on a horizontal frictionless plane. A second block of same mass  $m$  is placed on it and is connected to a spring of spring constant  $k$ . The two blocks are pulled by distance  $A$ . Block  $Q$  oscillates without slipping. What is maximum value of frictional force between the two blocks ?

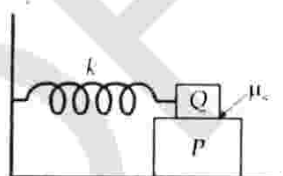

- (a)  $kA/2$  (b)  $kA$   
(c)  $\mu mg$  (d) zero. [IIT 80]

15. A weight  $W$  rests on a rough horizontal plane. If the angle of friction be  $\theta$ , the least force that will move the body along the plane will be

- (a)  $W \cos \theta$  (b)  $W \tan \theta$   
(c)  $W \cot \theta$  (d)  $W \sin \theta$  [IIT 87]

16. An insect crawls up a hemispherical surface very slowly as shown in the figure. The coefficient of friction between the surface and the insect is  $1/3$ . If the line joining the centre of the hemispherical surface to the insect makes an

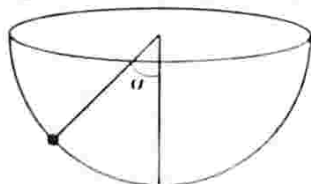

angle  $\alpha$  with the vertical, the maximum possible value of  $\alpha$  is given by

- (a)  $\cot \alpha = 3$  (b)  $\tan \alpha = 3$   
(c)  $\sec \alpha = 3$  (d)  $\operatorname{cosec} \alpha = 3$  [IIT 01]

17. A long horizontal rod had a bead which can slide along its length and initially placed at a distance  $L$  from one end  $A$  of the rod. The rod is set in angular motion about  $A$  with constant angular acceleration  $\alpha$ . If the coefficient of friction between the rod and the bead is  $\mu$ , and gravity is neglected, then the time after which the bead starts slipping is

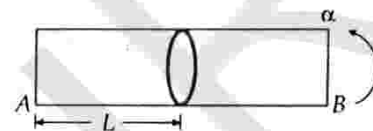

- (a)  $\sqrt{\mu / \alpha}$  (b)  $\mu / \sqrt{\alpha}$   
(c)  $1 / \sqrt{\mu \alpha}$  (d) infinitesimal [IIT 2K]

18. A car is moving in a circular horizontal track of radius 10 m with a constant speed of 10 m/s. A plumb bob is suspended from the roof of the car by a light rigid rod. The angle made by the rod with the track ( $g = 10 \text{ m/s}^2$ ) is

- (a) zero (b)  $30^\circ$   
(c)  $45^\circ$  (d)  $60^\circ$  [IIT 92]

19. A small block is shot into each of the four tracks as shown below. Each of the tracks rises to the same height. The speed with which the block enters the track is the same in all cases. At the highest point of the track, the normal reaction is maximum in

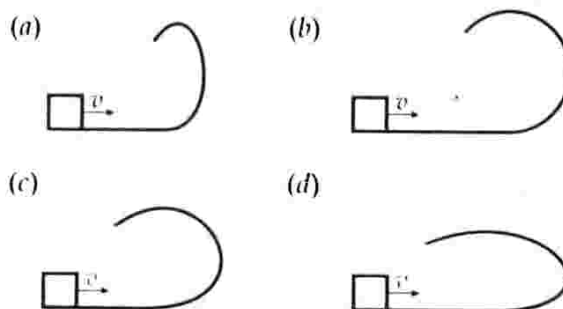

[IIT 01]

20. The driver of a car suddenly sees a broad wall in front of him. He should

- (a) brake sharply (b) turn sharply  
(c) (a) and (b) both (d) none of the above.

[IIT 87]

21. A stone tied to a string of length  $l$  is whirled in a vertical circle with the other end of the string at the centre. At a certain instant of time, the stone is at its lowest position and has a speed  $u$ . The magnitude of



34. A boy is pushing a ring of mass 2 kg and radius 0.5 m with a stick as shown in the figure. The stick applies a force of 2 N on the ring and rolls it without slipping with an acceleration of  $0.3 \text{ m/s}^2$ . The

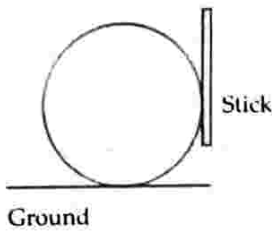

coefficient of friction between the ground and the ring is large enough that rolling always occurs and the coefficient of friction between the stick and the ring is  $(P/10)$ . Find the value of  $P$ . [IIT 2011]

35. A train is moving along a straight line with a constant acceleration  $a$ . A boy standing in the train throws a ball forward with a speed of 10 m/s, at an angle of  $60^\circ$  to the horizontal. The boy has to move forward by 1.15 m inside the train to catch the ball back at the initial height. Find the acceleration of the train, in  $\text{m/s}^2$ . [IIT 2011]

## Answers and Explanations

$$\begin{aligned} 1. (c) \quad a &= \frac{F}{m} = \frac{5 \times 10^4}{3 \times 10^7} \\ &= \frac{5}{3} \times 10^{-3} \text{ ms}^{-2} \end{aligned}$$

Speed attained by the ship,

$$\begin{aligned} v &= \sqrt{2as} = \sqrt{2 \times \frac{5}{3} \times 10^{-3} \times 3} = \sqrt{10^{-2}} \\ &= 10^{-1} = 0.1 \text{ ms}^{-1}. \end{aligned}$$

2. (c) This is because the liquid experiences a backward force of reaction.

3. (b) At  $t=0$ , the momentum of the two-particle system is

$$\vec{p}_i = m_1 \vec{v}_1 + m_2 \vec{v}_2$$

The collision between two particles does not affect the momentum of the system.

An external force  $(m_1 + m_2)g$  acts on the system. Impulse of this force in time  $t=0$  to  $t=2t_0$  is  $(m_1 + m_2)g \times 2t_0$

Change in momentum = Impulse

$$|(m_1 \vec{v}'_1 + m_1 \vec{v}'_2) - (m_1 \vec{v}_1 + m_2 \vec{v}_2)| = 2(m_1 + m_2)gt_0$$

4. (b) Before the string is cut, the upward stretching force on the spring is

$$kx = 3mg$$

After the string is cut, the free body diagrams for the two blocks can be shown as in adjacent figure.

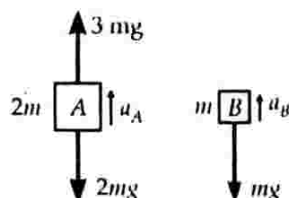

$$\text{For block A : } 2ma_A = 3mg - 2mg$$

$$\text{or } a_A = g/2$$

$$\text{For block B : } ma_B = mg$$

$$\text{or } a_B = g.$$

5. (d) For the block of mass  $M$  to be in equilibrium, the tension in the string,  $T = Mg$ . Free body diagram of pulley is shown. The force on the pulley by the clamp must balance the resultant of forces shown in the figure. This force has magnitude,

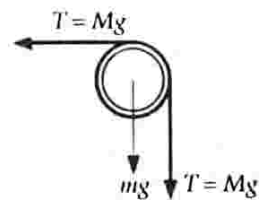

$$F = \sqrt{(Mg + mg)^2 + (Mg)^2}$$

$$= \sqrt{(M + m)^2 + M^2} g.$$

6. (c) Free body diagram for bodies of masses  $m$  and  $\sqrt{2}m$  are shown below.

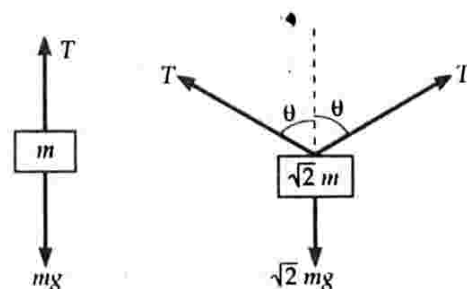

For equilibrium of mass  $m$

$$T = mg \quad \dots(i)$$

For equilibrium of mass  $\sqrt{2}m$ ,

$$2T \cos \theta = \sqrt{2}mg \quad \dots(ii)$$

Dividing (ii) by (i), we get

$$\cos \theta = \frac{1}{\sqrt{2}} \quad \therefore \theta = 45^\circ.$$

7. (b)

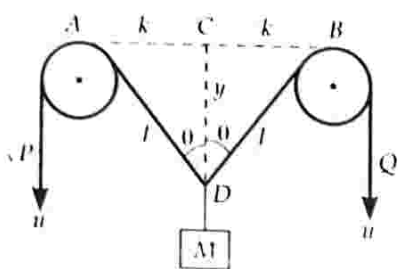

In right angled  $\triangle ACD$ ,  $AC = k$  remains constant. When ends  $P$  and  $Q$  move downwards,  $l$  and  $y$  change in accordance with the equation

$$l^2 = k^2 + y^2$$

Differentiating w.r.t. time  $t$ , we get

$$2l \frac{dl}{dt} = 0 + 2y \frac{dy}{dt}$$

or  $2l \times u = 2y \times v_M$

$$\therefore v_M = \frac{l}{y} \times u = \frac{u}{\cos \theta}$$

8. (d) Given  $\vec{p}(t) = A[\hat{i} \cos(kt) - \hat{j} \sin(kt)]$

$$\therefore \vec{F} = \frac{d\vec{p}}{dt} = Ak[-\hat{i} \sin(kt) - \hat{j} \cos(kt)]$$

$$\vec{F} \cdot \vec{p} = -\sin(kt)\cos(kt) + \sin(kt)\cos(kt)$$

or  $\vec{F} \cdot \vec{p} = 0 \Rightarrow \vec{F} \perp \vec{p}$

9. (a) When a bicycle is in motion, the force of friction acts in the backward direction on the front wheel and in the forward direction on the rear wheel.

10. (a)

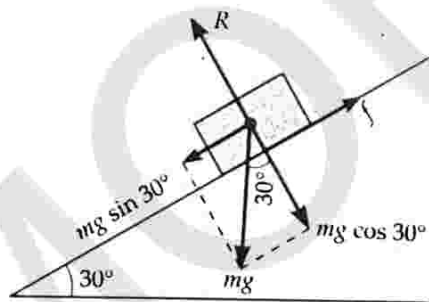

For equilibrium of the block,

$$f = mg \sin 30^\circ = 2 \times 9.8 \times \frac{1}{2} = 9.8 \text{ N.}$$

11. (b) Different forces acting on the block are shown in the figure.

In equilibrium,

$$R = 5 \text{ N}$$

Force of friction,

$$f = \mu R = mg = 0.1 \times 9.8 \text{ N} = 0.98 \text{ N.}$$

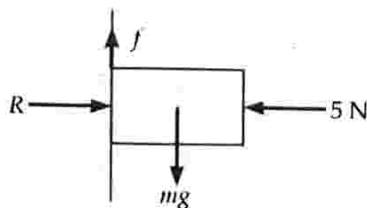

12. (d) We consider the equilibrium of coplanar forces.

Horizontally,  $F = N$ , where  $N$  is the normal force.

Vertically,  $f = mg$ , where  $f$  is the force of friction.

Torque due to  $F$  is zero as its line of action passes through the centre  $C$ .

As the body is in equilibrium,

$$\vec{\tau}_f + \vec{\tau}_N = 0$$

Now  $\vec{\tau}_f \neq 0$ .

$\therefore \vec{\tau}_N \neq 0$

Therefore,  $N$  does not produce torque, is wrong.

The only correct option is (d).

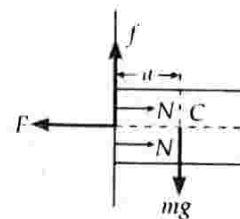

13. (a) For vertical equilibrium of the block,

$$R = mg + F \sin 60^\circ$$

$$= \sqrt{3}g + \frac{\sqrt{3}}{2}F$$

For no motion of the block,

$$f \geq F \cos 60^\circ.$$

or  $\mu R \geq F \cos 60^\circ$

or  $\frac{1}{2\sqrt{3}} \left( \sqrt{3}g + \frac{\sqrt{3}}{2}F \right) \geq \frac{F}{2}$

or  $g \geq \frac{F}{2}$

or  $F \leq 2g$  or  $F_{\max} = 20 \text{ N.}$

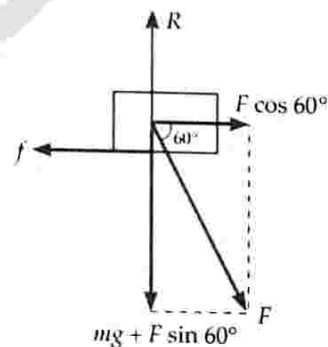

14. (a) The block  $Q$  oscillates but does not slip on  $P$ . This indicates acceleration is same both for  $Q$  and  $P$ . A force of friction acts between the two blocks but the horizontal plane is frictionless. The system  $P$ - $Q$  oscillates with angular frequency,

$$\omega = \sqrt{\frac{k}{m+m}} = \sqrt{\frac{k}{2m}}$$

Maximum acceleration of the system will be

$$a_{\max} = \omega^2 A = \frac{kA}{2m}$$

This acceleration is provided to the lower block by the force of friction.

$$\therefore f_{\max} = ma_{\max} = m \frac{kA}{2m} = \frac{kA}{2}$$

15. (b) The least force required to move weight  $W$  on a horizontal plane is equal to the force of friction,

$$f = \mu R = \mu mg$$

or  $f = W \tan \theta$  [ $mg = W, \mu = \tan \theta$ ]

16. (a) For equilibrium,

$$R = mg \cos \alpha$$

$$f = mg \sin \alpha$$

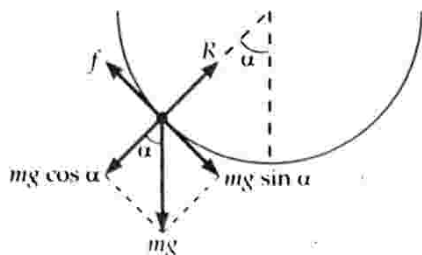

But  $f = \mu R = \mu mg \cos \alpha$

$$\therefore \mu mg \cos \alpha = mg \sin \alpha$$

or  $\cot \alpha = \frac{1}{\mu} = \frac{1}{1/3} = 3$ .

17. (a) Linear acceleration of the bead,  $a = L\alpha$

Force of reaction on the bead due to thread,

$$R = ma = mL\alpha$$

After time  $t$ , angular velocity of the bead,

$$\omega = \alpha t$$

$\therefore$  Centripetal acceleration of the bead

$$= \omega^2 L = \alpha^2 t^2 L$$

Limiting force of friction

$$= \mu R = \mu mL\alpha$$

For slipping,

$$\mu mL\alpha = m\alpha^2 t^2 L$$

or  $t = \sqrt{\frac{\mu}{\alpha}}$

18. (c)

$$T \sin \theta = \frac{mv^2}{R}$$

(centripetal force)

$$T \cos \theta = mg$$

$$\therefore \tan \theta = \frac{v^2}{Rg}$$

$$= \frac{(10)^2}{10 \times 10} = 1$$

or  $\theta = 45^\circ$ .

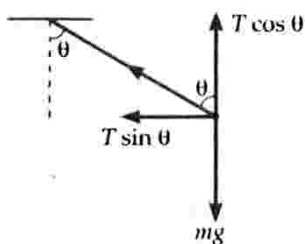

19. (a) As the block rises to the same height in all the four cases, by conservation of energy, speed of the block (say,  $v_0$ ) at the highest point will be same in all the four cases.

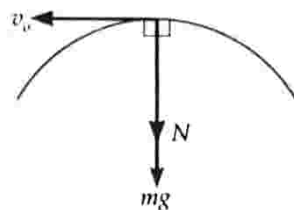

If  $R$  is the radius of curvature of the track and  $N$  the normal reaction, then the centripetal force will be

$$N + mg = \frac{mv_0^2}{R}$$

Clearly,  $N$  will be maximum when  $R$  is minimum. This occurs when the track is most sharply curved.

20. (a) Refer to the solution of Problem 15 on Page 5.73.

21. (d) By conservation of energy,

$$\frac{1}{2} mu^2 - \frac{1}{2} mv^2 = mgL$$

or  $v^2 = u^2 - 2gL$

Change in velocity,

$$\Delta \vec{v} = \vec{v}_f - \vec{v}_i$$

$$= v \hat{j} - u \hat{i}$$

$$\therefore |\Delta \vec{v}| = \sqrt{v^2 + u^2} = \sqrt{u^2 - 2gL + u^2} = \sqrt{2(u^2 - gL)}$$

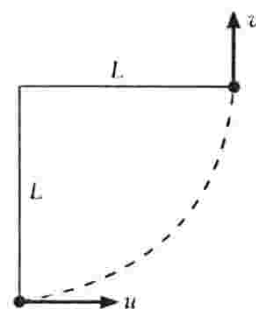

22. (b) The situation is shown in the figure. The two particles move towards each other. At any instant, the separation between them is  $2x$ .

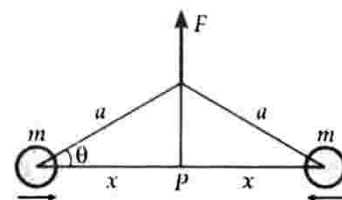

Let  $T$  be the tension in the string. Then the forces acting at point  $P$  and on either mass  $m$  will be as shown in the figures.

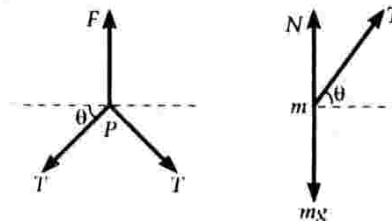

For equilibrium of point  $P$ ,

$$2T \sin \theta = F$$

For equilibrium of each mass  $m$ ,

$$N + T \sin \theta - mg = 0$$

and  $T \cos \theta = ma_m$

$$\therefore \frac{ma_m}{l} = \frac{T \cos \theta}{2T \sin \theta} = \frac{1}{2} \cot \theta$$

$$\text{or } a_m = \frac{l}{2m} \cot \theta = \frac{F}{2m} \cdot \frac{x}{\sqrt{a^2 - x^2}}$$

23. (b) Block will topple at an angle  $\theta$  given by

$$mg \sin \theta \times \frac{15}{2} = mg \cos \theta \times 5$$

$$\text{or } \tan \theta = \frac{2}{3} \Rightarrow \theta < 60^\circ$$

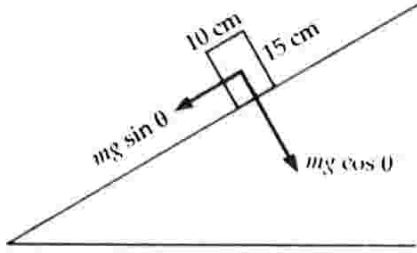

Sliding will occur at the angle of repose given by

$$\tan \theta = \mu = \sqrt{3} \text{ i.e., } \theta = 60^\circ$$

Hence the block will topple before sliding and option (b) is correct.

24. (a) (i) When  $P < mg \sin \theta$

$$P + f = mg \sin \theta$$

$$f = mg \sin \theta - P > 0, \text{ acting upwards}$$

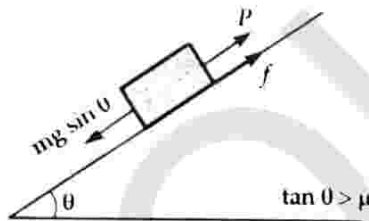

(ii) When  $P = mg \sin \theta$ ,  $f = 0$

(iii) When  $P > mg \sin \theta$

$$f + mg \sin \theta = P$$

$$f = P - mg \sin \theta < 0, \text{ acting downwards}$$

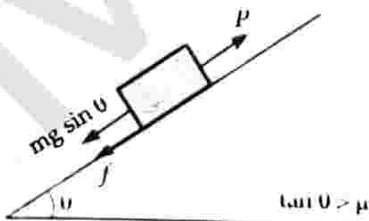

25. (d) The horizontal component of the tension  $T$  provides the necessary centripetal force.

$$\therefore T \sin \theta = mr\omega^2$$

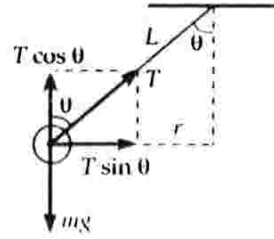

$$\text{But } \frac{r}{L} = \sin \theta \Rightarrow r = L \sin \theta$$

$$\therefore T \sin \theta = m(L \sin \theta)\omega^2$$

$$\text{or } \omega = \sqrt{\frac{T}{mL}} = \sqrt{\frac{324}{0.5 \times 0.5}} = \frac{18}{0.5} = 36 \text{ rad/s}$$

$$26. (d) t = \sqrt{\frac{2h}{g}} = \sqrt{\frac{2 \times 5}{10}} = 1 \text{ s}$$

By conservation of linear momentum,

$$v \times 0.01 = 0.2 \times 20 + 0.01 \times 100$$

$$\Rightarrow v = 500 \text{ m/s}$$

27. (b) and (d) The rotating or revolving earth is an accelerated frame of reference. So it cannot be an inertial frame. Hence options (b) and (d) are correct.

28. (a), (d) Net linear momentum before collision,

$$\vec{p}_i = \vec{p}_1 + \vec{p}_2 = p_1 \hat{i} - p_1 \hat{i} = 0$$

As no external force is acting on the balls, so net linear momentum is conserved.

$$\vec{p}_f = \vec{p}'_1 + \vec{p}'_2 = 0$$

In option (a),

$$\vec{p}'_1 + \vec{p}'_2 = (a_1 + a_2)\hat{i} + (b_1 + b_2)\hat{j} + c_1\hat{k} \neq 0$$

[ $\because c_1$  is non-zero]

In option (d),

$$\vec{p}'_1 + \vec{p}'_2 = (a_1 + a_2)\hat{i} + 2b_1\hat{j} \neq 0$$

[ $\because b_1$  is non-zero]

29. (c) There is nothing wrong in statement - 1. But statement - 2 is false.

Hence option (c) is correct.

30. (b) The dishes will remain on the table due to inertia of rest and not due to action-reaction forces. Statement - 2 is not a correct explanation of statement - 1. Hence option (b) is correct.

31. (b) Normal contact force is greater in pushing than in pulling.

32.

0 0 0 8

$$T = \frac{2m_1m_2}{m_1+m_2} \cdot g$$

$$= \frac{2 \times 0.72 \times 0.36}{0.72 + 0.36} \times 10 = 4.8 \text{ N}$$

$$a = \frac{m_1 - m_2}{m_1 + m_2} \cdot g$$

$$= \frac{0.72 - 0.36}{0.72 + 0.36} \times 10 = \frac{10}{3} \text{ ms}^{-2}$$

$$s = ut + \frac{1}{2}at^2$$

$$= 0 + \frac{1}{2} \times \frac{10}{3} (1)^2 = \frac{10}{3} \text{ m}$$

$$W = T \cdot s = 4.8 \times \frac{10}{6} = 8 \text{ J.}$$

33.

0 0 0 5

Force required to just push the block up the inclined plane

$$= 3 \times \text{Force required just to prevent the block from sliding down}$$

$$\text{or } (mg \sin \theta + \mu mg \cos \theta) = 3(mg \sin \theta - \mu mg \cos \theta)$$

$$\Rightarrow 1 + \mu = 3(1 - \mu)$$

$$\Rightarrow \mu = 0.5$$

$$\Rightarrow N = 10\mu = 5$$

34.

0 0 0 4

The force of the stick (2 N) tends to slide the point of contact of the ring with the ground. But the force of friction  $f_1$  presents it from slipping and produces a torque which starts rolling the ring. Also, a force a friction  $f_2$  acts between the ring and the stick.

In horizontal direction,

$$F_{\text{net}} = ma \quad \text{or} \quad 2 - f_1 = 2 \times 0.3$$

$$\therefore f_1 = 1.4 \text{ N}$$

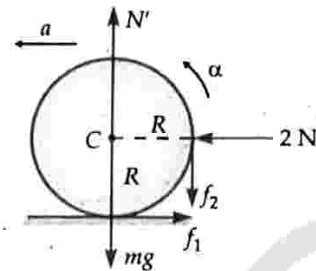

Applying  $\tau = I\alpha$  about C, we get

$$(f_2 - f_1)R = I\alpha = I \frac{a}{R} \quad [\because \text{For rolling } a = R\alpha]$$

$$\therefore [1.4 - \mu \times 2] \times 0.5 = 2 \times (0.5)^2 \times \frac{0.3}{0.5}$$

$$[\because I = MR^2]$$

$$\therefore \mu = 0.4$$

Given  $\mu = \frac{P}{10} \therefore P = 4$

35.

0 0 0 5

Time of flight of the ball is given by

$$t = \frac{2u \sin \theta}{g}$$

$$= \frac{2 \times 10 \sin 60^\circ}{10} = \sqrt{3} \text{ s}$$

The acceleration of the boy due to the pseudo force is negative.

$$\therefore s_x = u_x t + \frac{1}{2} a_x t^2$$

$$1.15 = 5 \times t - \frac{1}{2} a \times t^2$$

$$1.15 = 5 \times \sqrt{3} - \frac{3}{2} a$$

$$\frac{3a}{2} = 5 \times 1.73 - 1.15 = 8.65 - 1.15$$

$$\frac{3a}{2} = 7.5$$

$$\text{or } a = \frac{15}{3} = 5 \text{ m/s}^2$$

## AIEEE

1: A rocket with a lift-off mass  $3.5 \times 10^4$  kg is blasted upwards with an initial acceleration of  $10 \text{ ms}^{-2}$ . Then the initial thrust blast is

- (a)  $3.5 \times 10^5$  N      (b)  $7.0 \times 10^5$  N  
(c)  $14.0 \times 10^5$  N      (d)  $1.75 \times 10^5$  N      [AIEEE 03]

2. A block of mass  $m$  is connected to another block of mass  $M$  by a massless spring of spring constant  $k$ . The blocks are kept on a smooth horizontal plane. Initially the blocks are at rest and the spring is unstretched. Then, a constant force  $F$  starts acting on

the block of mass  $M$  to pull it. Find the force on block of mass  $m$ .

- (a)  $\frac{mF}{M}$  (b)  $\frac{(M+m)F}{m}$   
 (c)  $\frac{mF}{(M+m)}$  (d)  $\frac{MF}{(M+m)}$  [AIEEE 07]

3. A block of mass  $M$  is pulled along a horizontal frictionless surface by a rope of mass  $m$ . If a force  $P$  is applied at the free end of the rope, the force exerted by the rope on the block is

- (a)  $\frac{Pm}{(M+m)}$  (b)  $\frac{Pm}{(M-m)}$   
 (c)  $P$  (d)  $\frac{PM}{(M+m)}$  [AIEEE 03]

4. A particle of mass  $0.3$  kg is subjected to a force  $F = -kx$  with  $k = 15 \text{ Nm}^{-1}$ . What will be its initial acceleration, if it is released from a point  $20$  cm away from the origin?

- (a)  $3 \text{ m s}^{-2}$  (b)  $15 \text{ m s}^{-2}$   
 (c)  $5 \text{ m s}^{-2}$  (d)  $10 \text{ m s}^{-2}$  [AIEEE 05]

5. Three forces start acting simultaneously on a particle moving with velocity  $\vec{v}$ . These forces are

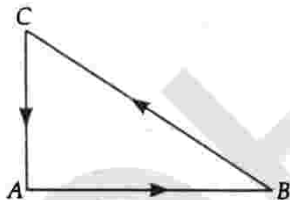

represented in magnitude and direction by the three sides of a triangle  $ABC$  as shown in the figure. The particle will now move with velocity

- (a) greater than  $\vec{v}$   
 (b)  $|\vec{v}|$  in the direction of the largest force  $BC$   
 (c)  $\vec{v}$ , remaining unchanged  
 (d) less than  $\vec{v}$ . [AIEEE 03]

6. When forces  $F_1$ ,  $F_2$  and  $F_3$  are acting on a particle of mass  $m$  such that  $F_2$  and  $F_3$  are mutually perpendicular, then the particle remains stationary. If the force  $F_1$  is now removed, then the acceleration of the particle is

- (a)  $F_1 / m$  (b)  $F_2 F_3 / mF$   
 (c)  $(F_2 - F_3) / m$  (d)  $F_2 / m$  [AIEEE 02]

7. A ball of mass  $0.2$  kg is thrown vertically upwards by applying a force by hand. If the hand moves  $0.2$  m while applying the force and the ball goes upto  $2$  m height further, find the magnitude of the force. Take  $g = 10 \text{ ms}^{-2}$ .

- (a)  $20 \text{ N}$  (b)  $22 \text{ N}$   
 (c)  $4 \text{ N}$  (d)  $16 \text{ N}$  [AIEEE 06]

8. A player caught a cricket ball of mass  $150$  g moving at a rate of  $20 \text{ ms}^{-1}$ . If the ball catching process is completed in  $0.1$  s, the force on the blow exerted by the ball on the hand of the player is equal to

- (a)  $30 \text{ N}$  (b)  $300 \text{ N}$   
 (c)  $150 \text{ N}$  (d)  $3 \text{ N}$  [AIEEE 06]

9. A machine gun fires a bullet of mass  $40$  g with a velocity  $1,200 \text{ ms}^{-1}$ . The man holding it, can exert a maximum force of  $144 \text{ N}$  on the gun. How many bullets can he fire per second at the most?

- (a) One (b) Four  
 (c) Two (d) Three [AIEEE 04]

10. A body of mass  $3.513$  kg is moving along the  $x$ -axis with a speed of  $5.00 \text{ ms}^{-1}$ . The magnitude of its momentum is

- (a)  $17.6 \text{ kg ms}^{-1}$  (b)  $17.565 \text{ kg ms}^{-1}$   
 (c)  $17.56 \text{ kg ms}^{-1}$  (d)  $17.57 \text{ kg ms}^{-1}$  [AIEEE 08]

11. A lift is moving down with acceleration  $a$ . A man in the lift drops a ball inside the lift. The acceleration of the ball as observed by the man in the lift and a man standing stationary on the ground are respectively.

- (a)  $g, g$  (b)  $g - a, g - a$   
 (c)  $g - a, g$  (d)  $a, g$  [AIEEE 02]

12. A light spring balance hangs from the hook of the other light spring balance and a block of mass  $M$  kg hangs from the former one. Then, the true statement about the scale reading is

- (a) Both the scales read  $M$  kg each  
 (b) The scale of the lower one reads  $M$  kg and of the upper one zero.  
 (c) The reading of the two scales can be anything but the sum of the readings will be  $M$  kg  
 (d) Both the scales read  $M/2$  kg. [AIEEE 03]

13. A spring balance is attached to the ceiling of a lift. A man hangs his bag on the spring and the spring balance reads  $49 \text{ N}$ , when the lift is stationary. If the lift moves downward with an acceleration of  $5 \text{ ms}^{-2}$ , the reading of the spring balance will be

- (a)  $24 \text{ N}$  (b)  $74 \text{ N}$   
 (c)  $15 \text{ N}$  (d)  $49 \text{ N}$  [AIEEE 03]

14. Three identical blocks of masses  $m=2$  kg are drawn by a force  $10.2$  N on a frictionless surface. What

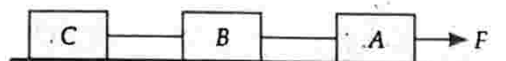

is the tension (in N) in the string between the blocks B and C?

- (a) 9.2 (b) 8  
(c) 3.4 (d) 9.8 [AIEEE 02]

15. Two masses  $m_1 = 5$  kg and  $m_2 = 4.8$  kg tied to a string are hanging over a light frictionless pulley. What is the acceleration of the masses, when left free to move? Given :  $g = 9.8 \text{ ms}^{-2}$ .

- (a)  $0.2 \text{ ms}^{-2}$   
(b)  $9.8 \text{ ms}^{-2}$   
(c)  $5 \text{ ms}^{-2}$   
(d)  $4.8 \text{ ms}^{-2}$  [AIEEE 04]

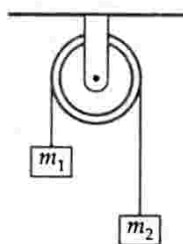

16. A light string passing over a smooth light pulley connects two blocks of masses  $m_1$  and  $m_2$  (vertically). If the acceleration of the system is  $g/8$ , then the ratio of the masses  $m_2/m_1$  is

- (a) 8 : 1 (b) 9 : 7  
(c) 4 : 3 (d) 5 : 3 [AIEEE 02]

17. One end of massless rope, which passes over a massless and frictionless pulley  $P$  is tied to a hook  $C$ , while the other end is free. Maximum tension that the

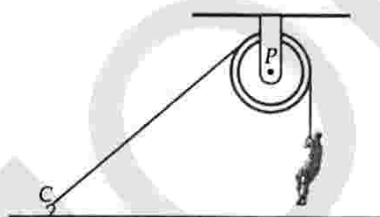

rope can bear is  $640$  N. With what value of maximum safe acceleration (in  $\text{ms}^{-2}$ ) can a man of  $40$  kg climb on the rope? Take  $g = 10 \text{ ms}^{-2}$ .

- (a) 16 (b) 12  
(c) 8 (d) 6 [AIEEE 02]

18. A block is kept on a frictionless inclined surface with angle of inclination  $\alpha$ . The incline is given an

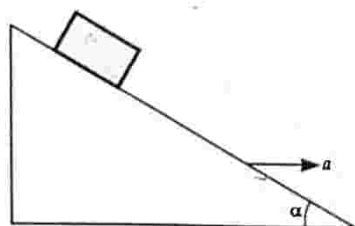

acceleration  $a$  to keep the block stationary. Then  $a$  is equal to

- (a)  $g / \tan \alpha$  (b)  $g \operatorname{cosec} \alpha$   
(c)  $g$  (d)  $g \tan \alpha$  [AIEEE 05]

19. A marble block of mass  $2$  kg lying on ice, when given a velocity of  $6 \text{ ms}^{-1}$ , is stopped by friction in  $10$  s. Then the coefficient of friction is

- (a) 0.02 (b) 0.03  
(c) 0.06 (d) 0.01 [AIEEE 03]

20. A block rests on a rough inclined plane making an angle of  $30^\circ$  with the horizontal. The coefficient of static friction between the block and the plane is  $0.8$ . If the frictional force on the block is  $10$  N, the mass of the block (in kg) ( $g = 10 \text{ ms}^{-2}$ ) is

- (a) 2.0 (b) 4.0  
(c) 1.6 (d) 2.5 [AIEEE 04]

21. A horizontal force of  $10$  N is necessary to just hold a block stationary against a wall. The coefficient

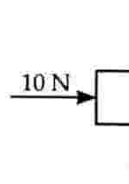

of friction between the block and the wall is  $0.2$ . The weight of the block is

- (a) 20 N (b) 50 N  
(c) 100 N (d) 2 N [AIEEE 03]

22. The upper half of an inclined plane with inclination  $\theta$  is perfectly smooth, while the lower half is rough. A body starting from rest at the top will again come to rest at the bottom, if the coefficient of friction for the lower half is given by

- (a)  $2 \tan \theta$  (b)  $\tan \theta$   
(c)  $2 \sin \theta$  (d)  $2 \cos \theta$  [AIEEE 05]

23. A smooth block is released at rest on a  $45^\circ$  incline and then slides a distance  $d$ . The time taken to slide is  $n$  times as much to slide on rough incline than on a smooth incline. The coefficient of friction is

- (a)  $\mu_k = 1 - \frac{1}{n^2}$  (b)  $\mu_k = \sqrt{1 - \frac{1}{n^2}}$   
(c)  $\mu_s = 1 - \frac{1}{n^2}$  (d)  $\mu_s = \sqrt{1 - \frac{1}{n^2}}$  [AIEEE 05]

24. A particle is acted upon by a force of constant magnitude which is always perpendicular to the

velocity of the particle. The motion of the particle takes place in a plane.

It follows that

- (a) its velocity is constant
- (b) its acceleration is constant
- (c) its kinetic energy is constant
- (d) it moves in a straight line.

[AIEEE 04]

25. An annular ring with inner and outer radii  $R_1$  and  $R_2$  is rolling without slipping with a uniform angular speed. The ratio of the forces  $F_1 / F_2$  experienced by two identical particles situated on the inner and outer parts of the ring is

- (a)  $\frac{R_2}{R_1}$
- (b)  $\left(\frac{R_1}{R_2}\right)^2$
- (c) 1
- (d)  $\frac{R_1}{R_2}$

[AIEEE 05]

26. The maximum velocity (in  $\text{ms}^{-1}$ ) with which a car driver must traverse a flat curve of radius 150 m and coefficient of friction 0.6 to avoid skidding is

- (a) 60
- (b) 30
- (c) 15
- (d) 25

[AIEEE 02]

27. The figure shows the position-time ( $x-t$ ) graph of one-dimensional motion of a body of mass 0.4 kg. The magnitude of each impulse is

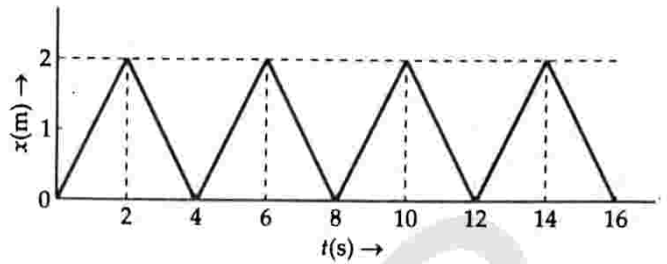

- (a) 0.2 Ns
- (b) 0.4 Ns
- (c) 0.8 Ns
- (d) 1.6 Ns

[AIEEE 2010]

28. Two fixed frictionless inclined planes making angles  $30^\circ$  and  $60^\circ$  with the vertical are shown in the figure. Two blocks A and B are placed on the two

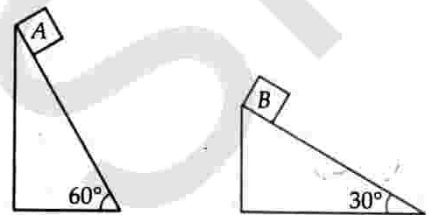

planes. What is the relative vertical acceleration of A with respect of B ?

- (a)  $4.9 \text{ ms}^{-2}$  in vertical direction
- (b)  $4.9 \text{ ms}^{-2}$  in horizontal direction
- (c)  $9.8 \text{ ms}^{-2}$  in vertical direction
- (d) zero

[AIEEE 2010]

## Answers and Explanations

1. (b) Initial thrust =  $ma + mg$

$$= m(a + g) = 3.5 \times 10^3 (10 + 10) \text{ N}$$

$$= 7.0 \times 10^5 \text{ N.}$$

2. (c) Accelerating of the system,  $a = \frac{F}{M + m}$

Force on block of mass  $m$ ,  $F' = ma = \frac{mF}{m + M}$

3. (d) Refer to the solution of Problem 80 on page 5.67.

4. (d) Refer to the solution of Problem 79 on page 5.67.

5. (c) As the three forces are represented by the three sides of a triangle taken in the same order, their resultant is zero. Hence the velocity of the particle will remain unchanged.

6. (a) Refer to the solution of Problem 81 on page 5.67.

7. (b) For motion of the ball, just after the throwing process :

$$v = 0, s = 2 \text{ m}, a = -g = -10 \text{ ms}^{-2}$$

As  $v^2 - u^2 = 2as$

$$\therefore 0^2 - u^2 = 2 \times (-10) \times 2$$

or  $u = \sqrt{40} \text{ ms}^{-1}$

For motion of the ball during the throwing process :

$$u = 0, v = \sqrt{40} \text{ ms}^{-1}, s = 0.2 \text{ m}$$

As  $v^2 - u^2 = 2as$

$$\therefore 40 - 0^2 = 2a \times 0.2$$

or  $a = \frac{40}{0.4} = 100 \text{ ms}^{-2}$

Force applied on the ball produces acceleration  $a$  and also overcomes the weight of the ball.

$$\therefore F = ma + mg = m(a + g)$$

$$= 0.2(100 + 10) = 22 \text{ N.}$$



8. (a) Impulse = Change in momentum

or  $F \times t = m(v - u)$

or  $F = \frac{m(v - u)}{t} = \frac{0.150(0 - 20)}{0.1}$   
 $= -30 \text{ N.}$

9. (d) Refer to the solution of Example 13 on page 5.13.

10. (b)  $p = mv = 3.513 \times 5.00 = 17.565 \text{ kg ms}^{-1}$ .

11. (c) When the ball dropped, its acceleration is  $g$  as is observed by a man standing stationary on the ground. Now the man inside the lift has downward acceleration  $a$ , the acceleration of the ball as observed by this man will be  $g - a$ .

12. (a) As the suspended spring balance is lighter one, both the scales will read  $M \text{ kg}$  each.

13. (a) Refer to the solution of Problem 82 on page 5.67.

14. (c) Free body diagrams for the three blocks are shown below :

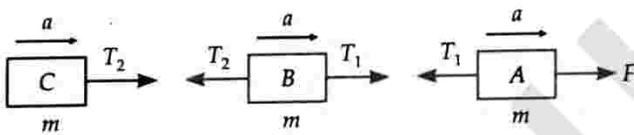

Applying Newton's second law,

$$F - T_1 = ma$$

$$T_1 - T_2 = ma$$

$$T_2 = ma$$

Adding the three equations, we get

$$F = 3ma$$

or  $a = \frac{F}{3m}$

$$\therefore T_2 = ma = \frac{F}{3}$$

$$= \frac{10.2 \text{ N}}{3} = 3.4 \text{ N.}$$

15. (a)  $a = \frac{(m_1 - m_2)g}{m_1 + m_2} = \frac{(5 - 48) \times 9.8}{5 + 48}$   
 $= 0.2 \text{ ms}^{-2}$ .

16. (b) Refer to the solution of Problem 18 on page 5.69.

17. (d) When the man climbs up the rope with acceleration  $a$ , the tension  $T$  in the rope must be greater than his weight  $mg$ .

$$T - mg = ma$$

or  $a = \frac{T}{m} - g = \frac{640}{40} - 10$   
 $= 16 - 10 = 6 \text{ ms}^{-2}$ .

18. (d) When the incline is given an acceleration  $a$  towards the right, the block receives a reaction  $ma$  towards left.

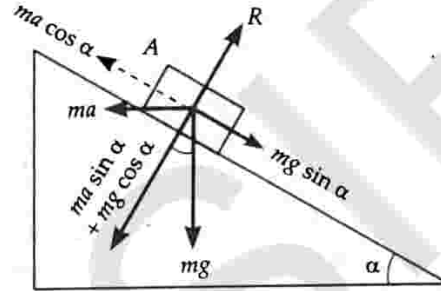

For the block to remain stationary,

$$ma \cos \alpha = mg \sin \alpha$$

or  $a = \frac{g \sin \alpha}{\cos \alpha} = g \tan \alpha$ .

19. (c) Here  $u = 6 \text{ ms}^{-1}$ ,  $v = 0$ ,  $t = 10 \text{ s}$

$$\therefore a = \frac{v - u}{t}$$

$$= \frac{0 - 6}{10} = -0.6 \text{ ms}^{-2}$$

$$\mu = \frac{f}{R} = \frac{ma}{mg} = \frac{a}{g}$$

$$= \frac{0.6}{10} = 0.06.$$

20. (a) As the block is at rest, the component of its weight along the inclined plane balances the force of friction.

$$\therefore mg \sin \theta = f$$

or  $m = \frac{f}{g \sin \theta} = \frac{10}{10 \times \sin 30^\circ} = 2.0 \text{ kg.}$

21. (d) For the block to remain stationary,

$$R = 10 \text{ N, } f = mg$$

But  $f = \mu R$

$$\therefore mg = \mu R = 0.2 \times 10$$

$$= 2 \text{ N.}$$

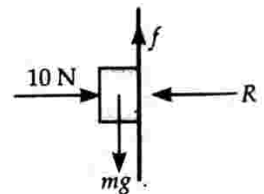

22. (a) As the initial and final speeds of the block are zero,

$$\text{Work done by gravity} = \text{Work done by friction}$$

$$mg \sin \theta \times l = f \times \frac{l}{2}$$

or  $mg \sin \theta \times l = \mu mg \cos \theta \times \frac{l}{2}$

or  $\mu = 2 \tan \theta$ .

23. (c) Refer to the solution of Problem 16 on page 5.74.

24. (c) It is a case of uniform circular motion in which velocity and acceleration vectors change due to change in direction. As the magnitude of velocity remains constant, the kinetic energy is constant.

25. (d)  $m$  is the mass of each particle and  $\omega$  is angular speed of the annular ring, then

$$\frac{F_1}{F_2} = \frac{mR_1\omega^2}{mR_2\omega^2} = \frac{R_1}{R_2}$$

26. (b)  $v_{\max} = \sqrt{\mu r g} = \sqrt{0.6 \times 150 \times 10}$   
 $= \sqrt{900} = 30 \text{ ms}^{-1}$ .

27. (c) Velocity before  $t = 2 \text{ s}$ ,

$$u = \frac{2-0}{2-0} = 1 \text{ ms}^{-1}$$

Velocity after  $t = 2 \text{ s}$ ,

$$v = \frac{0-2}{4-2} = -1 \text{ ms}^{-1}$$

Impulse =  $m(v-u) = 0.4(-1-1) = -0.8 \text{ Ns}$

| Impulse | =  $0.8 \text{ Ns}$

28. (a) If  $a$  is the acceleration along the include plane, then

$$mg \sin \theta = ma \Rightarrow a = g \sin \theta$$

$\therefore$  Vertical component of acceleration =  $g \sin^2 \theta$

Relative vertical acceleration of A with respect to B

$$= g(\sin^2 60^\circ - \sin^2 30^\circ) = g\left(\frac{3}{4} - \frac{1}{4}\right)$$

$$= 9.8 \times \frac{1}{2} = 4.9 \text{ ms}^{-2}, \text{ in vertical direction}$$

### DCE and G.G.S. Indraprastha University Engineering Entrance Exam

(Similar Questions)

1. The dimensions of action are

- (a)  $[M^2LT^{-3}]$  (b)  $[MLT^{-1}]$   
 (c)  $[MLT^{-2}]$  (d)  $[ML^2T^{-1}]$  [DCE 97]

2. If two forces of 5 N each are acting along X- and Y- axes, then the magnitude and direction of resultant is

- (a)  $5\sqrt{2}, \pi/3$  (b)  $5\sqrt{2}, \pi/4$   
 (c)  $-5\sqrt{2}, \pi/3$  (d)  $-5\sqrt{2}, \pi/4$  [DCE 04]

3. If two forces are acting at a point such that the magnitude of each force is 2 N and the magnitude of their resultant is also 2 N, then the angle between the two forces is

- (a)  $120^\circ$  (b)  $60^\circ$   
 (c)  $90^\circ$  (d)  $0^\circ$  [DCE 04]

4. Which of the four arrangements in the figure correctly shows the vector addition of two forces  $F_1$  and  $F_2$  to yield the third force  $F_3$ ? [IPUEE 05]

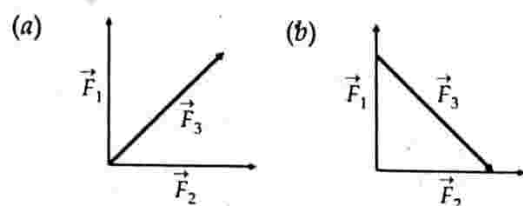

(c)

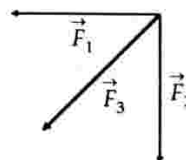

(d)

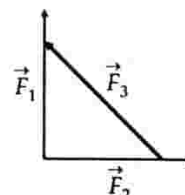

5. A body of mass 8 kg is moved by a force  $F = 3x \text{ N}$ , where  $x$  is the distance covered. Initial position is  $x = 2 \text{ m}$  and the final position is  $x = 10 \text{ m}$ . The initial speed is zero. The final speed is

- (a) 6 m/s (b) 12 m/s  
 (c) 18 m/s (d) 14 m/s [IPUEE 04]

6. A body of mass 5 kg starts from the origin with an initial velocity  $\vec{u} = (30\hat{i} + 40\hat{j}) \text{ m/s}$ . If a constant force  $(-6\hat{i} - 5\hat{j}) \text{ N}$  acts on the body, the time in which the y-component of the velocity becomes zero is

- (a) 5 s (b) 20 s  
 (c) 40 s (d) 80 s [DCE 05]

7. A student unable to answer a question on Newton's laws of motion attempts to pull himself up by tugging on his hair.

He will not succeed

- (a) as the force exerted is small  
 (b) the frictional force while gripping, is small  
 (c) Newton's law of inertia is not applicable to living beings  
 (d) as the force applied is internal to the system.

[IPUEE 06]

8. In the arrangement shown in figure, the strings are light and inextensible. The surface over which blocks are placed is smooth. What is the acceleration of each block ?

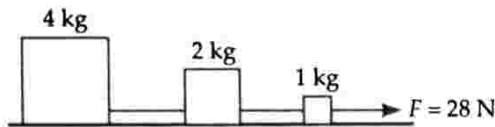

- (a)  $8 \text{ m/s}^2$                       (b)  $4 \text{ m/s}^2$   
 (c)  $2 \text{ m/s}^2$                       (d)  $14 \text{ m/s}^2$                       [DCE 07]

9. Three blocks of masses 2 kg, 3 kg and 5 kg are connected to each other with light string and are then placed on a frictionless surface as shown in the figure. The system is pulled by a force  $F = 10 \text{ N}$ , then tension  $T_1$  is

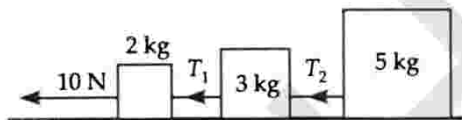

- (a) 1 N                                      (b) 5 N  
 (c) 8 N                                      (d) 10 N                                      [IPUEE 04]

10. Two masses  $m_1$  and  $m_2$  are attached to a string which passes over a frictionless smooth pulley. When  $m_1 = 10 \text{ kg}$ ,  $m_2 = 6 \text{ kg}$ , the acceleration of masses is

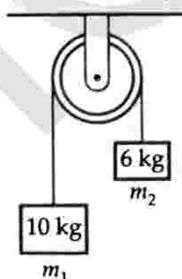

- (a)  $20 \text{ m/s}^2$                       (b)  $5 \text{ m/s}^2$   
 (c)  $2.5 \text{ m/s}^2$                       (d)  $10 \text{ m/s}^2$                       [IPUEE 04]

11. The adjacent figure is the part of a horizontally stretched net. Section AB is stretched with a force of 10 N.

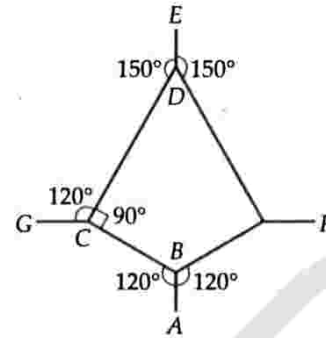

The tensions in the sections BC and BF are

- (a) 10 N, 11 N                      (b) 10 N, 6 N  
 (c) 10 N, 10 N  
 (d) cannot be calculated due to insufficient data                      [IPUEE 06]

12. A plumb line is suspended from a ceiling of a car moving with horizontal acceleration of  $a$ . What will be the angle of inclination with vertical ?

- (a)  $\tan^{-1}\left(\frac{a}{g}\right)$                       (b)  $\tan^{-1}\left(\frac{g}{a}\right)$   
 (c)  $\cos^{-1}\left(\frac{a}{g}\right)$                       (d)  $\cos^{-1}\left(\frac{g}{a}\right)$                       [IPUEE 05]

13. Dimensions of impulse are same as that of

- (a) force                                      (b) momentum  
 (c) energy                                      (d) acceleration                      [DCE 06]

14. Momentum is closely related to

- (a) force                                      (b) impulse  
 (c) velocity                                      (d) kinetic energy                      [DCE 97]

15. A particle is moving in a circle with uniform speed  $v$ . In moving from a point to another diametrically opposite point,

- (a) the momentum changes by  $mv$   
 (b) the momentum changes by  $2mv$   
 (c) the kinetic energy changes by  $(\frac{1}{2})mv^2$   
 (d) the kinetic energy changes by  $mv^2$                       [IPUEE 05]

16. A bullet of mass 10 g is fired from a gun of mass 1 kg. If the recoil velocity is 5 m/s, the velocity of the muzzle is

- (a) 0.05 m/s                                      (b) 5 m/s  
 (c) 50 m/s                                      (d) 500 m/s                                      [IPUEE 04]

17. A person is sitting in a lift accelerating upwards. Measured weight of person will be

- (a) less than actual weight  
 (b) equal to actual weight  
 (c) more than actual weight  
 (d) zero.                                      [DCE 04]

18. A lift is falling under gravity, what is the time period of a pendulum attached to its ceiling ?

- (a) zero (b) infinite  
(c) 1 s (d) 2 s [DCE 98]

19. According to the special theory of relativity, which of the following has same value in all inertial frames ?

- (a) Mass of an object (b) Length of an object  
(c) Velocity of sound (d) Velocity of light. [IPUEE 05]

20. What should be the velocity of an object so that its mass becomes twice of its rest mass ?

- (a)  $3 \times 10^8$  m/s (b)  $2.59 \times 10^8$  m/s  
(c)  $4 \times 10^8$  m/s (d) none of the above. [DCE 04]

21. The velocity of a body of rest mass  $m_0$  is  $\frac{\sqrt{3}}{2}c$  (where  $c$  is the velocity of light in vacuum). Then mass of this body is

- (a)  $(\sqrt{3}/2)m_0$  (b)  $(1/2)m_0$   
(c)  $2m_0$  (d)  $(2/\sqrt{3})m_0$  [IPUEE 04]

22. A body of mass 2 kg is kept stationary by pressing to a vertical wall by a force of 100 N. The coefficient of friction between wall and body is 0.3. Then the frictional force is equal to

- (a) 6 N (b) 20 N  
(c) 600 N (d) 700 N [IPUEE 05]

23. If reaction is  $R$  and coefficient of friction is  $\mu$ , what is work done against friction in moving a body by distance  $d$  ?

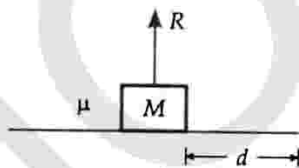

- (a)  $\frac{\mu R d}{4}$  (b)  $2\mu R d$   
(c)  $\mu R d$  (d)  $\mu R d / 2$  [DCE 07]

24. An ice cube is kept on an inclined plane of angle  $30^\circ$ . Coefficient of kinetic friction between block and inclined plane is  $\frac{1}{\sqrt{3}}$ . What is acceleration of block ?

- (a) zero (b)  $2 \text{ m/s}^2$   
(c)  $1.5 \text{ m/s}^2$  (d)  $5 \text{ m/s}^2$  [DCE 06]

25. A small object placed on a rotating horizontal turn table just slips when it is placed at a distance of

4 cm from the axis of rotation. If the angular velocity of the turn-table is doubled the object slips when its distance from the axis of rotation is

- (a) 1 cm (b) 2 cm  
(c) 4 m (d) 8 cm [IPUEE 05]

26. A particle is moving in a vertical circle. The tensions in the string when passing through two positions at angles  $30^\circ$  and  $60^\circ$  from vertical (lowest positions) are  $T_1$  and  $T_2$  respectively. Then

- (a)  $T_1 = T_2$  (b)  $T_2 > T_1$   
(c)  $T_1 > T_2$   
(d) tension in the string always remains the same. [IPUEE 04]

27. Which of the following statements is true ?

- (a) Velocity of light is constant in all media  
(b) Velocity of light in vacuum is maximum  
(c) Velocity of light is same in all reference frames  
(d) Laws of nature have identical form in all reference frames [IPUEE 04]

28. For ordinary terrestrial experiments, the observer in an inertial frame in the following cases is

- (a) a child revolving in a giant wheel  
(b) a driver in a sports car moving with a constant high speed of  $200 \text{ kmh}^{-1}$  on a straight road  
(c) the pilot of an aeroplane which is taking off  
(d) a cyclist negotiating a sharp curve. [IPUEE 07]

29. A man of mass 60 kg and a boy of mass 30 kg are standing together on frictionless ice surface. If they push each other apart, the man moves away with a speed of 0.4 m/s relative to ice. After 5 s they will be away from each other at a distance of

- (a) 9.0 m (b) 3.0 m  
(c) 6.0 m (d) 30 m [DCE 08]

30. A batsman deflects a ball by an angle of  $45^\circ$  without changing its initial speed which is equal to  $50 \text{ kmh}^{-1}$ . Mass of the ball is 0.15 kg. What is the impulse imparted to the ball ?

- (a)  $4.2 \text{ kg ms}^{-1}$  in the direction of the final velocity  
(b)  $4.2 \text{ kg ms}^{-1}$  in the direction of the initial velocity  
(c)  $4.2 \text{ kg ms}^{-1}$  in the direction opposite the initial velocity  
(d)  $4.2 \text{ kg ms}^{-1}$  in the direction along the bisector of the initial and final directions of the velocity. [DCE 08]

31. A satellite in a force-free space sweeps stationary interplanetary dust at the rate  $\frac{dM}{dt} = \beta v$ . The acceleration of the satellite is

- (a)  $-\beta v^2 / M$                       (b)  $-\beta v^2 / 2M$   
 (c)  $-\beta v^2$                               (d)  $-M\beta / v^2$ .

[DCE 08]

32. A car when passes through a bridge exerts a force on it which is equal to

- (a)  $Mg + \frac{Mv^2}{r}$                       (b)  $\frac{Mv^2}{r}$   
 (c)  $Mg - \frac{Mv^2}{r}$                       (d) none of these.

[DCE 08]

33. Two wires AC and BC are tied to a small sphere C of mass 5 kg, which revolved at a constant speed  $v$  in the horizontal circle of radius 1.6 m. The minimum value of  $v$  is

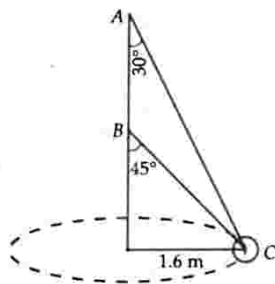

- (a)  $3.01 \text{ ms}^{-1}$                       (b)  $4.01 \text{ ms}^{-1}$   
 (c)  $8.2 \text{ ms}^{-1}$                       (d)  $3.96 \text{ ms}^{-1}$

[DCE 08]

34. A lift is moving upward with increasing speed with acceleration  $a$ .

The apparent weight will be

- (a) less than the actual weight  
 (b) more than the actual weight and have a fixed value.  
 (c) more than the actual weight which increases as long as velocity increases.  
 (d) zero.

35. A block of mass  $M$  at the end of a string is whirled round a vertical circle of radius  $R$ . The critical speed of the block at the top of the swing is

- (a)  $(R/g)^{1/2}$                       (b)  $g/R$   
 (c)  $M/Rg$                           (d)  $(Rg)^{1/2}$

[DCE 09]

## Answers and Explanations

1. (c) [Action] = [Force] = [MLT<sup>-2</sup>]

2. (b)  $R = \sqrt{5^2 + 5^2} = 5\sqrt{2}$

$$\tan \phi = \frac{5 \sin 90^\circ}{5 + 5 \cos 90^\circ} = \frac{5}{5} = 1$$

$\therefore \phi = \frac{\pi}{4}$

3. (b)  $R^2 = P^2 + Q^2 + 2PQ \cos \theta$

$$2^2 = 2^2 + 2^2 + 2 \times 2 \times 2 \cos \theta$$

$$\cos \theta = -\frac{1}{2} \text{ or } \theta = 120^\circ.$$

4. (a) Only in option (a),  $\vec{F}_1$  and  $\vec{F}_2$  can add up in same order to give  $\vec{F}_3$  in opposite order.

5. (a)  $F = ma = m \frac{dv}{dt} = m \frac{dv}{dx} \cdot \frac{dx}{dt}$

$$F dx = mv dv \quad \left[ \frac{dx}{dt} = v \right]$$

$$3x dx = 8v dv$$

$$3 \int_2^{10} x dx = 8 \int_0^v v dv$$

$$\frac{3}{2} [x^2]_2^{10} = \frac{8}{2} [v^2]_0^v$$

$$\frac{3}{2} [100 - 4] = 4 [v^2 - 0]$$

or  $\frac{3}{2} \times \frac{94}{4} = v^2$  or  $v = 6 \text{ m/s}$ .

6. (c)  $\vec{u} = (30\hat{i} + 40\hat{j}) \text{ m/s}$

$\therefore u_y = 40 \text{ m/s}$

$$\vec{F} = (-6\hat{i} - 5\hat{j}) \text{ N}$$

$\therefore F_y = -5 \text{ N}$

$$a_y = \frac{F_y}{m} = \frac{-5}{5} = -1 \text{ m/s}^2$$

$$v_y = 0$$

But  $v_y = u_y + a_y t$

$\therefore 0 = 40 - 1 \times t$  or  $t = 40 \text{ s}$ .

5.112 PHYSICS-XI

7. (d) The force applied by the student into himself is an internal force. According to Newton's laws, only an external force can change the state of motion of an object.

$$8. (b) a = \frac{F}{m_1 + m_2 + m_3} = \frac{28 \text{ N}}{(4+2+1)\text{kg}} = 4 \text{ ms}^{-2}.$$

$$9. (c) a = \frac{10}{2+3+5} = 1 \text{ ms}^{-2}$$

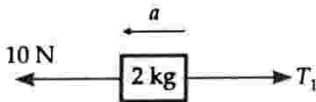

By Newton's second law,

$$2a = 10 - T_1$$

$$T_1 = 10 - 2a$$

$$= 10 - 2 \times 1 = 8 \text{ N}.$$

$$10. (c) a = \frac{m_1 - m_2}{m_1 + m_2} g$$

$$g = \frac{10-6}{10+6} \times 10$$

$$= 2.5 \text{ ms}^{-2}.$$

11. (d) Let  $T_1$  and  $T_2$  be the tensions in sections BC and BF respectively.

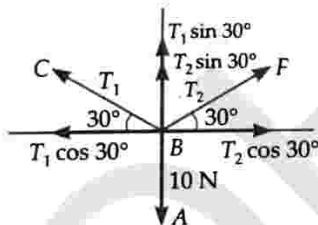

$$T_1 \cos 30^\circ = T_2 \cos 30^\circ$$

$$\Rightarrow T_1 = T_2$$

Also,  $T_1 \sin 30^\circ + T_2 \sin 30^\circ = 10$

$$2T_1 \sin 30^\circ = 10$$

$$2T_1 \times \frac{1}{2} = 10$$

or  $T_1 = T_2 = 10 \text{ N}.$

12. (a) Refer to the solution of Problem 10 on page 5.113.

$$13. (b) [\text{Impulse}] = [\text{Change in momentum}] \\ = [\text{MLT}^{-1}]$$

14. (b) Impulse = Change in momentum

15. (b) Change in momentum

$$= mv - (-mv) = 2mv.$$

$$16. (d) mv = MV$$

$$v = \frac{MV}{m} = \frac{1 \times 5}{0.01} = 500 \text{ ms}^{-1}.$$

17. (c) Measured weight =  $m(g+a)$ . It is more than actual weight ( $mg$ ).

18. (b) In a lift falling under gravity,  $g=0$

$$T = 2\pi \sqrt{\frac{l}{g}} = \infty$$

19. (d) Velocity of light is same in all inertial frames.

20. (b) According to theory of relativity,

$$m = \frac{m_0}{\sqrt{1 - \frac{v^2}{c^2}}}$$

$$2m_0 = \frac{m_0}{\sqrt{1 - \frac{v^2}{c^2}}}$$

$$1 - \frac{v^2}{c^2} = \left(\frac{1}{2}\right)^2 = \frac{1}{4}$$

$$\frac{v^2}{c^2} = 1 - \frac{1}{4} = \frac{3}{4}$$

$$v = \frac{\sqrt{3}}{2} c = \frac{1.732 \times 3 \times 10^8}{2} \text{ ms}^{-1}$$

$$= 2.59 \times 10^8 \text{ ms}^{-1}.$$

$$21. (c) m = \frac{m_0}{\sqrt{1 - \frac{v^2}{c^2}}} = \frac{m_0}{\sqrt{1 - \frac{3}{4} \cdot \frac{1}{c^2}}}$$

$$= 2m_0.$$

$$22. (b) f = mg = 2 \times 10 = 20 \text{ N}.$$

23. (c)

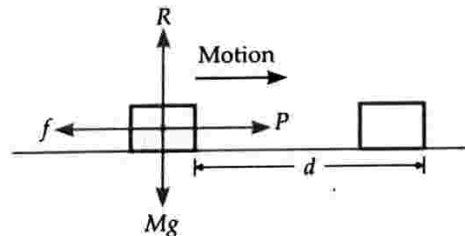

To move the block with acceleration, the applied force

$$P = f + \mu R$$

$$\therefore W = P \times d = \mu R d.$$

24. (a) According to Newton's second law,

$$ma = f_k - mg \sin \theta = \mu_k R - mg \sin \theta \\ = \mu_k \cdot mg \cos \theta - mg \sin \theta$$

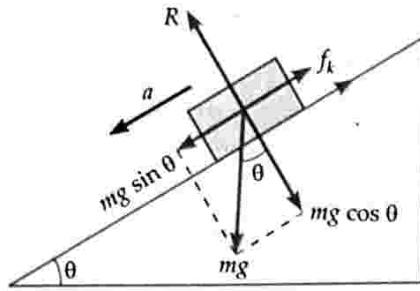

$$\begin{aligned} \therefore a &= g(\mu_k \cos \theta - \sin \theta) \\ &= g\left(\frac{1}{\sqrt{3}} \cos 30^\circ - \sin 30^\circ\right) \\ &= g\left(\frac{1}{\sqrt{3}} \cdot \frac{\sqrt{3}}{2} - \frac{1}{2}\right) = 0. \end{aligned}$$

25. (a) The object will slip if centripetal force  $\geq$  force of friction

$$\begin{aligned} m r \omega^2 &\geq \mu m g \\ r \omega^2 &\geq \mu g \\ r \omega^2 &= \text{constant} \\ \frac{r_1}{r_2} &= \left(\frac{\omega_2}{\omega_1}\right)^2 \\ \frac{4 \text{ cm}}{r_2} &= \left(\frac{2\omega}{\omega}\right)^2 \quad \text{or} \quad r_2 = 1 \text{ cm}. \end{aligned}$$

26. (b)  $T = \frac{mv^2}{r} + mg \cos \theta$

$$\begin{aligned} \therefore T &\propto \cos \theta \\ \frac{T_1}{T_2} &= \frac{\cos 30^\circ}{\cos 60^\circ} = \frac{\sqrt{3}/2}{1/2} = \frac{\sqrt{3}}{1} \quad \text{or} \quad T_1 > T_2. \end{aligned}$$

27. (b) Velocity of light is maximum in vacuum.

28. (c) An inertial frame is a non-accelerated frame. Hence only option (b) is correct.

29. (c) The man and the boy move in opposite directions.

$$\begin{aligned} \text{Momentum of man} &= -\text{Momentum of boy} \\ 60 \times 0.4 &= -30 \times v \end{aligned}$$

$\therefore$  Velocity of the boy,

$$v = -0.8 \text{ ms}^{-1}$$

$$\text{Relative velocity} = 0.4 + 0.8 = 1.2 \text{ ms}^{-1}$$

$$\begin{aligned} \text{Distance between man and boy after 5 s} \\ &= 1.2 \times 5 = 6.0 \text{ m}. \end{aligned}$$

30. (d) Refer answer to NCERT Exercise 5.20 on page 5.78.

31. (a) Thrust,  $F = -v \frac{dM}{dt} = -v \cdot \beta v = -\beta v^2$

$$\text{Acceleration, } a = \frac{F}{M} = -\frac{\beta v^2}{M}$$

32. (c)  $F = Mg - \frac{Mv^2}{r}$

33. (d) Free body for the sphere is shown in the figure.

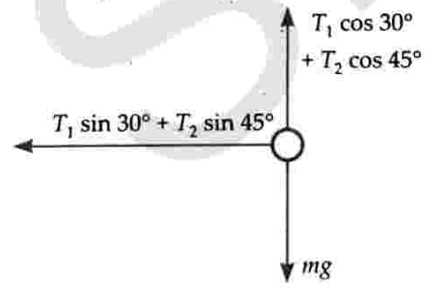

$$T_1 \cos 30^\circ + T_2 \cos 45^\circ = mg \quad \dots(1)$$

$$T_1 \sin 30^\circ + T_2 \sin 45^\circ = \frac{mv^2}{r} \quad \dots(2)$$

On solving (1) and (2), we get

$$T_1 = \frac{mg - \frac{mv^2}{r}}{2}$$

But  $T_1 > 0$

$$\therefore mg > \frac{mv^2}{r} \quad \text{or} \quad v < \sqrt{rg}$$

$$\therefore v_{\text{max}} = \sqrt{rg} = \sqrt{1.6 \times 9.8} = 3.9 \text{ ms}^{-1}$$

34. (b)  $R = m(g + a)$ .

35. (d) At the top of the swing,  $v_c = \sqrt{Rg}$ .

## AIIMS Entrance Exam

1. In the figure given, the position-time graph of a particle of mass 0.1 kg is shown.

The impulse at  $t = 2$  s is

(a)  $0.2 \text{ kg ms}^{-1}$

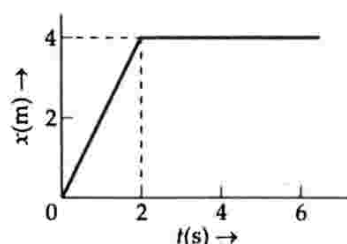

(b)  $-0.2 \text{ kg ms}^{-1}$

(c)  $0.1 \text{ kg ms}^{-1}$

(d)  $-0.4 \text{ kg ms}^{-1}$

[AIIMS 05]

2. A gun fires a bullet of mass 50 g with a velocity of  $30 \text{ ms}^{-1}$ . Because of this, the gun is pushed back with a velocity of  $1 \text{ ms}^{-1}$ . The mass of the gun is

(a) 5.5 kg

(b) 3.5 kg

(c) 1.5 kg

(d) 0.5 kg

[AIIMS 2K]

3. A body of mass  $M$  moving with velocity  $V$  explodes into two equal parts. If one comes to rest and the other body moves with velocity  $v$ , what would be the value of  $v$  ?

- (a)  $v$  (b)  $v/\sqrt{2}$   
 (c)  $4v$  (d)  $2v$  [AIIMS ]

4. Rocket engines lift a rocket from the earth surface, because hot gases with high velocity

- (a) push against the air  
 (b) push against the earth  
 (c) react against the rocket and push it up  
 (d) heat up the air which lifts the rocket. [AIIMS 98]

5. The motion of a rocket is based on the principle of conservation of

- (a) linear momentum (b) angular momentum  
 (c) kinetic energy (d) mass [AIIMS 95]

6. A bullet is fired from a rifle. If the rifle recoils freely, then the kinetic energy of the rifle is

- (a) less than that of the bullet  
 (b) more than that of the bullet  
 (c) same as that of the bullet  
 (d) equal or less than that of the bullet. [AIIMS 90]

7. A person is standing in an elevator. In which situation he finds his weight less ?

- (a) When the elevator moves upward with constant acceleration  
 (b) When the elevator moves downward with constant acceleration  
 (c) When the elevator moves upward with uniform velocity  
 (d) When the elevator moves downward with uniform velocity. [AIIMS 05]

8. If a person with a spring balance and a body hanging from it goes up and up in an aeroplane, then the reading of the weight of the body as indicated by the spring balance, will

- (a) go on increasing (b) go on decreasing  
 (c) first increase and then decrease  
 (d) remain the same. [AIIMS 98]

9. A man of mass 60 kg records his weight on a weighing machine placed inside a lift. The ratio of the weights of man recorded when lift is ascending up with a uniform speed of 2 m/s to when it is descending down with a uniform speed of 4 m/s will be

- (a) 0.5 (b) 1  
 (c) 2 (d) none of the above. [AIIMS 07]

10. A simple pendulum is set up in a trolley which is moving with an acceleration  $a$  on a horizontal plane. Then the thread of the pendulum in the mean position makes an angle with the vertical equal to

- (a)  $\tan^{-1}(a/g)$  in the forward direction  
 (b)  $\tan^{-1}(a/g)$  in the backward direction  
 (c)  $\tan^{-1}(g/a)$  in the forward direction  
 (d)  $\tan^{-1}(g/a)$  in the backward direction. [AIIMS 00]

11. The forces, which meet at one point but their lines of action do not lie in one plane, are called

- (a) coplanar concurrent forces  
 (b) coplanar non-concurrent forces  
 (c) non-coplanar concurrent forces  
 (d) non-coplanar non-concurrent forces. [AIIMS 96]

12. Which of the following is non-conservative force ?

- (a) Interatomic force (b) Gravitational force  
 (c) Electrostatic force (d) Viscous force [AIIMS 96]

13. A person used force ( $F$ ), shown in figure to move a load with constant velocity on a surface. Identify the correct surface profile ( $A$ ).

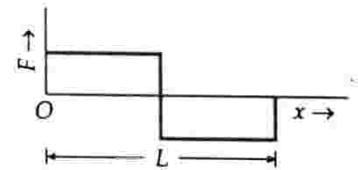

- (a) (b)   
 (c) (d)

[AIIMS 06]

14. A particle revolves round a circular path. The acceleration of the particle is inversely proportional to

- (a) radius (b) velocity  
 (c) mass of particle (d) both (b) and (c)

[AIIMS 94]

15. If the radii of circular paths of two particles of same masses are in the ratio of 1 : 2, then to have a constant centripetal force, their velocities should be in a ratio of

- (a)  $1:\sqrt{2}$  (b)  $\sqrt{2}:1$   
 (c) 4 : 1 (d) 1 : 4 [AIIMS 96]



16. A stone tied to a string is rotated with a uniform speed in a vertical plane. If mass of the stone is  $m$ , length of the string is  $r$  and linear speed of the stone is  $v$ , then tension in the string, when the stone is at its lowest point, ( $g$  = acceleration due to gravity) is

- (a)  $mg$  (b)  $\frac{mv^2}{r}$   
 (c)  $\frac{mv^2}{r} - mg$  (d)  $\frac{mv^2}{r} + mg$  [AIIMS 01]

17. A body is allowed to slide down a frictionless track freely under gravity. The track ends in a semicircular shaped part of diameter  $D$ . What should be the height (minimum) from which the body must fall, so that it completes the circle ?

- (a)  $4D/5$  (b)  $5D/4$   
 (c)  $D$  (d)  $2D$  [AIIMS 2K]

18. If the normal force is doubled, then coefficient of friction is

- (a) halved (b) tripled  
 (c) doubled (d) not changed [AIIMS 94]

19. A body of mass  $m$  is placed on a rough surface with coefficient of friction  $\mu$  inclined at  $\theta$ . If the mass is in equilibrium, then

- (a)  $\theta = \tan^{-1} \mu$  (b)  $\theta = \tan^{-1} \frac{1}{\mu}$   
 (c)  $\theta = \tan^{-1} \frac{m}{\mu}$  (d)  $\theta = \tan^{-1} \frac{\mu}{m}$  [AIIMS 96, 99, DPMT 97]

20. Two masses  $M_1 = 5$  kg and  $M_2 = 10$  kg are connected at the ends of an inextensible string passing over a frictionless pulley as shown. When the masses are released, then the acceleration of the masses will be

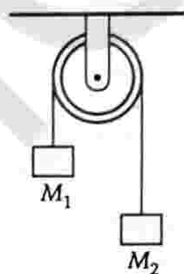

- (a)  $g$  (b)  $g/2$   
 (c)  $g/3$  (d)  $g/4$  [AIIMS 2010]

21. Three equal weights of 3 kg each are hanging on a string passing over a frictionless pulley as shown in the figure. The tension in the string between masses II and III will be (Take  $g = 10 \text{ m/s}^2$ )

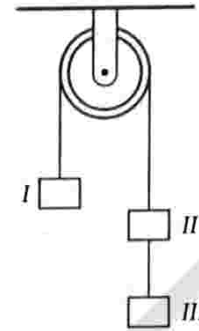

- (a) 5 N (b) 6 N  
 (c) 10 N (d) 20 N [AIIMS 2009]

22. A block of mass  $m$  is pulled along a horizontal surface by applying a force at an angle  $\theta$  with the horizontal. If the block travels with a uniform velocity and has a displacement  $d$  and the coefficient of friction is  $\mu$ , then the work done by the applied force is

- (a)  $\frac{\mu mgd}{\cos \theta + \mu \sin \theta}$  (b)  $\frac{\mu mgd \cos \theta}{\cos \theta + \mu \sin \theta}$   
 (c)  $\frac{\mu mgd \sin \theta}{\cos \theta + \mu \sin \theta}$  (d)  $\frac{\mu mgd \cos \theta}{\cos \theta - \mu \sin \theta}$  [AIIMS 2010]

#### ASSERTIONS AND REASONS

**Directions.** In the following questions, a statement of assertion is followed by a statement of reason. Mark the correct choice as

- (a) If both assertion and reason are true and reason is the correct explanation of the assertion.  
 (b) If both assertion and reason are true but reason is not correct explanation of the assertion.  
 (c) If assertion is true, but reason is false.  
 (d) If both assertion and reason are false.

23. **Assertion.** A rocket moves forward by pushing the surrounding air backwards.

**Reason.** It derives the necessary thrust to move forward, according to Newton's third law of motion. [AIIMS 01]

24. **Assertion.** Frictional forces are conservative forces.

**Reason.** Potential energy can be associated with frictional forces. [AIIMS 05]

25. **Assertion.** The driver in a vehicle moving with a constant speed on a straight road is a non-inertial frame of reference.

**Reason.** A reference frame, in which Newton's laws of motion are applicable, is non-inertial. [AIIMS 04]

26. **Assertion.** A man in a closed cabin, which is falling freely, does not experience gravity.

**Reason.** Inertial and gravitational masses have equivalence. [AIIMS 06]

27. **Assertion.** It is difficult to move a cycle along the road with its brakes on.

**Reason.** Sliding friction is greater than rolling friction. [AIIMS 02]

28. **Assertion.** On a rainy day, it is difficult to drive a car or bus at high speed.

**Reason.** The value of coefficient of friction is lowered due to wetting of the surface. [AIIMS 95, 99]

29. **Assertion.** Use of ball bearings between two moving parts of a machine is a common practice.

**Reason.** Ball bearings reduce vibrations and provide good stability. [AIIMS 06]

30. **Assertion.** During turning, a cyclist leans towards the centre of the curve; while a man sitting in the car leans outwards of the curve.

**Reason.** An acceleration is acting towards the centre of the curve. [AIIMS 97]

31. **Assertion.** The apparent weight of a body in an elevator moving with some downward acceleration is less than the actual weight of a body.

**Reason.** The part of the weight is spent in producing downward acceleration, when body is in elevator. [AIIMS 2010]

32. **Assertion.** Impulsive force is large and acts for a short time.

**Reason.** Finite change in momentum should be produced by the force. [AIIMS 2009]

33. **Assertion.** A horse has to pull a cart harder during the first few steps of his motion.

**Reason.** The first few steps are always difficult. [AIIMS 2010]

## Answers and Explanations

1. (b) Before  $t = 2$  s, the particle has a constant velocity,

$$u = \frac{4-0}{2-0} = 2 \text{ ms}^{-1}$$

After  $t = 2$ , the particle is at rest, so  $v = 0$ .

$$\begin{aligned} \text{Impulse} &= m(v-u) = 0.1(0-2) \\ &= -0.2 \text{ kg ms}^{-1}. \end{aligned}$$

2. (c) By conservation of momentum

$$\begin{aligned} MV &= mv \\ M &= \frac{mv}{V} = \frac{0.05 \times 30}{1} = 1.5 \text{ kg}. \end{aligned}$$

3. (d)



By conservation of momentum,

$$MV = \frac{M}{2} \times 0 + \frac{M}{2} \times v$$

or  $v = 2V$ .

4. (c) Hot gases with high velocity react against the rocket and push it up.

5. (a) A rocket works on the principle of conservation of linear momentum.

6. (a) By conservation of momentum,

$$MV = mv$$

or  $V = \frac{mv}{M}$

Kinetic energy of the rifle is

$$\begin{aligned} K_r &= \frac{1}{2} MV^2 = \frac{1}{2} M \frac{m^2 v^2}{M^2} \\ &= \frac{m}{M} \cdot \frac{1}{2} mv^2 = \frac{m}{M} K_b \end{aligned}$$

As  $m < M$ ,  $K_r < K_b$

Thus the K.E. of the rifle is less than that of the bullet.

7. (b) When the elevator moves downward with acceleration  $a$ , the apparent weight,

$$W' = m(g-a) < W (= mg)$$

8. (b) As the person goes up above the earth's surface, the value of 'g' decreases. Hence the reading in the spring balance will go on decreasing.

9. (b) Uniform speed does not affect the weight of man.

$$\text{Required ratio} = \frac{60 \text{ kg wt}}{60 \text{ kg wt}} = 1.$$

10. (b)

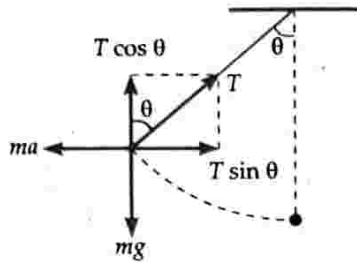

A backward force equal to  $ma$  acts on the bob. In the equilibrium position,

$$T \sin \theta = ma$$

$$T \cos \theta = mg$$

$$\therefore \tan \theta = \frac{T \sin \theta}{T \cos \theta} = \frac{ma}{mg} = \frac{a}{g}$$

$$\text{or } \theta = \tan^{-1} \left( \frac{a}{g} \right)$$

11. (c) Non-coplanar and concurrent forces.

12. (d) Viscous force is a non-conservative force.

13. (c) Initial force is applied to overcome static friction.

Applied force &gt; Limiting friction

$$\text{or } F > \mu_s R$$

Body has constant acceleration and its velocity increases proportionately with time. Then suddenly the force is decreased to just balance the kinetic friction ( $\mu_k R$ ). Then the body continues to move with the constant maximum velocity attained by it earlier.

$$14. (a) a = \frac{v^2}{r} \quad \text{i.e., } a \propto \frac{1}{r}$$

$$15. (a) \text{ Centripetal force, } F = \frac{mv^2}{r}$$

$$\therefore v = \sqrt{\frac{Fr}{m}}$$

For same  $F$  and  $m$ ,  $v \propto \sqrt{r}$ .

$$\therefore \frac{v_1}{v_2} = \sqrt{\frac{r_1}{r_2}} = \sqrt{\frac{1}{2}} = 1 : \sqrt{2}$$

$$16. (d) T_L = \frac{mv^2}{r} + mg$$

For derivation, refer answer to Q. 70 on page 5.58.

17. (b) The body will complete the vertical circle if its minimum speed at the bottom is  $\sqrt{5gR}$ , where  $R$  is the radius of the circular track. If the body falls through height  $h$ ,

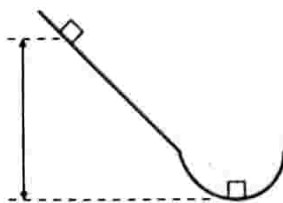

or

$$\therefore f = \mu R = \mu (mg - F \sin \theta)$$

$$\text{then } \sqrt{2gh} = \sqrt{5g \frac{D}{2}}$$

$$\text{or } h = \frac{5D}{4}$$

18. (c) Coefficient of friction is independent of normal force.

19. (a)

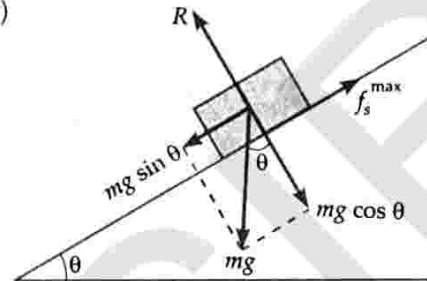

For equilibrium of the body,

$$mg \sin \theta = f_s^{\max}$$

$$mg \cos \theta = R$$

$$\therefore \frac{mg \sin \theta}{mg \cos \theta} = \frac{f_s^{\max}}{R}$$

$$\text{or } \tan \theta = \mu$$

$$\text{or } \theta = \tan^{-1}(\mu)$$

$$20. (c) a = \frac{M_2 - M_1}{M_2 + M_1} g = \frac{10 - 5}{10 + 5} \times g = \frac{g}{3}$$

$$21. (d) T_1 - mg = ma$$

$$2mg - T_1 = 2ma$$

$$mg - T_2 = ma$$

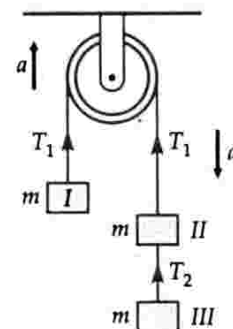

$$\text{On solving, } T_2 = \frac{2}{3} mg = \frac{2}{3} \times 3 \times 10 = 20 \text{ N}$$

22. (b) As the block moves with a uniform velocity, the resultant force on it is zero.

$$R + F \sin \theta = mg$$

$$R = mg - F \sin \theta$$

$$\therefore f = \mu R = \mu (mg - F \sin \theta)$$

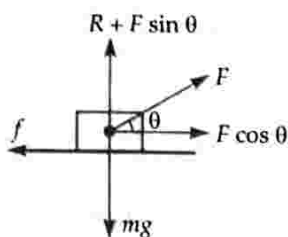

Also,  $F \cos \theta = f$   
 or  $F \cos \theta = \mu (mg - F \sin \theta)$   
 or  $F(\cos \theta + \mu \sin \theta) = \mu mg$   
 or  $F = \frac{\mu mg}{\cos \theta + \mu \sin \theta}$   
 $\therefore W = F d \cos \theta = \frac{\mu mgd \cos \theta}{\cos \theta + \mu \sin \theta}$

23. (a) Both the assertion and reason are true.  
 24. (d) Both the assertion and reason are false.  
 25. (c) The assertion is true and reason is false.  
 26. (c) Both the assertion and reason are true but reason is not correct explanation of the assertion.  
 27. (a) With brakes on, a cycle can slide and not roll. Both the assertion and reason are true.

28. (a) Both assertion and reason are true. Due to wetting, friction decreases between tyres and road. This may lead to skidding of the vehicle.

29. (c) The assertion is true but the reason is false. The ball bearings reduce friction by converting sliding friction into rolling friction.

30. (c) The assertion is true but reason is false. The cyclist leans inward to get necessary centripetal force. So an acceleration acts towards the centre of the curve. The man sitting in the car leans outwards due to the centrifugal force acting on him. The acceleration acts on him away from the centre of the curve.

31. (b) Assertion is true but the reason is not its correct explanation.

Apparent weight =  $m(g - a)$ .

32. (a) Assertion is true, the reason is its correct explanation.

33. (c) During the first few steps of his motion, the horse has to work against the limiting friction and once the cart starts moving, the horse has to work against kinetic friction which is less than the limiting friction.

### CBSE PMT Prelims and Final Exams

1. A 10 N force is applied on a body to produce in it an acceleration of  $1 \text{ m/s}^2$ .

The mass of the body is

- (a) 15 kg (b) 20 kg  
 (c) 10 kg (d) 5 kg [CBSE PMT 96]

2. A cricketer catches a ball of mass 150 g in 0.1 s moving with speed 20 m/s. Then he experiences a force of

- (a) 300 N (b) 30 N  
 (c) 3 N (d) 0.3 N [CBSE PMT 01]

3. A force of 6 N acts on a body at rest and of mass 1 kg. During this time, the body attains a velocity of 30 m/s. The time for which the force acts on the body is

- (a) 7 seconds (b) 5 seconds  
 (c) 10 seconds (d) 8 seconds [CBSE PMT 97]

4. Physical independence of force is a consequence of

- (a) third law of motion  
 (b) second law of motion  
 (c) first law of motion  
 (d) all of these laws [CBSE PMT 91]

5. A force vector applied on a mass is represented as  $\vec{F} = 6\hat{i} - 8\hat{j} + 10\hat{k}$  and accelerates with  $1 \text{ m/s}^2$ . What will be the mass of the body?

- (a) 10 kg (b) 20 kg  
 (c)  $10\sqrt{2}$  kg (d)  $2\sqrt{10}$  kg [CBSE PMT 96, 09]

6. A ball is dropped from a spacecraft revolving the earth at a height of 120 km. What will happen to the ball?

- (a) It will continue to move with the same speed along the original orbit of spacecraft.  
 (b) It will move with the same speed, tangentially to the spacecraft.  
 (c) It will fall down to the earth gradually.  
 (d) It will go very far in the space. [CBSE PMT 96]

7. An object of mass 3 kg is at rest. Now a force of  $\vec{F} = 6t^2\hat{i} + 4t\hat{j}$  is applied on the object. Then velocity of object at  $t = 3$  is

- (a)  $18\hat{i} + 3\hat{j}$  (b)  $18\hat{i} + 6\hat{j}$   
 (c)  $3\hat{i} + 18\hat{j}$  (d)  $18\hat{i} + 4\hat{j}$  [CBSE PMT 02]

8. Sand is being dropped from a conveyer belt at the rate of  $M$  kg/s. The force necessary to keep the belt moving with a constant velocity of  $v$  m/s will be

- (a)  $Mv$  newton (b)  $2Mv$  newton  
(c)  $\frac{Mv}{2}$  newton (d) zero [CBSE PMT 08]

9. Three forces acting on a body are shown in the figure. To have the resultant force only along the

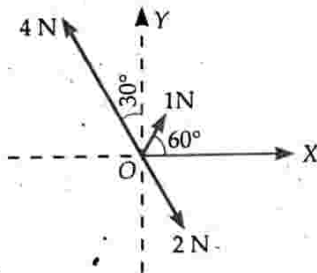

$y$ -direction, the magnitude of the minimum additional force needed along  $OX$  is

- (a) 0.5 N (b) 1.5 N  
(c)  $\sqrt{3}/4$  N (d)  $\sqrt{3}$  N [CBSE PMT 08]

10. A particle of mass  $m$  is projected with velocity  $v$  making an angle of  $45^\circ$  with the horizontal. When the particle lands on the level ground, the magnitude of the change in its momentum will be

- (a)  $2mv$  (b)  $mv/\sqrt{2}$   
(c)  $\sqrt{2}mv$  (d) zero [CBSE PMT 08]

11. A particle of mass  $m$  is moving a uniform velocity  $v_1$ . It is given an impulse such that its velocity becomes  $v_2$ . The impulse is equal to

- (a)  $m[|v_2| - |v_1|]$  (b)  $\frac{1}{2}m[v_2^2 - v_1^2]$   
(c)  $m[v_1 + v_2]$  (d)  $m[v_2 - v_1]$  [CBSE PMT 90]

12. A bullet is fired from a gun. The force on the bullet is given by

$$F = 600 - 2 \times 10^5 t$$

where  $F$  is in newton and  $t$  in seconds. The force on the bullet becomes zero as soon as it leaves the barrel. What is the average impulse imparted to the bullet?

- (a) 9 Ns (b) zero  
(c) 1.8 Ns (d) 0.9 Ns [CBSE PMT 98]

13. A body of mass 3 kg hits a wall at an angle of  $60^\circ$  and returns at the same angle. The impact time was 0.2 sec. The force exerted on the wall,

- (a)  $150\sqrt{3}$  N (b)  $50\sqrt{3}$  N  
(c) 100 N (d)  $75\sqrt{3}$  N [CBSE PMT 2K]

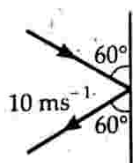

14. A 0.5 kg ball moving with a speed of 12 m/s strikes a hard wall at an angle of  $30^\circ$  with the wall. It is reflected with the same speed at the same angle. If the ball is in contact with the wall for 0.25 second, the average force acting on the wall is

- (a) 96 N (b) 48 N  
(c) 24 N (d) 12 N [CBSE PMT 06]

15. A lift of mass 1000 kg is moving with an acceleration of  $1 \text{ m/s}^2$  in upward direction, then the tension developed in the string which is connected to lift is

- (a) 9800 N (b) 10,800 N  
(c) 11,000 N (d) 10,000 N [CBSE PMT 02]

16. A mass of 1 kg is suspended by a thread. It is

- (i) lifted up with an acceleration  $4.9 \text{ m/s}^2$   
(ii) lowered with an acceleration  $4.9 \text{ m/s}^2$

The ratio of the tensions is

- (a) 1 : 3 (b) 1 : 2  
(c) 3 : 1 (d) 2 : 1 [CBSE PMT 98]

17. A man weighs 80 kg. He stands on a weighing scale in a lift which is moving upwards with a uniform acceleration of  $5 \text{ m/s}^2$ . What would be the reading on the scale? ( $g = 10 \text{ m/s}^2$ )

- (a) zero (b) 400 N  
(c) 800 N (d) 1200 N [CBSE PMT 03]

18. A monkey of mass 20 kg is holding a vertical rope. The rope will not break when a mass of 25 kg is suspended from it but will break if the mass exceeds 25 kg. What is the maximum acceleration with which the monkey can climb up along the rope? ( $g = 10 \text{ m/s}^2$ )

- (a)  $5 \text{ m/s}^2$  (b)  $10 \text{ m/s}^2$   
(c)  $25 \text{ m/s}^2$  (d)  $2.5 \text{ m/s}^2$  [CBSE PMT 03]

19. A monkey is descending from the branch of a tree with constant acceleration. If the breaking strength is 75% of the weight of the monkey, the minimum acceleration with which monkey can slide down without breaking branch is

- (a)  $g$  (b)  $\frac{3g}{4}$  (c)  $\frac{g}{4}$  (d)  $\frac{g}{2}$

[CBSE PMT 93]

20. Two masses as shown in the figure are suspended from a massless pulley. The acceleration of the system when masses are left free is

- (a)  $\frac{2g}{3}$  (b)  $\frac{g}{3}$   
(c)  $\frac{g}{9}$  (d)  $\frac{g}{7}$  [CBSE PMT 2K]

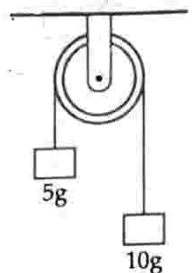

21. A man fires a bullet of mass 200 g at a speed of 5 m/s. The gun is of one kg mass. By what velocity the gun rebounds backward ?

- (a) 1 m/s (b) 0.01 m/s  
(c) 0.1 m/s (d) 10 m/s [CBSE PMT 96]

22. A 1 kg stationary bomb is exploded in three parts having mass 1 : 1 : 3 respectively. Parts having same mass move in perpendicular direction with velocity 30 m/s, then the velocity of bigger part will be

- (a)  $10\sqrt{2}$  m/sec (b)  $\frac{10}{\sqrt{2}}$  m/sec  
(c)  $15\sqrt{2}$  m/sec (d)  $\frac{15}{\sqrt{2}}$  m/sec [CBSE PMT 01]

23. A body of mass 5 kg explodes at rest into three fragments with masses in the ratio 1 : 1 : 3. The fragments with equal masses fly in mutually perpendicular directions with speeds of 21 m/s. The velocity of heaviest fragment in m/s will be

- (a)  $7\sqrt{2}$  (b)  $5\sqrt{2}$   
(c)  $3\sqrt{2}$  (d)  $\sqrt{2}$  [CBSE PMT 89]

24. In a rocket, fuel burns at the rate of 1 kg/s. This fuel is ejected from the rocket with a velocity of 60 km/s. This exerts a force on the rocket equal to

- (a) 6000 N (b) 60000 N  
(c) 60 N (d) 600 N [CBSE PMT 94]

25. If the force on a rocket, moving with a velocity of 300 m/s is 210 N, then the rate of combustion of the fuel is

- (a) 0.07 kg/s (b) 1.4 kg/s  
(c) 0.7 kg/s (d) 10.7 kg/s [CBSE PMT 99]

26. A 600 kg rocket is set for a vertical firing. If the exhaust speed is  $1000 \text{ ms}^{-1}$ , the mass of the gas ejected per second to supply the thrust needed to overcome the weight of rocket is

- (a)  $117.6 \text{ kgs}^{-1}$  (b)  $58.6 \text{ kgs}^{-1}$   
(c)  $6 \text{ kgs}^{-1}$  (d)  $76.4 \text{ kgs}^{-1}$  [CBSE PMT 90]

27. A 5000 kg rocket is set for vertical firing. The exhaust speed is  $800 \text{ ms}^{-1}$ . To give an inertial upward acceleration of  $20 \text{ ms}^{-2}$ , the amount of gas ejected per second to supply the needed thrust will be ( $g = 10 \text{ ms}^{-2}$ )

- (a)  $185.5 \text{ kgs}^{-1}$  (b)  $187.5 \text{ kgs}^{-1}$   
(c)  $127.5 \text{ kgs}^{-1}$  (d)  $137.5 \text{ kgs}^{-1}$  [CBSE PMT 98]

28. A block of mass 10 kg is placed on rough horizontal surface having coefficient of friction  $\mu = 0.5$ .

If a horizontal force of 100 N is acting on it, then acceleration of the block will be

- (a)  $10 \text{ m/s}^2$  (b)  $5 \text{ m/s}^2$   
(c)  $15 \text{ m/s}^2$  (d)  $0.5 \text{ m/s}^2$  [CBSE PMT 02]

29. On the horizontal surface of a truck a block of mass 1 kg is placed ( $\mu = 0.6$ ) and truck is moving with acceleration  $5 \text{ m/sec}^2$ , then the frictional force on the block will be

- (a) 5 N (b) 6 N  
(c) 5.88 N (d) 8 N [CBSE PMT 01]

30. Consider a car moving along a straight horizontal road with a speed of 72 km/h. If the coefficient of static friction between the tyres and the road is 0.5, the shortest distance in which the car can be stopped (taking  $g = 10 \text{ m/s}^2$ ) is

- (a) 30 m (b) 40 m  
(c) 72 m (d) 20 m [CBSE PMT 92]

31. A heavy uniform chain lies on horizontal table top. If the coefficient of friction between the chain and the table surface is 0.25, then the maximum fraction of the length of the chain that can hang over one edge of the table is

- (a) 20% (b) 25%  
(c) 35% (d) 15% [CBSE PMT 91]

32. A block B is pushed momentarily along a horizontal surface with an initial velocity  $v$ . If  $\mu$  is the coefficient of sliding friction between B and the surface, block B will come to rest after a time

- (a)  $g\mu / v$  (b)  $g / v$   
(c)  $v / g$  (d)  $v / (g\mu)$  [CBSE PMT 07]

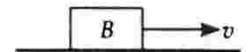

33. The coefficient of static friction,  $\mu_s$ , between block A of mass 2 kg and the table as shown in the figure is 0.2. What would be the maximum mass value

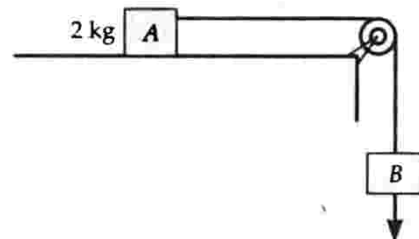

of block B so that the two blocks do not move ? The string and the pulley are assumed to be smooth and massless. ( $g = 10 \text{ m/s}^2$ )

- (a) 2.0 kg (b) 4.0 kg  
(c) 0.2 kg (d) 0.4 kg [CBSE PMT 04]

34. A block has been placed on an inclined plane with the slope angle  $\theta$ , block slides down the plane at constant speed. The coefficient of kinetic friction is equal to

- (a)  $\sin \theta$  (b)  $\cos \theta$   
(c)  $g$  (d)  $\tan \theta$  [CBSE PMT 93]

35. A mass  $M$  is placed on a very smooth wedge resting on a surface without friction. Once the mass is

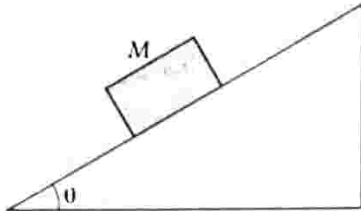

released, the acceleration to be given to the wedge so that  $M$  remains at rest is  $a$ , where

- (a)  $a$  is applied to the left and  $a = g \tan \theta$   
(b)  $a$  is applied to the right and  $a = g \tan \theta$   
(c)  $a$  is applied to the left and  $a = g \sin \theta$   
(d)  $a$  is applied to the left and  $a = g \cos \theta$ . [CBSE PMT 98]

36. A block of mass  $m$  is placed on a smooth wedge of inclination  $\theta$ . The whole system is accelerated horizontally so that the block does not slip on the wedge. The force exerted by the wedge on the block ( $g$  is acceleration due to gravity) will be

- (a)  $mg \cos \theta$  (b)  $mg \sin \theta$   
(c)  $mg$  (d)  $mg / \cos \theta$  [CBSE PMT 04]

37. Starting from rest, a body slides down a  $45^\circ$  inclined plane in twice the time it takes to slide down the same distance in the absence of friction. The coefficient of friction between the body and the inclined plane is

- (a) 0.80 (b) 0.75  
(c) 0.25 (d) 0.33 [CBSE PMT 88]

38. When milk is churned, cream gets separated due to

- (a) centripetal force (b) centrifugal force  
(c) frictional force (d) gravitational force [CBSE PMT 04]

39. A 500 kg car takes a round turn of radius 50 m with a velocity of 36 km/hr. The centripetal force is

- (a) 1000 N (b) 750 N  
(c) 250 N (d) 1200 N m/s [CBSE PMT 99]

40. A ball of mass 0.25 kg attached to the end of a string of length 1.96 m is moving in a horizontal circle. The string will break if the tension is more than 25 N.

What is the maximum speed with which the ball can be moved ?

- (a) 5 m/s (b) 3 m/s  
(c) 14 m/s (d) 3.92 m/s [CBSE PMT 98]

41. A tube of length  $L$  is filled completely with an incompressible liquid of mass  $M$  and closed at both the ends. The tube is then rotated in a horizontal plane about one of its ends with a uniform angular velocity  $\omega$ . The force exerted by the liquid at the other end is

- (a)  $\frac{ML^2\omega^2}{2}$  (b)  $\frac{ML\omega^2}{2}$   
(c)  $\frac{ML^2\omega}{2}$  (d)  $ML\omega^2$ . [CBSE PMT 06]

42. As shown in the figure at point  $O$ , a mass  $m$  is performing vertical circular motion. The average velocity of the particle is increased. Then at which point will the string break ?

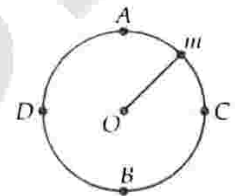

- (a) A (b) B  
(c) C (d) D [CBSE PMT 2K]

43. An explosion blows a rock into three parts. Two parts go off at right angles to each other. These two are, 1 kg first part moving with a velocity of  $12 \text{ ms}^{-1}$  and 2 kg second part moving with a velocity of  $8 \text{ ms}^{-1}$ . If the third part flies off with a velocity of  $4 \text{ ms}^{-1}$ , its mass would be

- (a) 3 kg (b) 5 kg  
(c) 7 kg (d) 17 kg. [CBSE PMT 09]

44. The mass of a lift is 2000 kg. When the tension in the cable is 28000 N, then its acceleration is

- (a)  $14 \text{ ms}^{-2}$  upwards  
(b)  $30 \text{ ms}^{-2}$  downwards  
(c)  $4 \text{ ms}^{-2}$  upwards  
(d)  $4 \text{ ms}^{-2}$  downwards. [CBSE PMT 09]

45. A mass  $m$  moving horizontally (along the  $x$ -axis) with velocity  $v$  collides and sticks to a mass of  $3m$  moving vertically upward (along the  $y$ -axis) with velocity  $2v$ .

The final velocity of the combination is

- (a)  $\frac{2}{3}v\hat{i} + \frac{1}{3}v\hat{j}$  (b)  $\frac{3}{2}v\hat{i} + \frac{1}{4}v\hat{j}$   
(c)  $\frac{1}{4}v\hat{i} + \frac{3}{2}v\hat{j}$  (d)  $\frac{1}{3}v\hat{i} + \frac{2}{3}v\hat{j}$

[CBSE Final 2011]

46. A body of mass  $M$  hits normally a rigid wall with velocity  $V$  and bounces back with the same velocity. The impulse experienced by the body is

- (a)  $MV$  (b)  $1.5 MV$   
(c)  $2 MV$  (d) zero [CBSE Pre 2011]

47. A man of 50 kg mass is standing in a gravity free space at a height of 10 m above the floor. He throws a stone of 0.5 kg mass downwards with a speed 2 m/s. When the stone reaches the floor, the distance of the man above the floor will be

- (a) 9.9 m (b) 10.1 m  
(c) 10 m (d) 20 m [CBSE Pre 2010]

48. A person of mass 60 kg is inside a lift of mass 940 kg and presses the button on control panel. The lift starts moving upwards with an acceleration  $1.0 \text{ m/s}^2$ . If  $g = 10 \text{ ms}^{-2}$ , the tension in the supporting cable is

- (a) 8600 N (b) 9680 N  
(c) 11000 N (d) 1200 N [CBSE Pre 2011]

49. A conveyor belt is moving at a constant speed of 2 m/s. A box is gently dropped on it. The coefficient of friction between them is  $\mu = 0.5$ . The distance that the box will move relative to belt before coming to rest on it, taking  $g = 10 \text{ ms}^{-2}$  is

- (a) zero (b) 0.4 m  
(c) 1.2 m (d) 0.6 m [CBSE Final 2011]

50. A block of mass  $m$  is in contact with the cart C as shown in the figure.

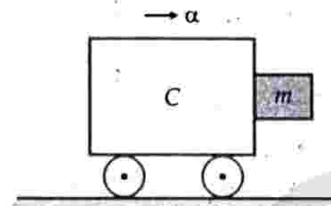

The coefficient of static friction between the block and the cart is  $\mu$ . The acceleration  $\alpha$  of the cart that will prevent the block from falling satisfies

- (a)  $\alpha > \frac{mg}{\mu}$  (b)  $\alpha > \frac{g}{\mu m}$   
(c)  $\alpha \geq \frac{g}{\mu}$  (d)  $\alpha < \frac{g}{\mu}$  [CBSE Pre 2010]

51. A gramophone record is revolving with an angular velocity  $\omega$ . A coin is placed at a distance  $r$  from the centre of the record. The static coefficient of friction is  $\mu$ . The coin will revolve with the record if

- (a)  $r = \mu g \omega^2$  (b)  $r < \frac{\omega^2}{\mu g}$   
(c)  $r \leq \frac{\mu g}{\omega^2}$  (d)  $r \geq \frac{\mu g}{\omega^2}$  [CBSE Pre 2010]

## Answers and Explanations

1. (c)  $m = \frac{F}{a} = \frac{10\text{N}}{1\text{ms}^{-2}} = 10 \text{ kg}$ .

2. (b)  $F = m \left( \frac{v-u}{t} \right) = \frac{150}{1000} \left( \frac{0-20}{0.1} \right) = -30 \text{ N}$ .

Force experienced by the cricketer = 30 N.

3. (b)  $a = \frac{F}{m} = \frac{6\text{N}}{1\text{kg}} = 6 \text{ ms}^{-2}$   
 $t = \frac{v-u}{a} = \frac{30-0}{6} = 5 \text{ s}$ .

4. (c) Newton's first law of motion is related to the physical independence of force.

5. (c)  $\vec{F} = 6\hat{i} - 8\hat{j} + 10\hat{k}$

$F = |\vec{F}| = \sqrt{36 + 64 + 100} = 10\sqrt{2} \text{ N}$

$m = \frac{F}{a} = \frac{10\sqrt{2}}{1\text{ms}^{-2}} = 10\sqrt{2} \text{ kg}$ .

6. (a) As no external force acts on the ball, it will continue to move with the same speed along the original orbit of the spacecraft.

7. (b)  $\vec{a} = \frac{\vec{F}}{m} = \frac{1}{3}(6t^2\hat{i} + 4t\hat{j}) = \frac{d\vec{v}}{dt}$   
 $d\vec{v} = \frac{1}{3}(6t^2\hat{i} + 4t\hat{j})dt$

Velocity at  $t = 3 \text{ s}$  will be

$\vec{v} = \int d\vec{v} = \frac{1}{3} \int_0^3 (6t^2\hat{i} + 4t\hat{j}) dt$   
 $= \frac{1}{3} \left[ 2t^3\hat{i} + 2t^2\hat{j} \right]_0^3 = \frac{2}{3} (3^3\hat{i} + 3^2\hat{j})$   
 $= (18\hat{i} + 6\hat{j}) \text{ ms}^{-1}$ .

8. (a)  $F = \frac{dp}{dt} = \frac{d}{dt}(mv) = v \frac{dm}{dt}$   
 $= v \times M = Mv \text{ newton}$ .



9. (a) The resultant force will be along  $y$ -direction if the resultant of the components along  $x$ -direction is zero. If  $F$  is the force needed along  $OX$ , then

$$F + 1 \cos 60^\circ + 2 \cos 60^\circ = 4 \cos 60^\circ$$

or  $F = (4 - 1 - 2) \cos 60^\circ$

$$= \frac{1}{2} = 0.5 \text{ N.}$$

10. (c) When the particle lands on the level ground, its momentum along horizontal direction does not change.

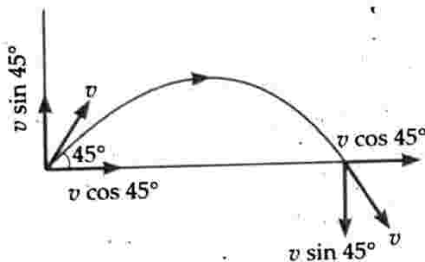

But vertical component of velocity gets reversed.

Change in momentum in vertical direction

$$= mv \sin 45^\circ - (-mv \sin 45^\circ)$$

$$= 2mv \times \frac{1}{\sqrt{2}} = \sqrt{2} mv.$$

11. (d) Impulse = Change in momentum =  $m(v_2 - v_1)$ .

12. (d) When the force on the bullet becomes zero,

$$600 - 2 \times 10^5 t = 0$$

or  $t = 3 \times 10^{-3} \text{ s}$

Impulse,  $J = \int_0^t F dt$

$$= \int_0^t (600 - 2 \times 10^5 t) dt = 600t - 2 \times 10^5 \frac{t^2}{2}$$

$$= 600 \times 3 \times 10^{-3} - 10^5 \times (3 \times 10^{-3})^2$$

$$= 1.8 - 0.9 = 0.9 \text{ Ns.}$$

13. (a) Change in momentum along vertical direction

$$= p \sin 30^\circ - p \sin 30^\circ = 0$$

Change in momentum along horizontal direction

$$= -p \cos 30^\circ - p \cos 30^\circ$$

$$= -2p \cos 30^\circ = -2mv \cos 30^\circ$$

$$= -2 \times 3 \times 10 \times \frac{\sqrt{3}}{2} = -30\sqrt{3} \text{ kg ms}^{-1}$$

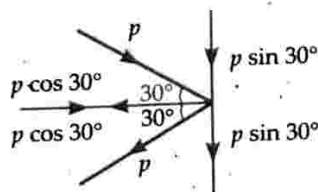

Force exerted on the wall

$$= \frac{\text{Change in momentum}}{\text{Time of impact}}$$

$$= \frac{30\sqrt{3}}{0.2} = 150\sqrt{3} \text{ N.}$$

14. (c) Proceeding as in the above problem,

$$F = \frac{2mv \cos(90^\circ - 30^\circ)}{t}$$

$$= \frac{2 \times 0.5 \times 12 \times \cos 60^\circ}{t} = 24 \text{ N.}$$

15. (b) For the lift moving upward with acceleration  $a$ ,

$$T = m(g + a) = 1000(9.8 + 1) \text{ N} = 10800 \text{ N.}$$

16. (c) For upward acceleration,

$$T_1 = m(g + a)$$

For downward acceleration,

$$T_2 = m(g - a)$$

$$\frac{T_1}{T_2} = \frac{g + a}{g - a} = \frac{9.8 + 4.9}{9.8 - 4.9} = \frac{14.7}{4.9} = 3 : 1.$$

17. (d) As the lift accelerates upward, the apparent weight,

$$R = m(g + a) = 80(10 + 5) = 1200 \text{ N.}$$

18. (d) When the monkey climbs the rope with acceleration  $a$ ,

$$T = m(g + a)$$

or  $Mg = mg + ma$

$$25 \times 10 = 20 \times 10 + 20a$$

or  $a = \frac{50}{20} = 2.5 \text{ m/s}^2$ .

19. (c) When the monkey descends with acceleration  $a$ ,

$$T = m(g - a)$$

$$\frac{75}{100} mg = m(g - a)$$

or  $a = g - \frac{3}{4}g = \frac{g}{4}$ .

$$20. (b) a = \frac{(m_1 - m_2)g}{m_1 + m_2} = \frac{(10 - 5) \times g}{(10 + 5)} = \frac{g}{3}$$

21. (a) By conservation of momentum,

$$mv + MV = 0$$

$$\frac{200}{1000} \times 5 + 1 \times V = 0$$

or  $V = 1 \text{ m/s.}$

22. (a) Refer to the solution of Example 23 on page 5.22.

23. (a) Clearly,  $m_1 = 1 \text{ kg}$ ,  $m_2 = 1 \text{ kg}$ ,  $m_3 = 3 \text{ kg}$ .

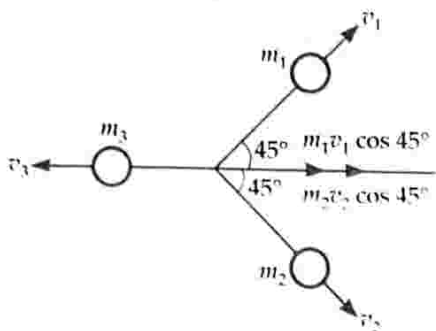

By conservation of momentum along horizontal direction,

$$m_3 v_3 = m_1 v_1 \cos 45^\circ + m_2 v_2 \cos 45^\circ$$

$$3v_3 = 1 \times 21 \times \frac{1}{\sqrt{2}} + 1 \times 21 \times \frac{1}{\sqrt{2}}$$

$$v_3 = \frac{7}{\sqrt{2}} + \frac{7}{\sqrt{2}} = 7\sqrt{2} \text{ ms}^{-1}$$

24. (b)  $F = u \frac{dm}{dt} = 60 \text{ kms}^{-1} \times 1 \text{ kg s}^{-1}$   
 $= 60000 \text{ kg ms}^{-2}$   
 $= 60000 \text{ N}$ .

25. (c)  $F = u \frac{dm}{dt}$   
 $210 = 300 \times \frac{dm}{dt}$   
 $\frac{dm}{dt} = \frac{210}{300} = 0.7 \text{ kg s}^{-1}$ .

26. (c) Thrust needed to overcome the weight of the rocket,

$$F = mg = u \frac{dm}{dt}$$

$$\therefore \frac{dm}{dt} = \frac{mg}{u} = \frac{600 \times 10}{1000} = 6 \text{ kg s}^{-1}$$

27. (b) Initial acceleration,

$$a = \frac{u}{m_0} \frac{dm}{dt} - g$$

$$20 = \frac{800}{5000} \times \frac{dm}{dt} - 10$$

$$\frac{dm}{dt} = \frac{30 \times 50}{8} = 187.5 \text{ kg s}^{-1}$$

28. (b) Net force = Applied force - Force of friction

$$F = 100 - \mu mg$$

$$= 100 - 0.5 \times 10 \times 10 = 50 \text{ N}$$

$$a = \frac{F}{m} = \frac{50}{10} = 5 \text{ ms}^{-2}$$

29. (a) As the block is in the accelerated frame, it experiences a backward force,

$$F = ma = 1 \times 5 = 5 \text{ N}$$

Limiting friction,

$$f_s^{\max} = \mu mg = 0.6 \times 1 \times 10 = 6 \text{ N}$$

As  $F < f_s^{\max}$ ,

the block does not move.

Static friction = Backward force = 5 N.

30. (b) Retardation,

$$a = -\mu g = -0.5 \times 10 = -5 \text{ ms}^{-2}$$

$$u = 72 \text{ km/h} = 20 \text{ ms}^{-1}$$

As  $v^2 - u^2 = 2as$

$$\therefore 0^2 - 20^2 = 2(-5)s$$

or  $s = 40 \text{ m}$ .

31. (a) Suppose length  $x$  of the chain hangs over one edge of the table.

Mass per unit length of the chain =  $\frac{M}{L}$

Weight of the hanging part,  $W = \frac{M}{L} xg$

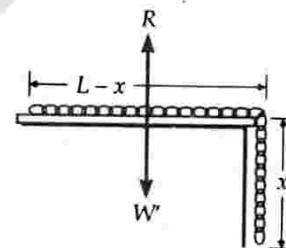

Weight of the hanging part applies force on the remaining part of the chain. The chain will not slide further if the limiting friction balances the weight  $W$ .

$$\therefore f_s^{\max} = W = \frac{M}{L} xg$$

Normal reaction

= Weight of length  $(L-x)$  of the chain

$$R = W' = \frac{M}{L} (L-x)g$$

Now  $f_s^{\max} = \mu R$

$$\text{or } \frac{M}{L} xg = \mu \frac{M}{L} (L-x)g$$

$$\text{or } x = \mu(L-x) \quad \text{or } x = \frac{\mu L}{1+\mu}$$

Given  $\mu = 0.25$

$$\therefore \frac{x}{L} \times 100 = \frac{0.25}{1+0.25} \times 100 = 20\%$$

32. (d) Retardation,  $a = -\mu g$

As  $v = u + at$

$$0 = v - \mu g t \quad \text{or } t = \frac{v}{\mu g}$$

33. (d) For the equilibrium of block A, the force of friction must balance the tension in the string.

$$\therefore \mu m_A g = T$$

For the equilibrium of block B, the tension in the string must be equal to its weight

$$\therefore m_B g = T$$

$$\text{Hence } m_B g = \mu m_A g$$

$$\text{or } m_B = \mu m_A = 0.2 \times 2 \\ = 0.4 \text{ kg.}$$

34. (v) As the block slides down the inclined plane with a constant speed, the angle of inclination is equal to the angle of repose.

$$\therefore \mu = \text{tangent of the angle of repose}$$

$$\text{or } \mu = \tan \theta$$

35. (a) When the wedge is given an acceleration  $a$  towards left, the block receives a reaction  $ma$  towards right.

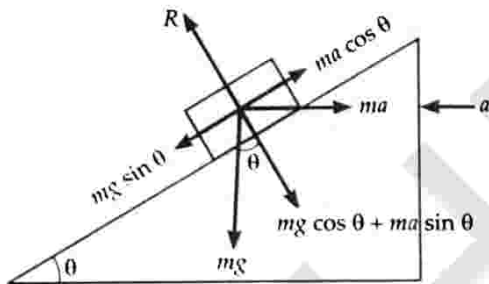

For the block to remain at rest,

$$ma \cos \theta = mg \sin \theta$$

$$\text{or } a = g \tan \theta$$

36. (d) Refer to the figure of the above problem.

$$ma \cos \theta = mg \sin \theta$$

$$a = g \tan \theta$$

Total reaction of the wedge on the block is

$$R = mg \cos \theta + ma \sin \theta \\ = mg \cos \theta + m \cdot \frac{g \sin \theta}{\cos \theta} \cdot \sin \theta \\ = \frac{mg(\cos^2 \theta + \sin^2 \theta)}{\cos \theta} = \frac{mg}{\cos \theta}$$

37. (b) Refer to the solution of Problem 16 on page 5.74.

$$\mu = 1 - \frac{1}{n^2}$$

In the given problem,  $n = 2$

$$\therefore \mu = 1 - \frac{1}{2^2} = \frac{3}{4} = 0.75.$$

38. (b) When milk is churned, cream gets separated due to centrifugal force.

$$39. (a) \quad v = 36 \text{ km h}^{-1} = 36 \times \frac{5}{18} \text{ ms}^{-1} = 10 \text{ ms}^{-1}$$

$$F = \frac{mv^2}{r} \\ = \frac{500 \times 10 \times 10}{50} = 1000 \text{ N.}$$

$$40. (c) \quad T = \frac{mv_{\max}^2}{r}$$

$$v_{\max} = \sqrt{\frac{Tr}{m}} = \sqrt{\frac{25 \times 1.96}{0.25}} = 14 \text{ ms}^{-1}.$$

41. (b) The mass of the liquid acts at the centre of the tube.

$$\text{Therefore, } r = \frac{L}{2}.$$

Force exerted by the liquid at the other end  
= Centrifugal force

$$= Mr\omega^2 = M\left(\frac{L}{2}\right)\omega^2 = \frac{ML\omega^2}{2}.$$

42. (b) The tension in the string will be maximum when the particle is at the lowest point B

$$T_B = \text{Weight of particle} + \frac{mv^2}{R}$$

Hence the string will break at point B when the average velocity  $v$  is increased.

$$43. (b) \quad \vec{p}_1 + \vec{p}_2 + \vec{p}_3 = \vec{0} \quad \text{or} \quad \vec{p}_3 = -(\vec{p}_1 + \vec{p}_2)$$

$$\therefore m_3 v_3 = \sqrt{p_1^2 + p_2^2} \quad [\because \vec{p}_1 \perp \vec{p}_2]$$

$$\text{or } m_3 = \frac{\sqrt{(1 \times 12)^2 + (2 \times 8)^2}}{4} \\ = 5 \text{ kg.}$$

$$44. (c) \quad T = m(g + a)$$

$$\text{or } a = \frac{T - mg}{m} = \frac{28000 - 20000}{2000} \\ = 4 \text{ ms}^{-2}, \text{ upwards.}$$

45. (c) For conservation of momentum along x-axis,

$$mv + 0 = 4mv'_x \Rightarrow v'_x = \frac{v}{4}$$

For conservation of momentum along y-axis,

$$3m \times 2v = 4mv'_y \Rightarrow v'_y = \frac{3}{2}v$$

$$\therefore v' = \frac{v}{4} \hat{i} + \frac{3}{2}v \hat{j}$$

**5.126 PHYSICS-XI**

46. (c) | Impulse | =  $MV - (-MV) = 2MV$

47. (b) By conservation of momentum,

$$50u + 0.5 \times 2 = 0$$

$$u = -\frac{1}{50} \text{ms}^{-1} \left[ \frac{1}{50} \text{ms}^{-1} \text{ upward} \right]$$

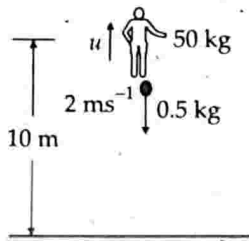

Time taken by stone to reach the ground =  $\frac{10}{2} = 5 \text{ s}$

Distance moved up by the man

$$= 5 \times \frac{1}{50} = 0.1 \text{ m}$$

When the stone reaches the floor, the distance of the man above floor

$$= 10 + 0.1 = 10.1 \text{ m}$$

48. (c)  $T - mg = ma$

$$T = m(g + a)$$

$$= (940 + 60) \times (10 + 1)$$

$$= 11000 \text{ N}$$

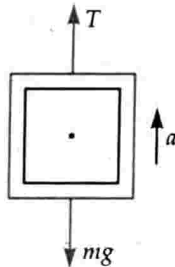

49. (b)  $u = 2 \text{ m/s}, \mu = 0.5, g = 10 \text{ ms}^{-2}$

$$a = \frac{F}{m} = \frac{\mu mg}{m}$$

$$= 0.5 \times 10 = 5 \text{ m/s}^2$$

Retardation,  $a = -5 \text{ m/s}^2$

$$v^2 - u^2 = 2as$$

$$\therefore 0^2 - 2^2 = 2(-5) \times s$$

or

$$s = 0.4 \text{ m}$$

50. (c) Force of friction,

$$f = \mu N = \mu m \alpha$$

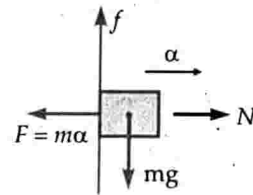

To prevent the block from falling,

$$\mu m \alpha \geq mg$$

or

$$\alpha \geq \frac{m}{g}$$

51. (c) The coin will revolve with the record if

Centripetal force  $\leq$  Force of friction

$$m r \omega^2 \leq \mu m g$$

$$r \leq \frac{\mu g}{\omega^2}$$